

TOPOLOGY WITHOUT TEARS¹

SIDNEY A. MORRIS

Version of March 8, 2004²

¹©Copyright 1985-2004. No part of this book may be reproduced by any process without prior written permission from the author. If you would like a printable version of this book please e-mail your name, address, and commitment to respect the copyright (by not providing the password, hard copy or soft copy to anyone else) to s.morris@ballarat.edu.au

²This book is being progressively updated and expanded; it is anticipated that there will be about fifteen chapters in all. Only those chapters which appear in colour have been updated so far. If you discover any errors or you have suggested improvements please e-mail: s.morris@ballarat.edu.au

Contents

Title Page and Copyright Statement	1
Contents	2
Introduction	4
Acknowledgment	5
Readers – Locations and Professions	5
Readers' Compliments	6
1 Topological Spaces	7
1.1 Topology	8
1.2 Open Sets	15
1.3 Finite-Closed Topology	20
1.4 Postscript	27
2 The Euclidean Topology	29
2.1 Euclidean Topology	30
2.2 Basis for a Topology	35
2.3 Basis for a Given Topology	42
2.4 Postscript	49
3 Limit Points	50
3.1 Limit Points and Closure	51
3.2 Neighbourhoods	56
3.3 Connectedness	60
3.4 Postscript	63
4 Homeomorphisms	64
4.1 Subspaces	64
4.2 Homeomorphisms	69

<i>CONTENTS</i>	3
4.3 Non-Homeomorphic Spaces	75
4.4 Postscript	83
5 Continuous Mappings	84
5.1 Continuous Mappings	84
5.2 Intermediate Value Theorem	91
5.3 Postscript	97
6 Metric Spaces	98
6.1 Metric Spaces	98
6.2 Convergence of Sequences	115
6.3 Completeness	119
6.4 Contraction Mappings	130
6.5 Baire Spaces	133
6.6 Postscript	139
7 Compactness	141
7.1 Compact Spaces	142
7.2 The Heine-Borel Theorem	146
7.3 Postscript	153
8 Finite Products	154
8.1 The Product Topology	155
8.2 Projections onto Factors of a Product	159
8.3 Tychonoff's Theorem for Finite Products	164
8.4 Products and Connectedness	167
8.5 Fundamental Theorem of Algebra	171
8.6 Postscript	173
Appendix 1: Infinite Sets	174
Bibliography	197
Index	211

Introduction

Topology is an important and interesting area of mathematics, the study of which will not only introduce you to new concepts and theorems but also put into context old ones like continuous functions. However, to say just this is to understate the significance of topology. It is so fundamental that its influence is evident in almost every other branch of mathematics. This makes the study of topology relevant to all who aspire to be mathematicians whether their first love is (or will be) algebra, analysis, category theory, chaos, continuum mechanics, dynamics, geometry, industrial mathematics, mathematical biology, mathematical economics, mathematical finance, mathematical modelling, mathematical physics, mathematics of communication, number theory, numerical mathematics, operations research or statistics. (The substantial bibliography at the end of this book suffices to indicate that topology does indeed have relevance to all these areas, and more.) Topological notions like compactness, connectedness and denseness are as basic to mathematicians of today as sets and functions were to those of last century.

Topology has several different branches — general topology (also known as point-set topology), algebraic topology, differential topology and topological algebra — the first, general topology, being the door to the study of the others. We aim in this book to provide a thorough grounding in general topology. Anyone who conscientiously studies about the first ten chapters and solves at least half of the exercises will certainly have such a grounding.

For the reader who has not previously studied an axiomatic branch of mathematics such as abstract algebra, learning to write proofs will be a hurdle. To assist you to learn how to write proofs, quite often in the early chapters, we include an **aside** which does not form part of the proof but outlines the thought process which led to the proof.

Asides are indicated in the following manner:

In order to arrive at the proof, we went through this thought process, which might well be called the “discovery” or “experiment phase”.

However, the reader will learn that while discovery or experimentation is often essential, nothing can replace a formal proof.

There are many exercises in this book. Only by working through a good number of exercises will you master this course. Very often we include new concepts in the exercises; the concepts which we consider most important will generally be introduced again in the text.

Harder exercises are indicated by an *.

Acknowledgment

Portions of earlier versions of this book were used at La Trobe University, University of New England, University of Wollongong, University of Queensland, University of South Australia and City College of New York over the last 25 years. I wish to thank those students who criticized the earlier versions and identified errors. Special thanks go to Deborah King and Allison Plant for pointing out numerous errors and weaknesses in the presentation. Thanks also go to several other colleagues including Carolyn McPhail, Ralph Kopperman, Karl Heinrich Hofmann, Rodney Nillsen, Peter Pleasants, Geoffrey Prince, Bevan Thompson and Ewan Barker who read earlier versions and offered suggestions for improvements. Thanks also go to Jack Gray whose excellent University of New South Wales Lecture Notes “Set Theory and Transfinite Arithmetic”, written in the 1970s, influenced our Appendix on Infinite Set Theory.

Readers – Locations and Professions

This book has been used by actuaries, chemists, computer scientists, economists, aeronautical, mechanical, electrical and telecommunications engineers, mathematicians, philosophers, physicists, psychologists, and statisticians in Argentina, Australia, Belgium, Brazil, Bulgaria, Canada, Chile, China, Colombia, Costa Rica, Czech Republic, Egypt, Estonia, Finland, France, Gaza, Germany, Ghana, India, Iran, Israel, Italy, Kuwait, Luxembourg, Malta, Mexico, Netherlands, Nicaragua,

Nigeria, Pakistan, Peru, Poland, Portugal, Romania, Russia, Serbia, Singapore, Slovenia, Sweden, Taiwan, Thailand, Turkey, United Kingdom, Ukraine, Uruguay, Venezuela, and USA.

Readers' Compliments

T. Lessley, USA: "delightful work, beautifully written";

E. Ferrer, Australia: "your notes are fantastic";

E. Yuan, Germany: "it is really a fantastic book for beginners in Topology";

S. Kumar, India: "very much impressed with the easy treatment of the subject, which can be easily followed by nonmathematicians";

Pawin Siriprapanukul, Thailand: "I am preparing myself for a Ph.D. (in economics) study and find your book really helpful to the complex subject of topology";

Hannes Reijner, Sweden: "think it's excellent";

G. Gray, USA: "wonderful text";

Dipak Banik, India: "beautiful note";

B. Pragoff Jr, USA: "explains topology to an undergrad very well";

Tapas Kumar Bose, India: "an excellent collection of information";

Gabriele Luculli, Italy: "I'm just a young student, but I found very interesting the way you propose the topology subject, especially the presence of so many examples";

K. Orr, USA: "excellent book";

Professor Ahmed Ould, Colombia: "let me congratulate you for presentation, simplicity and the clearness of the material";

Paul Unstead, USA: "I like your notes since they provide many concrete examples and do not assume that the reader is a math major";

Alberto Garca Raboso, Spain: "I like it very much";

Guiseppe Curci, Research Director in Theoretical Physics, National Institute of Theoretical Physics, Pisa: "nice and illuminating book on topology";

M. Rinaldi, USA: "this is by far the clearest and best introduction to topology I have ever seen ... when I studied your notes the concepts clicked and your examples are great";

Degin Cai, USA: "your book is wonderful";

M.A.R. Khan, Karachi: "thank you for remembering a third world student".

©Copyright 1985-2004. No part of this book may be reproduced by any process without prior written permission from the author.

Chapter 1

Topological Spaces

Introduction

Tennis, football, baseball and hockey may all be exciting games but to play them you must first learn (some of) the rules of the game. Mathematics is no different. So we begin with the rules for topology.

This chapter opens with the definition of a topology and is then devoted to some simple examples: finite topological spaces, discrete spaces, indiscrete spaces, and spaces with the finite-closed topology.

Topology, like other branches of pure mathematics such as group theory, is an axiomatic subject. We start with a set of axioms and we use these axioms to prove propositions and theorems. It is extremely important to develop your skill at writing proofs.

Why are proofs so important? Suppose our task were to construct a building. We would start with the foundations. In our case these are the axioms or definitions – everything else is built upon them. Each theorem or proposition represents a new level of knowledge and must be firmly anchored to the previous level. We attach the new level to the previous one using a proof. So the theorems and propositions are the new heights of knowledge we achieve, while the proofs are essential as they are the mortar which attaches them to the level below. Without proofs the structure would collapse.

So what is a mathematical proof?

A **mathematical proof** is a watertight argument which begins with information you are given, proceeds by logical argument, and ends with what you are asked to prove.

You should begin a proof by writing down the information you are given and then state what you are asked to prove. If the information you are given or what you are required to prove contains technical terms, then you should write down the definitions of those technical terms.

Every proof should consist of complete sentences. Each of these sentences should be a consequence of (i) what has been stated previously or (ii) a theorem, proposition or lemma that has already been proved.

In this book you will see many proofs, but note that mathematics is not a spectator sport. It is a game for participants. The only way to learn to write proofs is to try to write them yourself.

1.1 Topology

1.1.1 Definitions. Let X be a non-empty set. A collection \mathcal{T} of subsets of X is said to be a **topology** on X if

- (i) X and the empty set, \emptyset , belong to \mathcal{T} ,
- (ii) the union of any (finite or infinite) number of sets in \mathcal{T} belongs to \mathcal{T} , and
- (iii) the intersection of any two sets in \mathcal{T} belongs to \mathcal{T} .

The pair (X, \mathcal{T}) is called a **topological space**.

1.1.2 Example. Let $X = \{a, b, c, d, e, f\}$ and

$$\mathcal{T}_1 = \{X, \emptyset, \{a\}, \{c, d\}, \{a, c, d\}, \{b, c, d, e, f\}\}.$$

Then \mathcal{T}_1 is a topology on X as it satisfies conditions (i), (ii) and (iii) of Definitions 1.1.1. \square

1.1.3 Example. Let $X = \{a, b, c, d, e\}$ and

$$\mathcal{T}_2 = \{X, \emptyset, \{a\}, \{c, d\}, \{a, c, e\}, \{b, c, d\}\}.$$

Then \mathcal{T}_2 is **not** a topology on X as the union

$$\{c, d\} \cup \{a, c, e\} = \{a, c, d, e\}$$

of two members of \mathcal{T}_2 does not belong to \mathcal{T}_2 ; that is, \mathcal{T}_2 does not satisfy condition (ii) of Definitions 1.1.1. \square

1.1.4 Example. Let $X = \{a, b, c, d, e, f\}$ and

$$\mathcal{T}_3 = \{X, \emptyset, \{a\}, \{f\}, \{a, f\}, \{a, c, f\}, \{b, c, d, e, f\}\}.$$

Then \mathcal{T}_3 is not a topology on X since the intersection

$$\{a, c, f\} \cap \{b, c, d, e, f\} = \{c, f\}$$

of two sets in \mathcal{T}_3 does not belong to \mathcal{T}_3 ; that is, \mathcal{T}_3 does not have property (iii) of Definitions 1.1.1. □

1.1.5 Example. Let \mathbb{N} be the set of all natural numbers (that is, the set of all positive integers) and let \mathcal{T}_4 consist of \mathbb{N} , \emptyset , and all finite subsets of \mathbb{N} . Then \mathcal{T}_4 is not a topology on \mathbb{N} , since the infinite union

$$\{2\} \cup \{3\} \cup \dots \cup \{n\} \cup \dots = \{2, 3, \dots, n, \dots\}$$

of members of \mathcal{T}_4 does not belong to \mathcal{T}_4 ; that is, \mathcal{T}_4 does not have property (ii) of Definitions 1.1.1. □

1.1.6 Definitions. Let X be any non-empty set and let \mathcal{T} be the collection of all subsets of X . Then \mathcal{T} is called the **discrete topology** on the set X . The topological space (X, \mathcal{T}) is called a **discrete space**.

We note that \mathcal{T} in Definitions 1.1.6 does satisfy the conditions of Definitions 1.1.1 and so is indeed a topology.

Observe that the set X in Definitions 1.1.6 can be any non-empty set. So there is an infinite number of discrete spaces – one for each set X .

1.1.7 Definitions. Let X be any non-empty set and $\mathcal{T} = \{X, \emptyset\}$. Then \mathcal{T} is called the **indiscrete topology** and (X, \mathcal{T}) is said to be an **indiscrete space**.

Once again we have to check that \mathcal{T} satisfies the conditions of Definitions 1.1.1 and so is indeed a topology.

We observe again that the set X in Definitions 1.1.7 can be any non-empty set. So there is an infinite number of indiscrete spaces – one for each set X .

In the introduction to this chapter we discussed the importance of proofs and what is involved in writing them. Our first experience with proofs is in Example 1.1.8 and Proposition 1.1.9. You should study these proofs carefully.

1.1.8 Example. If $X = \{a, b, c\}$ and \mathcal{T} is a topology on X with $\{a\} \in \mathcal{T}$, $\{b\} \in \mathcal{T}$, and $\{c\} \in \mathcal{T}$, prove that \mathcal{T} is the discrete topology.

Proof.

We are given that \mathcal{T} is a topology and that $\{a\} \in \mathcal{T}$, $\{b\} \in \mathcal{T}$, and $\{c\} \in \mathcal{T}$.

We are required to prove that \mathcal{T} is the discrete topology; that is, we are required to prove (by Definitions 1.1.6) that \mathcal{T} contains all subsets of X . Remember that \mathcal{T} is a topology and so satisfies conditions (i), (ii) and (iii) of Definitions 1.1.1.

So we shall begin our proof by writing down all of the subsets of X .

The set X has 3 elements and so it has 2^3 distinct subsets. They are: $S_1 = \emptyset$, $S_2 = \{a\}$, $S_3 = \{b\}$, $S_4 = \{c\}$, $S_5 = \{a, b\}$, $S_6 = \{a, c\}$, $S_7 = \{b, c\}$, and $S_8 = \{a, b, c\} = X$.

We are required to prove that each of these subsets is in \mathcal{T} . As \mathcal{T} is a topology, Definitions 1.1.1 (i) implies that X and \emptyset are in \mathcal{T} ; that is, $S_1 \in \mathcal{T}$ and $S_8 \in \mathcal{T}$.

We are given that $\{a\} \in \mathcal{T}$, $\{b\} \in \mathcal{T}$ and $\{c\} \in \mathcal{T}$; that is, $S_2 \in \mathcal{T}$, $S_3 \in \mathcal{T}$ and $S_4 \in \mathcal{T}$.

To complete the proof we need to show that $S_5 \in \mathcal{T}$, $S_6 \in \mathcal{T}$, and $S_7 \in \mathcal{T}$. But $S_5 = \{a, b\} = \{a\} \cup \{b\}$. As we are given that $\{a\}$ and $\{b\}$ are in \mathcal{T} , Definitions 1.1.1 (ii) implies that their union is also in \mathcal{T} ; that is, $S_5 = \{a, b\} \in \mathcal{T}$.

Similarly $S_6 = \{a, c\} = \{a\} \cup \{c\} \in \mathcal{T}$ and $S_7 = \{b, c\} = \{b\} \cup \{c\} \in \mathcal{T}$. □

In the introductory comments on this chapter we observed that mathematics is not a spectator sport. You should be an active participant. Of course your participation includes doing some of the exercises. But more than this is expected of you. You have to think about the material presented to you.

One of your tasks is to look at the results that we prove and to ask pertinent questions. For example, we have just shown that if each of the singleton sets $\{a\}$, $\{b\}$ and $\{c\}$ is in \mathcal{T} and $X = \{a, b, c\}$, then \mathcal{T} is the discrete topology. You should ask if this is but one example of a more general phenomenon; that is, if (X, \mathcal{T}) is any topological space such that \mathcal{T} contains every singleton set, is \mathcal{T} necessarily the discrete topology? The answer is “yes”, and this is proved in Proposition 1.1.9.

1.1.9 Proposition. If (X, \mathcal{T}) is a topological space such that, for every $x \in X$, the singleton set $\{x\}$ is in \mathcal{T} , then \mathcal{T} is the discrete topology.

Proof.

This result is a generalization of Example 1.1.8. Thus you might expect that the proof would be similar. However, we cannot list all of the subsets of X as we did in Example 1.1.8 because X may be an infinite set. Nevertheless we must prove that **every** subset of X is in \mathcal{T} .

At this point you may be tempted to prove the result for some special cases, for example taking X to consist of 4, 5 or even 100 elements. But this approach is doomed to failure. Recall our opening comments in this chapter where we described a mathematical proof as a watertight argument. We cannot produce a watertight argument by considering a few special cases, or even a very large number of special cases. The watertight argument must cover **all** cases. So we must consider the general case of an arbitrary non-empty set X . Somehow we must prove that every subset of X is in \mathcal{T} .

Looking again at the proof of Example 1.1.8 we see that the key is that every subset of X is a union of singleton subsets of X and we already know that all of the singleton subsets are in \mathcal{T} . This is also true in the general case.

We begin the proof by recording the fact that every set is a union of its singleton subsets. Let S be any subset of X . Then

$$S = \bigcup_{x \in S} \{x\}.$$

Since we are given that each $\{x\}$ is in \mathcal{T} , Definitions 1.1.1 (ii) and the above equation imply that $S \in \mathcal{T}$. As S is an arbitrary subset of X , we have that \mathcal{T} is the discrete topology. \square

That every set S is a union of its singleton subsets is a result which we shall use from time to time throughout the book in many different contexts. Note that it holds even when $S = \emptyset$ as then we form what is called an **empty union** and get \emptyset as the result.

Exercises 1.1

1. Let $X = \{a, b, c, d, e, f\}$. Determine whether or not each of the following collections of subsets of X is a topology on X :

(a) $\mathcal{T}_1 = \{X, \emptyset, \{a\}, \{a, f\}, \{b, f\}, \{a, b, f\}\};$

(b) $\mathcal{T}_2 = \{X, \emptyset, \{a, b, f\}, \{a, b, d\}, \{a, b, d, f\}\};$

(c) $\mathcal{T}_3 = \{X, \emptyset, \{f\}, \{e, f\}, \{a, f\}\}.$

2. Let $X = \{a, b, c, d, e, f\}$. Which of the following collections of subsets of X is a topology on X ? (Justify your answers.)

(a) $\mathcal{T}_1 = \{X, \emptyset, \{c\}, \{b, d, e\}, \{b, c, d, e\}, \{b\}\};$

(b) $\mathcal{T}_2 = \{X, \emptyset, \{a\}, \{b, d, e\}, \{a, b, d\}, \{a, b, d, e\}\};$

(c) $\mathcal{T}_3 = \{X, \emptyset, \{b\}, \{a, b, c\}, \{d, e, f\}, \{b, d, e, f\}\}.$

3. If $X = \{a, b, c, d, e, f\}$ and \mathcal{T} is the discrete topology on X , which of the following statements are true?

(a) $X \in \mathcal{T};$ (b) $\{X\} \in \mathcal{T};$ (c) $\{\emptyset\} \in \mathcal{T};$ (d) $\emptyset \in \mathcal{T};$

(e) $\emptyset \in X;$ (f) $\{\emptyset\} \in X;$ (g) $\{a\} \in \mathcal{T};$ (h) $a \in \mathcal{T};$

(i) $\emptyset \subseteq X;$ (j) $\{a\} \in X;$ (k) $\{\emptyset\} \subseteq X;$ (l) $a \in X;$

(m) $X \subseteq \mathcal{T};$ (n) $\{a\} \subseteq \mathcal{T};$ (o) $\{X\} \subseteq \mathcal{T};$ (p) $a \subseteq \mathcal{T}.$

[Hint. Precisely six of the above are true.]

4. Let (X, \mathcal{T}) be any topological space. Verify that **the intersection of any finite number of members of \mathcal{T} is a member of \mathcal{T} .**

[Hint. To prove this result use “mathematical induction”.]

5. Let \mathbb{R} be the set of all real numbers. Prove that each of the following collections of subsets of \mathbb{R} is a topology.
- (i) \mathcal{T}_1 consists of \mathbb{R} , \emptyset , and every interval $(-n, n)$, for n any positive integer;
 - (ii) \mathcal{T}_2 consists of \mathbb{R} , \emptyset , and every interval $[-n, n]$, for n any positive integer;
 - (iii) \mathcal{T}_3 consists of \mathbb{R} , \emptyset , and every interval $[n, \infty)$, for n any positive integer.
6. Let \mathbb{N} be the set of all positive integers. Prove that each of the following collections of subsets of \mathbb{N} is a topology.
- (i) \mathcal{T}_1 consists of \mathbb{N} , \emptyset , and every set $\{1, 2, \dots, n\}$, for n any positive integer. (This is called the **initial segment topology**.)
 - (ii) \mathcal{T}_2 consists of \mathbb{N} , \emptyset , and every set $\{n, n + 1, \dots\}$, for n any positive integer. (This is called the **final segment topology**.)
7. List all possible topologies on the following sets:
- (a) $X = \{a, b\}$;
 - (b) $Y = \{a, b, c\}$.
8. Let X be an infinite set and \mathcal{T} a topology on X . If every infinite subset of X is in \mathcal{T} , prove that \mathcal{T} is the discrete topology.
- 9.* Let \mathbb{R} be the set of all real numbers. Precisely three of the following ten collections of subsets of \mathbb{R} are topologies? Identify these and justify your answer.
- (i) \mathcal{T}_1 consists of \mathbb{R} , \emptyset , and every interval (a, b) , for a and b any real numbers with $a < b$;
 - (ii) \mathcal{T}_2 consists of \mathbb{R} , \emptyset , and every interval $(-r, r)$, for r any positive real number;
 - (iii) \mathcal{T}_3 consists of \mathbb{R} , \emptyset , and every interval $(-r, r)$, for r any positive rational number;
 - (iv) \mathcal{T}_4 consists of \mathbb{R} , \emptyset , and every interval $[-r, r]$, for r any positive rational number;
 - (v) \mathcal{T}_5 consists of \mathbb{R} , \emptyset , and every interval $(-r, r)$, for r any positive irrational number;
 - (vi) \mathcal{T}_6 consists of \mathbb{R} , \emptyset , and every interval $[-r, r]$, for r any positive irrational number;
 - (vii) \mathcal{T}_7 consists of \mathbb{R} , \emptyset , and every interval $[-r, r)$, for r any positive real number;
 - (viii) \mathcal{T}_8 consists of \mathbb{R} , \emptyset , and every interval $(-r, r]$, for r any positive real number;

- (ix) \mathcal{T}_9 consists of \mathbb{R} , \emptyset , every interval $[-r, r]$, and every interval $(-r, r)$, for r any positive real number;
- (x) \mathcal{T}_{10} consists of \mathbb{R} , \emptyset , every interval $[-n, n]$, and every interval $(-r, r)$, for n any positive integer and r any positive real number.

1.2 Open Sets, Closed Sets, and Clopen Sets

Rather than continually refer to “members of \mathcal{T} ”, we find it more convenient to give such sets a name. We call them “open sets”. We shall also name the complements of open sets. They will be called “closed sets”. This nomenclature is not ideal, but derives from the so-called “open intervals” and “closed intervals” on the real number line. We shall have more to say about this in Chapter 2.

1.2.1 Definition. Let (X, \mathcal{T}) be any topological space. Then the members of \mathcal{T} are said to be **open sets**.

1.2.2 Proposition. If (X, \mathcal{T}) is any topological space, then

- (i) X and \emptyset are open sets,
- (ii) the union of any (finite or infinite) number of open sets is an open set and
- (iii) the intersection of any finite number of open sets is an open set.

Proof. Clearly (i) and (ii) are trivial consequences of Definition 1.2.1 and Definitions 1.1.1 (i) and (ii). The condition (iii) follows from Definition 1.2.1 and Exercises 1.1 #4. \square

On reading Proposition 1.2.2, a question should have popped into your mind: while any finite or infinite union of open sets is open, we state only that finite intersections of open sets are open. Are infinite intersections of open sets always open? The next example shows that the answer is “no”.

1.2.3 Example. Let \mathbb{N} be the set of all positive integers and let \mathcal{T} consist of \emptyset and each subset S of \mathbb{N} such that the complement of S in \mathbb{N} , $\mathbb{N} \setminus S$, is a finite set. It is easily verified that \mathcal{T} satisfies Definitions 1.1.1 and so is a topology on \mathbb{N} . (In the next section we shall discuss this topology further. It is called the finite-closed topology.) For each natural number n , define the set S_n as follows:

$$S_n = \{1\} \cup \{n+1\} \cup \{n+2\} \cup \{n+3\} \cup \cdots = \{1\} \cup \bigcup_{m=n+1}^{\infty} \{m\}.$$

Clearly each S_n is an open set in the topology \mathcal{T} , since its complement is a finite set. However,

$$\bigcap_{n=1}^{\infty} S_n = \{1\}. \quad (1)$$

As the complement of $\{1\}$ is neither \mathbb{N} nor a finite set, $\{1\}$ is not open. So (1) shows that the intersection of the open sets S_n is not open. \square

You might well ask: how did you find the example presented in Example 1.2.3? The answer is unglamorous! It was by trial and error.

If we tried, for example, a discrete topology, we would find that each intersection of open sets is indeed open. The same is true of the indiscrete topology. So what you need to do is some intelligent guesswork.

Remember that to prove that the intersection of open sets is not necessarily open, you need to find just one counterexample!

1.2.4 Definition. Let (X, \mathcal{T}) be a topological space. A subset S of X is said to be a **closed set** in (X, \mathcal{T}) if its complement in X , namely $X \setminus S$, is open in (X, \mathcal{T}) .

In Example 1.1.2, the closed sets are

$$\emptyset, X, \{b, c, d, e, f\}, \{a, b, e, f\}, \{b, e, f\} \text{ and } \{a\}.$$

If (X, \mathcal{T}) is a discrete space, then it is obvious that every subset of X is a closed set. However in an indiscrete space, (X, \mathcal{T}) , the only closed sets are X and \emptyset .

1.2.5 Proposition. If (X, \mathcal{T}) is any topological space, then

- (i) \emptyset and X are closed sets,
- (ii) the intersection of any (finite or infinite) number of closed sets is a closed set and
- (iii) the union of any finite number of closed sets is a closed set.

Proof. (i) follows immediately from Proposition 1.2.2 (i) and Definition 1.2.4, as the complement of X is \emptyset and the complement of \emptyset is X .

To prove that (iii) is true, let S_1, S_2, \dots, S_n be closed sets. We are required to prove that $S_1 \cup S_2 \cup \dots \cup S_n$ is a closed set. It suffices to show, by Definition 1.2.4, that $X \setminus (S_1 \cup S_2 \cup \dots \cup S_n)$ is an open set.

As S_1, S_2, \dots, S_n are closed sets, their complements $X \setminus S_1, X \setminus S_2, \dots, X \setminus S_n$ are open sets. But

$$X \setminus (S_1 \cup S_2 \cup \dots \cup S_n) = (X \setminus S_1) \cap (X \setminus S_2) \cap \dots \cap (X \setminus S_n). \quad (1)$$

As the right hand side of (1) is a finite intersection of open sets, it is an open set. So the left hand side of (1) is an open set. Hence $S_1 \cup S_2 \cup \dots \cup S_n$ is a closed set, as required. So (iii) is true.

The proof of (ii) is similar to that of (iii). [However, you should read the warning in the proof of Example 1.3.9.] □

Warning. The names “open” and “closed” often lead newcomers to the world of topology into error. Despite the names, some open sets are also closed sets! Moreover, some sets are neither open sets nor closed sets! Indeed, if we consider Example 1.1.2 we see that

- (i) the set $\{a\}$ is both open and closed;
- (ii) the set $\{b, c\}$ is neither open nor closed;
- (iii) the set $\{c, d\}$ is open but not closed;
- (iv) the set $\{a, b, e, f\}$ is closed but not open.

In a discrete space every set is both open and closed, while in an indiscrete space (X, \mathcal{T}) , all subsets of X except X and \emptyset are neither open nor closed. \square

To remind you that sets can be both open and closed we introduce the following definition.

1.2.6 Definition. A subset S of a topological space (X, \mathcal{T}) is said to be **clopen** if it is both open and closed in (X, \mathcal{T}) .

In every topological space (X, \mathcal{T}) both X and \emptyset are clopen¹.

In a discrete space all subsets of X are clopen.

In an indiscrete space the only clopen subsets are X and \emptyset .

Exercises 1.2

1. List all 64 subsets of the set X in Example 1.1.2. Write down, next to each set, whether it is (i) clopen; (ii) neither open nor closed; (iii) open but not closed; (iv) closed but not open.
2. Let (X, \mathcal{T}) be a topological space with the property that every subset is closed. Prove that it is a discrete space.

¹We admit that “clopen” is an ugly word but its use is now widespread.

3. Observe that if (X, \mathcal{T}) is a discrete space or an indiscrete space, then every open set is a clopen set. Find a topology \mathcal{T} on the set $X = \{a, b, c, d\}$ which is not discrete and is not indiscrete but has the property that every open set is clopen.
4. Let X be an infinite set. If \mathcal{T} is a topology on X such that every infinite subset of X is closed, prove that \mathcal{T} is the discrete topology.
5. Let X be an infinite set and \mathcal{T} a topology on X with the property that the only infinite subset of X which is open is X itself. Is (X, \mathcal{T}) necessarily an indiscrete space?
6. (i) Let \mathcal{T} be a topology on a set X such that \mathcal{T} consists of precisely four sets; that is, $\mathcal{T} = \{X, \emptyset, A, B\}$, where A and B are non-empty distinct proper subsets of X . [A is a **proper subset** of X means that $A \subseteq X$ and $A \neq X$. This is denoted by $A \subset X$.] Prove that A and B must satisfy exactly one of the following conditions:

$$(a) B = X \setminus A; \quad (b) A \subset B; \quad (c) B \subset A.$$

[Hint. Firstly show that A and B must satisfy at least one of the conditions and then show that they cannot satisfy more than one of the conditions.]

- (ii) Using (i) list all topologies on $X = \{1, 2, 3, 4\}$ which consist of exactly four sets.

1.3 The Finite-Closed Topology

It is usual to define a topology on a set by stating which sets are open. However, sometimes it is more natural to describe the topology by saying which sets are closed. The next definition provides one such example.

1.3.1 Definition. Let X be any non-empty set. A topology \mathcal{T} on X is called the **finite-closed topology** or the **cofinite topology** if the closed subsets of X are X and all finite subsets of X ; that is, the open sets are \emptyset and all subsets of X which have finite complements.

Once again it is necessary to check that \mathcal{T} in Definition 1.3.1 is indeed a topology; that is, that it satisfies each of the conditions of Definitions 1.1.1.

Note that Definition 1.3.1 does not say that every topology which has X and the finite subsets of X closed is the finite-closed topology. These must be the only closed sets. [Of course, in the discrete topology on any set X , the set X and all finite subsets of X are indeed closed, but so too are all other subsets of X .]

In the finite-closed topology all finite sets are closed. However, the following example shows that infinite subsets need not be open sets.

1.3.2 Example. If \mathbb{N} is the set of all positive integers, then sets such as $\{1\}$, $\{5, 6, 7\}$, $\{2, 4, 6, 8\}$ are finite and hence closed in the finite-closed topology. Thus their complements

$$\{2, 3, 4, 5, \dots\}, \{1, 2, 3, 4, 8, 9, 10, \dots\}, \{1, 3, 5, 7, 9, 10, 11, \dots\}$$

are open sets in the finite-closed topology. On the other hand, the set of even positive integers is not a closed set since it is not finite and hence its complement, the set of odd positive integers, is not an open set in the finite-closed topology.

So while all finite sets are closed, not all infinite sets are open. □

1.3.3 Example. Let \mathcal{T} be the finite-closed topology on a set X . If X has at least 3 distinct clopen subsets, prove that X is a finite set.

Proof.

We are given that \mathcal{T} is the finite-closed topology, and that there are at least 3 distinct clopen subsets.

We are required to prove that X is a finite set.

Recall that \mathcal{T} is the finite-closed topology means that the family of all closed sets consists of X and all finite subsets of X . Recall also that a set is clopen if and only if it is both closed and open.

Remember that in every topological space there are at least 2 clopen sets, namely X and \emptyset . (See the comment immediately following Definition 1.2.6.) But we are told that in the space (X, \mathcal{T}) there are at least 3 clopen subsets. This implies that there is a clopen subset other than \emptyset and X . So we shall have a careful look at this other clopen set!

As our space (X, \mathcal{T}) has 3 distinct clopen subsets, we know that there is a clopen subset S of X such that $S \neq X$ and $S \neq \emptyset$. As S is open in (X, \mathcal{T}) , Definition 1.2.4 implies that its complement $X \setminus S$ is a closed set.

Thus S and $X \setminus S$ are closed in the finite-closed topology \mathcal{T} . Therefore S and $X \setminus S$ are both finite, since neither equals X . But $X = S \cup (X \setminus S)$ and so X is the union of two finite sets. Thus X is a finite set, as required. \square

We now know three distinct topologies we can put on any infinite set – and there are many more. The three we know are the discrete topology, the indiscrete topology, and the finite-closed topology. So we must be careful always to specify the topology on a set.

For example, the set $\{n : n \geq 10\}$ is open in the finite-closed topology on the set of natural numbers, but is not open in the indiscrete topology. The set of odd natural numbers is open in the discrete topology on the set of natural numbers, but is not open in the finite-closed topology.

We shall now record some definitions which you have probably met before.

1.3.4 Definitions. Let f be a function from a set X into a set Y .

- (i) The function f is said to be **one-to-one** or **injective** if $f(x_1) = f(x_2)$ implies $x_1 = x_2$, for $x_1, x_2 \in X$;
- (ii) The function f is said to be **onto** or **surjective** if for each $y \in Y$ there exists an $x \in X$ such that $f(x) = y$;
- (iii) The function f is said to be **bijjective** if it is both one-to-one and onto.

1.3.5 Definitions. Let f be a function from a set X into a set Y . The function f is said to **have an inverse** if there exists a function g of Y into X such that $g(f(x)) = x$, for all $x \in X$ and $f(g(y)) = y$, for all $y \in Y$. The function g is called an **inverse function** of f .

The proof of the following proposition is left as an exercise for you.

1.3.6 Proposition. Let f be a function from a set X into a set Y .

- (i) The function f has an inverse if and only if f is bijective.
- (ii) Let g_1 and g_2 be functions from Y into X . If g_1 and g_2 are both inverse functions of f , then $g_1 = g_2$; that is, $g_1(y) = g_2(y)$, for all $y \in Y$.
- (iii) Let g be a function from Y into X . Then g is an inverse function of f if and only if f is an inverse function of g .

Warning. It is a very common error for students to think that a function is one-to-one if “it maps one point to one point”.

All functions map one point to one point. Indeed this is part of the definition of a function.

A one-to-one function is a function that maps different points to different points. \square

We now turn to a very important notion that you may not have met before.

1.3.7 Definition. Let f be a function from a set X into a set Y . If S is any subset of Y , then the set $f^{-1}(S)$ is defined by

$$f^{-1}(S) = \{x : x \in X \text{ and } f(x) \in S\}.$$

The subset $f^{-1}(S)$ of X is said to be the **inverse image** of S .

Note that an inverse function of $f: X \rightarrow Y$ exists if and only if f is bijective. But the inverse image of any subset of Y exists even if f is neither one-to-one nor onto. The next example demonstrates this.

1.3.8 Example. Let f be the function from the set of integers, \mathbb{Z} , into itself given by $f(z) = |z|$, for each $z \in \mathbb{Z}$.

The function f is not one-to one, since $f(1) = f(-1)$.

It is also not onto, since there is no $z \in \mathbb{Z}$, such that $f(z) = -1$. So f is certainly not bijective. Hence, by Proposition 1.3.6 (i), f does not have an inverse function. However inverse images certainly exist. For example,

$$f^{-1}(\{1, 2, 3\}) = \{-1, -2, -3, 1, 2, 3\}$$

$$f^{-1}(\{-5, 3, 5, 7, 9\}) = \{-3, -5, -7, -9, 3, 5, 7, 9\}.$$

□

We conclude this section with an interesting example.

1.3.9 Example. Let (Y, \mathcal{T}) be a topological space and X a non-empty set. Further, let f be a function from X into Y . Put $\mathcal{T}_1 = \{f^{-1}(S) : S \in \mathcal{T}\}$. Prove that \mathcal{T}_1 is a topology on X .

Proof.

Our task is to show that the collection of sets, \mathcal{T}_1 , is a topology on X ; that is, we have to show that \mathcal{T}_1 satisfies conditions (i), (ii) and (iii) of Definitions

1.1.1.

$$X \in \mathcal{T}_1 \quad \text{since} \quad X = f^{-1}(Y) \quad \text{and} \quad Y \in \mathcal{T}.$$

$$\emptyset \in \mathcal{T}_1 \quad \text{since} \quad \emptyset = f^{-1}(\emptyset) \quad \text{and} \quad \emptyset \in \mathcal{T}.$$

Therefore \mathcal{T}_1 has property (i) of Definitions 1.1.1.

To verify condition (ii) of Definitions 1.1.1, let $\{A_j : j \in J\}$ be a collection of members of \mathcal{T}_1 , for some index set J . We have to show that $\bigcup_{j \in J} A_j \in \mathcal{T}_1$. As $A_j \in \mathcal{T}_1$, the definition of \mathcal{T}_1 implies that $A_j = f^{-1}(B_j)$, where $B_j \in \mathcal{T}$. Also $\bigcup_{j \in J} A_j = \bigcup_{j \in J} f^{-1}(B_j) = f^{-1}\left(\bigcup_{j \in J} B_j\right)$. [See Exercises 1.3 # 1.]

Now $B_j \in \mathcal{T}$, for all $j \in J$, and so $\bigcup_{j \in J} B_j \in \mathcal{T}$, since \mathcal{T} is a topology on Y . Therefore, by the definition of \mathcal{T}_1 , $f^{-1}\left(\bigcup_{j \in J} B_j\right) \in \mathcal{T}_1$; that is, $\bigcup_{j \in J} A_j \in \mathcal{T}_1$.

So \mathcal{T}_1 has property (ii) of Definitions 1.1.1.

[Warning. You are reminded that not all sets are countable. (See the Appendix for comments on countable sets.) So it would not suffice, in the above argument, to assume that sets $A_1, A_2, \dots, A_n, \dots$ are in \mathcal{T}_1 and show that their union $A_1 \cup A_2 \cup \dots \cup A_n \cup \dots$ is in \mathcal{T}_1 . This would prove only that the union of a countable number of sets in \mathcal{T}_1 lies in \mathcal{T}_1 , but would not show that \mathcal{T}_1 has property (ii) of Definitions 1.1.1 – this property requires all unions, whether countable or uncountable, of sets in \mathcal{T}_1 to be in \mathcal{T}_1 .]

Finally, let A_1 and A_2 be in \mathcal{T}_1 . We have to show that $A_1 \cap A_2 \in \mathcal{T}_1$.

As $A_1, A_2 \in \mathcal{T}_1$, $A_1 = f^{-1}(B_1)$ and $A_2 = f^{-1}(B_2)$, where $B_1, B_2 \in \mathcal{T}$.

$$A_1 \cap A_2 = f^{-1}(B_1) \cap f^{-1}(B_2) = f^{-1}(B_1 \cap B_2).$$

[See Exercises 1.3 #1.]

As $B_1 \cap B_2 \in \mathcal{T}$, we have $f^{-1}(B_1 \cap B_2) \in \mathcal{T}_1$. Hence $A_1 \cap A_2 \in \mathcal{T}_1$, and we have shown that \mathcal{T}_1 also has property (iii) of Definitions 1.1.1.

So \mathcal{T}_1 is indeed a topology on X . □

Exercises 1.3

1. Let f be a function from a set X into a set Y . Then we stated in Example 1.3.9 that

$$f^{-1}\left(\bigcup_{j \in J} B_j\right) = \bigcup_{j \in J} f^{-1}(B_j) \quad (1)$$

and

$$f^{-1}(B_1 \cap B_2) = f^{-1}(B_1) \cap f^{-1}(B_2) \quad (2)$$

for any subsets B_j of Y , and any index set J .

(a) Prove that (1) is true.

[Hint. Start your proof by letting x be any element of the set on the left-hand side and show that it is in the set on the right-hand side. Then do the reverse.]

(b) Prove that (2) is true.

(c) Find (concrete) sets A_1, A_2, X , and Y and a function $f: X \rightarrow Y$ such that $f(A_1 \cap A_2) \neq f(A_1) \cap f(A_2)$, where $A_1 \subseteq X$ and $A_2 \subseteq X$.

2. Is the topology \mathcal{T} described in Exercises 1.1 #6 (ii) the finite-closed topology? (Justify your answer.)

3. A topological space (X, \mathcal{T}) is said to be a **T_1 -space** if every singleton set $\{x\}$ is closed in (X, \mathcal{T}) . Show that precisely two of the following nine topological spaces are T_1 -spaces. (Justify your answer.)
- (i) a discrete space;
 - (ii) an indiscrete space with at least two points;
 - (iii) an infinite set with the finite-closed topology;
 - (iv) Example 1.1.2;
 - (v) Exercises 1.1 #5 (i);
 - (vi) Exercises 1.1 #5 (ii);
 - (vii) Exercises 1.1 #5 (iii);
 - (viii) Exercises 1.1 #6 (i);
 - (ix) Exercises 1.1 #6 (ii).
4. Let \mathcal{T} be the finite-closed topology on a set X . If \mathcal{T} is also the discrete topology, prove that the set X is finite.
5. A topological space (X, \mathcal{T}) is said to be a **T_0 -space** if for each pair of distinct points a, b in X , either there exists an open set containing a and not b , or there exists an open set containing b and not a .
- (i) Prove that every T_1 -space is a T_0 -space.
 - (ii) Which of (i)–(vi) in Exercise 3 above are T_0 -spaces? (Justify your answer.)
 - (iii) Put a topology \mathcal{T} on the set $X = \{0, 1\}$ so that (X, \mathcal{T}) will be a T_0 -space but not a T_1 -space. [The topological space you obtain is called the **Sierpinski space**.]
 - (iv) Prove that each of the topological spaces described in Exercises 1.1 #6 is a T_0 -space. (Observe that in Exercise 3 above we saw that neither is a T_1 -space.)
6. Let X be any infinite set. The **countable-closed topology** is defined to be the topology having as its closed sets X and all countable subsets of X . Prove that this is indeed a topology on X .
7. Let \mathcal{T}_1 and \mathcal{T}_2 be two topologies on a set X . Prove each of the following statements.

- (i) If \mathcal{T}_3 is defined by $\mathcal{T}_3 = \mathcal{T}_1 \cup \mathcal{T}_2$, then \mathcal{T}_3 is not necessarily a topology on X . (Justify your answer, by finding a concrete example.)
- (ii) If \mathcal{T}_4 is defined by $\mathcal{T}_4 = \mathcal{T}_1 \cap \mathcal{T}_2$, then \mathcal{T}_4 is a topology on X . (The topology \mathcal{T}_4 is said to be the **intersection** of the topologies \mathcal{T}_1 and \mathcal{T}_2 .)
- (iii) If (X, \mathcal{T}_1) and (X, \mathcal{T}_2) are T_1 -spaces, then (X, \mathcal{T}_4) is also a T_1 -space.
- (iv) If (X, \mathcal{T}_1) and (X, \mathcal{T}_2) are T_0 -spaces, then (X, \mathcal{T}_4) is not necessarily a T_0 -space. (Justify your answer by finding a concrete example.)
- (v) If $\mathcal{T}_1, \mathcal{T}_2, \dots, \mathcal{T}_n$ are topologies on a set X , then $\mathcal{T} = \bigcap_{i=1}^n \mathcal{T}_i$ is a topology on X .
- (vi) If for each $i \in I$, for some index set I , each \mathcal{T}_i is a topology on the set X , then $\mathcal{T} = \bigcap_{i \in I} \mathcal{T}_i$ is a topology on X .

1.4 Postscript

In this chapter we introduced the fundamental notion of a topological space. As examples we saw various finite spaces, as well as discrete spaces, indiscrete spaces and spaces with the finite-closed topology. None of these is a particularly important example as far as applications are concerned. However, in Exercises 4.3 #8, it is noted that every infinite topological space “contains” an infinite topological space with one of the five topologies: the indiscrete topology, the discrete topology, the finite-closed topology, the initial segment topology, or the final segment topology of Exercises 1.1 #6. In the next chapter we describe the very important euclidean topology.

En route we met the terms “open set” and “closed set” and we were warned that these names can be misleading. Sets can be both open and closed, neither open nor closed, open but not closed, or closed but not open. It is important to remember that we cannot prove that a set is open by proving that it is not closed.

Other than the definitions of topology, topological space, open set, and closed set the most significant topic covered was that of writing proofs.

In the opening comments of this chapter we pointed out the importance of learning to write proofs. In Example 1.1.8, Proposition 1.1.9, and Example 1.3.3 we have seen how to “think through” a proof. It is essential that you develop your own skill at writing proofs. Good exercises to try for this purpose include Exercises 1.1 #8, Exercises 1.2 #2,4, and Exercises 1.3 #1,4.

Some students are confused by the notion of topology as it involves “sets of sets”. To check your understanding, do Exercises 1.1 #3.

The exercises included the notions of T_0 -space and T_1 -space which will be formally introduced later. These are known as **separation properties**.

Finally we emphasize the importance of inverse images. These are dealt with in Example 1.3.9 and Exercises 1.3 #1. Our definition of continuous mapping will rely on inverse images.

Chapter 2

The Euclidean Topology

Introduction

In a movie or a novel there are usually a few central characters about whom the plot revolves. In the story of topology, the euclidean topology on the set of real numbers is one of the central characters. Indeed it is such a rich example that we shall frequently return to it for inspiration and further examination.

Let \mathbb{R} denote the set of all real numbers. In Chapter 1 we defined three topologies that can be put on any set: the discrete topology, the indiscrete topology and the finite-closed topology. So we know three topologies that can be put on the set \mathbb{R} . Six other topologies on \mathbb{R} were defined in Exercises 1.1 #5 and #9. In this chapter we describe a much more important and interesting topology on \mathbb{R} which is known as the euclidean topology.

An analysis of the euclidean topology leads us to the notion of “basis for a topology”. In the study of Linear Algebra we learn that every vector space has a basis and every vector is a linear combination of members of the basis. Similarly, in a topological space every open set can be expressed as a union of members of the basis. Indeed, a set is open if and only if it is a union of members of the basis.

2.1 The Euclidean Topology on \mathbb{R}

2.1.1 Definition. A subset S of \mathbb{R} is said to be open in the **euclidean topology on \mathbb{R}** if it has the following property:

(*) For each $x \in S$, there exist a, b in \mathbb{R} , with $a < b$, such that $x \in (a, b) \subseteq S$.

Notation. Whenever we refer to the topological space \mathbb{R} without specifying the topology, we mean \mathbb{R} with the euclidean topology.

2.1.2 Remarks. (i) The “euclidean topology” \mathcal{T} is a topology.

Proof.

We are required to show that \mathcal{T} satisfies conditions (i), (ii), and (iii) of Definitions 1.1.1.

We are given that a set is in \mathcal{T} if and only if it has property *.

Firstly, we show that $\mathbb{R} \in \mathcal{T}$. Let $x \in \mathbb{R}$. If we put $a = x - 1$ and $b = x + 1$, then $x \in (a, b) \subseteq \mathbb{R}$; that is, \mathbb{R} has property * and so $\mathbb{R} \in \mathcal{T}$. Secondly, $\emptyset \in \mathcal{T}$ as \emptyset has property * by default.

Now let $\{A_j : j \in J\}$, for some index set J , be a family of members of \mathcal{T} . Then we have to show that $\bigcup_{j \in J} A_j \in \mathcal{T}$; that is, we have to show that $\bigcup_{j \in J} A_j$ has property *. Let $x \in \bigcup_{j \in J} A_j$. Then $x \in A_k$, for some $k \in J$. As $A_k \in \mathcal{T}$, there exist a and b in \mathbb{R} with $a < b$ such that $x \in (a, b) \subseteq A_k$. As $k \in J$, $A_k \subseteq \bigcup_{j \in J} A_j$ and so $x \in (a, b) \subseteq \bigcup_{j \in J} A_j$. Hence $\bigcup_{j \in J} A_j$ has property * and thus is in \mathcal{T} , as required.

Finally, let A_1 and A_2 be in \mathcal{T} . We have to prove that $A_1 \cap A_2 \in \mathcal{T}$. So let $y \in A_1 \cap A_2$. Then $y \in A_1$. As $A_1 \in \mathcal{T}$, there exist a and b in \mathbb{R} with $a < b$ such that $y \in (a, b) \subseteq A_1$. Also $y \in A_2 \in \mathcal{T}$. So there exist c and d in \mathbb{R} with $c < d$ such that $y \in (c, d) \subseteq A_2$. Let e be the greater of a and c , and f the smaller of b and d . It is easily checked that $e < y < f$, and so $y \in (e, f)$. As $(e, f) \subseteq (a, b) \subseteq A_1$ and $(e, f) \subseteq (c, d) \subseteq A_2$, we deduce that $y \in (e, f) \subseteq A_1 \cap A_2$. Hence $A_1 \cap A_2$ has property * and so is in \mathcal{T} .

Thus \mathcal{T} is indeed a topology on \mathbb{R} . □

We now proceed to describe the open sets and the closed sets in the euclidean topology on \mathbb{R} . In particular, we shall see that all open intervals are indeed open sets in this topology and all closed intervals are closed sets.

(ii) Let $r, s \in \mathbb{R}$ with $r < s$. In the euclidean topology \mathcal{T} on \mathbb{R} , the open interval (r, s) does indeed belong to \mathcal{T} and so is an open set.

Proof.

We are given the open interval (r, s) .

We must show that (r, s) is open in the euclidean topology; that is, we have to show that (r, s) has property (*) of Definition 2.1.1.

So we shall begin by letting $x \in (r, s)$. We want to find a and b in \mathbb{R} with $a < b$ such that $x \in (a, b) \subseteq (r, s)$.

Let $x \in (r, s)$. Choose $a = r$ and $b = s$. Then clearly

$$x \in (a, b) \subseteq (r, s).$$

So (r, s) is an open set in the euclidean topology. □

(iii) The open intervals (r, ∞) and $(-\infty, r)$ are open sets in \mathbb{R} , for every real number r .

Proof.

Firstly, we shall show that (r, ∞) is an open set; that is, that it has property (*).

To show this we let $x \in (r, \infty)$ and seek $a, b \in \mathbb{R}$ such that

$$x \in (a, b) \subseteq (r, \infty).$$

Let $x \in (r, \infty)$. Put $a = r$ and $b = x + 1$. Then $x \in (a, b) \subseteq (r, \infty)$ and so $(r, \infty) \in \mathcal{T}$.

A similar argument shows that $(-\infty, r)$ is an open set in \mathbb{R} . □

(iv) It is important to note that while every open interval is an open set in \mathbb{R} , the converse is false. **Not all open sets in \mathbb{R} are intervals.** For example, the set $(1, 3) \cup (5, 6)$ is an open set in \mathbb{R} , but it is not an open interval. Even the set $\bigcup_{n=1}^{\infty} (2n, 2n + 1)$ is an open set in \mathbb{R} . \square

(v) For each c and d in \mathbb{R} with $c < d$, the closed interval $[c, d]$ is not an open set in \mathbb{R} .

Proof.

We have to show that $[c, d]$ does not have property (*).

To do this it suffices to find any one x such that there is no a, b having property (*).

Obviously c and d are very special points in the interval $[c, d]$. So we shall choose $x = c$ and show that no a, b with the required property exist.

We use the method of proof called **proof by contradiction**. We **suppose** that a and b exist with the required property and show that this leads to a contradiction, that is something which is false. Consequently the supposition is false! Hence no such a and b exist. Thus $[c, d]$ does not have property (*) and so is not an open set.

Observe that $c \in [c, d]$. **Suppose** there exist a and b in \mathbb{R} with $a < b$ such that $c \in (a, b) \subseteq [c, d]$. Then $c \in (a, b)$ implies $a < c < b$ and so $a < \frac{c+a}{2} < c < b$. Thus $\frac{c+a}{2} \in (a, b)$ and $\frac{c+a}{2} \notin [c, d]$. Hence $(a, b) \not\subseteq [c, d]$, which is a contradiction. So there do not exist a and b such that $c \in (a, b) \subseteq [c, d]$. Hence $[c, d]$ does not have property (*) and so $[c, d] \notin \mathcal{T}$. \square

(vi) For each a and b in \mathbb{R} with $a < b$, the closed interval $[a, b]$ is a closed set in the euclidean topology on \mathbb{R} .

Proof. To see that it is closed we have to observe only that its complement $(-\infty, a) \cup (b, \infty)$, being the union of two open sets, is an open set. \square

(vii) Each singleton set $\{a\}$ is closed in \mathbb{R} .

Proof. The complement of $\{a\}$ is the union of the two open sets $(-\infty, a)$ and (a, ∞) and so is open. Therefore $\{a\}$ is closed in \mathbb{R} , as required.

[In the terminology of Exercises 1.3 #3, this result says that \mathbb{R} is a T_1 -space.] \square

(viii) Note that we could have included (vii) in (vi) simply by replacing " $a < b$ " by " $a \leq b$ ". The singleton set $\{a\}$ is just the degenerate case of the closed interval $[a, b]$. \square

(ix) The set \mathbb{Z} of all integers is a closed subset of \mathbb{R} .

Proof. The complement of \mathbb{Z} is the union $\bigcup_{n=-\infty}^{\infty} (n, n+1)$ of open subsets $(n, n+1)$ of \mathbb{R} and so is open in \mathbb{R} . Therefore \mathbb{Z} is closed in \mathbb{R} . \square

(x) The set \mathbb{Q} of all rational numbers is neither a closed subset of \mathbb{R} nor an open subset of \mathbb{R} .

Proof.

We shall show that \mathbb{Q} is not an open set by proving that it does not have property (*).

To do this it suffices to show that \mathbb{Q} does not contain any interval (a, b) , with $a < b$.

Suppose that $(a, b) \subseteq \mathbb{Q}$, where a and b are in \mathbb{R} with $a < b$. Between any two distinct real numbers there is an irrational number. (Can you prove this?) Therefore there exists $c \in (a, b)$ such that $c \notin \mathbb{Q}$. This contradicts $(a, b) \subseteq \mathbb{Q}$. Hence \mathbb{Q} does not contain any interval (a, b) , and so is not an open set.

To prove that \mathbb{Q} is not a closed set it suffices to show that $\mathbb{R} \setminus \mathbb{Q}$ is not an open set. Using the fact that between any two distinct real numbers there is a rational number we see that $\mathbb{R} \setminus \mathbb{Q}$ does not contain any interval (a, b) with $a < b$. So $\mathbb{R} \setminus \mathbb{Q}$ is not open in \mathbb{R} and hence \mathbb{Q} is not closed in \mathbb{R} . \square

(xi) In Chapter 3 we shall prove that the only clopen subsets of \mathbb{R} are the trivial ones, namely \mathbb{R} and \emptyset . \square

 Exercises 2.1

1. Prove that if $a, b \in \mathbb{R}$ with $a < b$ then neither $[a, b)$ nor $(a, b]$ is an open subset of \mathbb{R} . Also show that neither is a closed subset of \mathbb{R} .
2. Prove that the sets $[a, \infty)$ and $(-\infty, a]$ are closed subsets of \mathbb{R} .
3. Show, by example, that the union of an infinite number of closed subsets of \mathbb{R} is not necessarily a closed subset of \mathbb{R} .
4. Prove each of the following statements.
 - (i) The set \mathbb{Z} of all integers is not an open subset of \mathbb{R} .
 - (ii) The set S of all prime numbers is a closed subset of \mathbb{R} but not an open subset of \mathbb{R} .
 - (iii) The set \mathbb{P} of all irrational numbers is neither a closed subset nor an open subset of \mathbb{R} .
5. If F is a non-empty finite subset of \mathbb{R} , show that F is closed in \mathbb{R} but that F is not open in \mathbb{R} .
6. If F is a non-empty countable subset of \mathbb{R} , prove that F is not an open set.
7. (i) Let $S = \{0, 1, 1/2, 1/3, 1/4, 1/5, \dots, 1/n, \dots\}$. Prove that the set S is closed in the euclidean topology on \mathbb{R} .
 - (ii) Is the set $T = \{1, 1/2, 1/3, 1/4, 1/5, \dots, 1/n, \dots\}$ closed in \mathbb{R} ?
 - (iii) Is the set $\{\sqrt{2}, 2\sqrt{2}, 3\sqrt{2}, \dots, n\sqrt{2}, \dots\}$ closed in \mathbb{R} ?
8. (i) Let (X, \mathcal{T}) be a topological space. A subset S of X is said to be an **F_σ -set** if it is the union of a countable number of closed sets. Prove that all open intervals (a, b) and all closed intervals $[a, b]$, are F_σ -sets in \mathbb{R} .
 - (ii) Let (X, \mathcal{T}) be a topological space. A subset T of X is said to be a **G_δ -set** if it is the intersection of a countable number of open sets. Prove that all open intervals (a, b) and all closed intervals $[a, b]$ are G_δ -sets in \mathbb{R} .
 - (iii) Prove that the set \mathbb{Q} of rationals is an F_σ -set in \mathbb{R} . (In Exercises 6.5#3 we prove that \mathbb{Q} is not a G_δ -set in \mathbb{R} .)
 - (iv) Verify that the complement of an F_σ -set is a G_δ -set and the complement of a G_δ -set is an F_σ -set.

2.2 Basis for a Topology

Remarks 2.1.2 allow us to describe the euclidean topology on \mathbb{R} in a much more convenient manner. To do this, we introduce the notion of a basis for a topology.

2.2.1 Proposition. A subset S of \mathbb{R} is open if and only if it is a union of open intervals.

Proof.

We are required to prove that S is open if and only if it is a union of open intervals; that is, we have to show that

- (i) if S is a union of open intervals, then it is an open set, and
- (ii) if S is an open set, then it is a union of open intervals.

Assume that S is a union of open intervals; that is, there exist open intervals (a_j, b_j) , where j belongs to some index set J , such that $S = \bigcup_{j \in J} (a_j, b_j)$. By Remarks 2.1.2 (ii) each open interval (a_j, b_j) is an open set. Thus S is a union of open sets and so S is an open set.

Conversely, assume that S is open in \mathbb{R} . Then for each $x \in S$, there exists an interval $I_x = (a, b)$ such that $x \in I_x \subseteq S$. We now claim that $S = \bigcup_{x \in S} I_x$.

We are required to show that the two sets S and $\bigcup_{x \in S} I_x$ are equal.

These sets are shown to be equal by proving that

- (i) if $y \in S$, then $y \in \bigcup_{x \in S} I_x$, and
- (ii) if $z \in \bigcup_{x \in S} I_x$, then $z \in S$.

[Note that (i) is equivalent to the statement $S \subseteq \bigcup_{x \in S} I_x$, while (ii) is equivalent to $\bigcup_{x \in S} I_x \subseteq S$.]

Firstly let $y \in S$. Then $y \in I_y$. So $y \in \bigcup_{x \in S} I_x$, as required. Secondly, let $z \in \bigcup_{x \in S} I_x$. Then $z \in I_t$, for some $t \in S$. As each $I_x \subseteq S$, we see that $I_t \subseteq S$ and so $z \in S$. Hence $S = \bigcup_{x \in S} I_x$, and we have that S is a union of open intervals, as required. \square

The above proposition tells us that in order to describe the topology of \mathbb{R} it suffices to say that all intervals (a, b) are open sets. Every other open set is a union of these open sets. This leads us to the following definition.

2.2.2 Definition. Let (X, \mathcal{T}) be a topological space. A collection \mathcal{B} of open subsets of X is said to be a **basis** for the topology \mathcal{T} if every open set is a union of members of \mathcal{B} .

If \mathcal{B} is a basis for a topology \mathcal{T} on a set X then a subset U of X is in \mathcal{T} if and only if it is a union of members of \mathcal{B} . So \mathcal{B} “generates” the topology \mathcal{T} in the following sense: if we are told what sets are members of \mathcal{B} then we can determine the members of \mathcal{T} – they are just all the sets which are unions of members of \mathcal{B} .

2.2.3 Example. Let $\mathcal{B} = \{(a, b) : a, b \in \mathbb{R}, a < b\}$. Then \mathcal{B} is a basis for the euclidean topology on \mathbb{R} , by Proposition 2.2.1. □

2.2.4 Example. Let (X, \mathcal{T}) be a discrete space and \mathcal{B} the family of all singleton subsets of X ; that is, $\mathcal{B} = \{\{x\} : x \in X\}$. Then, by Proposition 1.1.9, \mathcal{B} is a basis for \mathcal{T} . □

2.2.5 Example. Let $X = \{a, b, c, d, e, f\}$ and

$$\mathcal{T}_1 = \{X, \emptyset, \{a\}, \{c, d\}, \{a, c, d\}, \{b, c, d, e, f\}\}.$$

Then $\mathcal{B} = \{\{a\}, \{c, d\}, \{b, c, d, e, f\}\}$ is a basis for \mathcal{T}_1 as $\mathcal{B} \subseteq \mathcal{T}_1$ and every member of \mathcal{T}_1 can be expressed as a union of members of \mathcal{B} . (Observe that \emptyset is an empty union of members of \mathcal{B} .)

Note that \mathcal{T}_1 itself is also a basis for \mathcal{T}_1 . □

2.2.6 Remark. Observe that if (X, \mathcal{T}) is a topological space then $\mathcal{B} = \mathcal{T}$ is a basis for the topology \mathcal{T} . So, for example, the set of all subsets of X is a basis for the discrete topology on X .

We see, therefore, that [there can be many different bases for the same topology](#). Indeed if \mathcal{B} is a basis for a topology \mathcal{T} on a set X and \mathcal{B}_1 is a collection of subsets of X such that $\mathcal{B} \subseteq \mathcal{B}_1 \subseteq \mathcal{T}$, then \mathcal{B}_1 is also a basis for \mathcal{T} . [Verify this.] □

As indicated above the notion of “basis for a topology” allows us to define topologies. However the following example shows that we must be careful.

2.2.7 Example. Let $X = \{a, b, c\}$ and $\mathcal{B} = \{\{a\}, \{c\}, \{a, b\}, \{b, c\}\}$. Then \mathcal{B} is not a basis for any topology on X . To see this, suppose that \mathcal{B} is a basis for a topology \mathcal{T} . Then \mathcal{T} consists of all unions of sets in \mathcal{B} ; that is,

$$\mathcal{T} = \{X, \emptyset, \{a\}, \{c\}, \{a, c\}, \{a, b\}, \{b, c\}\}.$$

(Once again we use the fact that \emptyset is an empty union of members of \mathcal{B} and so $\emptyset \in \mathcal{T}$.)

However, \mathcal{T} is not a topology since the set $\{b\} = \{a, b\} \cap \{b, c\}$ is not in \mathcal{T} and so \mathcal{T} does not have property (iii) of Definitions 1.1.1. This is a contradiction, and so our supposition is false. Thus \mathcal{B} is not a basis for any topology on X . □

Thus we are led to ask: if \mathcal{B} is a collection of subsets of X , under what conditions is \mathcal{B} a basis for a topology? This question is answered by Proposition 2.2.8.

2.2.8 Proposition. Let X be a non-empty set and let \mathcal{B} be a collection of subsets of X . Then \mathcal{B} is a basis for a topology on X if and only if \mathcal{B} has the following properties:

- (a) $X = \bigcup_{B \in \mathcal{B}} B$, and
- (b) for any $B_1, B_2 \in \mathcal{B}$, the set $B_1 \cap B_2$ is a union of members of \mathcal{B} .

Proof. If \mathcal{B} is a basis for a topology \mathcal{T} then \mathcal{T} must have the properties (i), (ii), and (iii) of Definitions 1.1.1. In particular X must be an open set and the intersection of any two open sets must be an open set. As the open sets are just the unions of members of \mathcal{B} , this implies that (a) and (b) above are true.

Conversely, assume that \mathcal{B} has properties (a) and (b) and let \mathcal{T} be the collection of all subsets of X which are unions of members of \mathcal{B} . We shall show that \mathcal{T} is a topology on X . (If so then \mathcal{B} is obviously a basis for this topology \mathcal{T} and the proposition is true.)

By (a), $X = \bigcup_{B \in \mathcal{B}} B$ and so $X \in \mathcal{T}$. Note that \emptyset is an empty union of members of \mathcal{B} and so $\emptyset \in \mathcal{T}$. So we see that \mathcal{T} does have property (i) of Definitions 1.1.1.

Now let $\{T_j\}$ be a family of members of \mathcal{T} . Then each T_j is a union of members of \mathcal{B} . Hence the union of all the T_j is also a union of members of \mathcal{B} and so is in \mathcal{T} . Thus \mathcal{T} also satisfies condition (ii) of Definitions 1.1.1.

Finally let C and D be in \mathcal{T} . We need to verify that $C \cap D \in \mathcal{T}$. But $C = \bigcup_{k \in K} B_k$, for some index set K and sets $B_k \in \mathcal{B}$. Also $D = \bigcup_{j \in J} B_j$, for some index set J and $B_j \in \mathcal{B}$. Therefore

$$C \cap D = \left(\bigcup_{k \in K} B_k \right) \cap \left(\bigcup_{j \in J} B_j \right) = \bigcup_{k \in K, j \in J} (B_k \cap B_j).$$

You should verify that the two expressions for $C \cap D$ are indeed equal!

In the finite case this involves statements like

$$(B_1 \cup B_2) \cap (B_3 \cup B_4) = (B_1 \cap B_3) \cup (B_1 \cap B_4) \cup (B_2 \cap B_3) \cup (B_2 \cap B_4).$$

By our assumption (b), each $B_k \cap B_j$ is a union of members of \mathcal{B} and so $C \cap D$ is a union of members of \mathcal{B} . Thus $C \cap D \in \mathcal{T}$. So \mathcal{T} has property (iii) of Definition 1.1.1. Hence \mathcal{T} is indeed a topology, and \mathcal{B} is a basis for this topology, as required. \square

Proposition 2.2.8 is a very useful result. It allows us to define topologies by simply writing down a basis. This is often easier than trying to describe all of the open sets.

We shall now use this Proposition to define a topology on the plane. This topology is known as the “euclidean topology”.

2.2.9 Example. Let \mathcal{B} be the collection of all “open rectangles”

$\{\langle x, y \rangle : \langle x, y \rangle \in \mathbb{R}^2, a < x < b, c < y < d\}$ in the plane which have each side parallel to the X - or Y -axis.

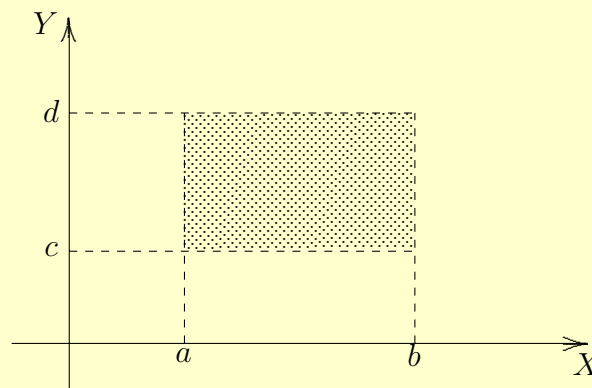

Then \mathcal{B} is a basis for a topology on the plane. This topology is called the euclidean topology.

Whenever we use the symbol \mathbb{R}^2 we mean the plane, and if we refer to \mathbb{R}^2 as a topological space without explicitly saying what the topology is, we mean the plane with the euclidean topology.

To see that \mathcal{B} is indeed a basis for a topology, observe that (i) the plane is the union of all of the open rectangles, and (ii) the intersection of any two rectangles is a rectangle. [By “rectangle” we mean one with sides parallel to the axes.] So the conditions of Proposition 2.2.8 are satisfied and hence \mathcal{B} is a basis for a topology. \square

2.2.10 Remark. By generalizing Example 2.2.9 we see how to put a topology on

$$\mathbb{R}^n = \{\langle x_1, x_2, \dots, x_n \rangle : x_i \in \mathbb{R}, i = 1, \dots, n\}, \quad \text{for each integer } n > 2.$$

We let \mathcal{B} be the collection of all subsets $\{\langle x_1, x_2, \dots, x_n \rangle \in \mathbb{R}^n : a_i < x_i < b_i, i = 1, 2, \dots, n\}$ of \mathbb{R}^n with sides parallel to the axes. This collection \mathcal{B} is a basis for the **euclidean topology** on \mathbb{R}^n . \square

Exercises 2.2

1. In this exercise you will prove that disc $\{\langle x, y \rangle : x^2 + y^2 < 1\}$ is an open subset of \mathbb{R}^2 , and then that every open disc in the plane is an open set.

(i) Let $\langle a, b \rangle$ be any point in the disc $D = \{\langle x, y \rangle : x^2 + y^2 < 1\}$. Put $r = \sqrt{a^2 + b^2}$. Let $R_{\langle a, b \rangle}$ be the open rectangle with vertices at the points $\langle a \pm \frac{1-r}{8}, b \pm \frac{1-r}{8} \rangle$. Verify that $R_{\langle a, b \rangle} \subset D$.

(ii) Using (i) show that

$$D = \bigcup_{\langle a, b \rangle \in D} R_{\langle a, b \rangle}.$$

(iii) Deduce from (ii) that D is an open set in \mathbb{R}^2 .

(iv) Show that every disc $\{\langle x, y \rangle : (x - a)^2 + (y - b)^2 < c^2, a, b, c \in \mathbb{R}\}$ is open in \mathbb{R}^2 .

2. In this exercise you will show that the collection of all open discs in \mathbb{R}^2 is a basis for a topology on \mathbb{R}^2 . [Later we shall see that this is the euclidean topology.]

(i) Let D_1 and D_2 be any open discs in \mathbb{R}^2 with $D_1 \cap D_2 \neq \emptyset$. If $\langle a, b \rangle$ is any point in $D_1 \cap D_2$, show that there exists an open disc $D_{\langle a, b \rangle}$ with centre $\langle a, b \rangle$ such that $D_{\langle a, b \rangle} \subset D_1 \cap D_2$. [Hint: draw a picture and use a method similar to that of Exercise 1 (i).]

(ii) Show that

$$D_1 \cap D_2 = \bigcup_{\langle a, b \rangle \in D_1 \cap D_2} D_{\langle a, b \rangle}.$$

(iii) Using (ii) and Proposition 2.2.8, prove that the collection of all open discs in \mathbb{R}^2 is a basis for a topology on \mathbb{R}^2 .

3. Let \mathcal{B} be the collection of all open intervals (a, b) in \mathbb{R} with $a < b$ and a and b rational numbers. Prove that \mathcal{B} is a basis for the euclidean topology on \mathbb{R} . [Compare this with Proposition 2.2.1 and Example 2.2.3 where a and b were not necessarily rational.]

[Hint: do not use Proposition 2.2.8 as this would show only that \mathcal{B} is a basis for some topology not necessarily a basis for the euclidean topology.]

4. A topological space (X, \mathcal{T}) is said to satisfy the **second axiom of countability** if there exists a basis \mathcal{B} for \mathcal{T} such that \mathcal{B} consists of only a countable number of sets.

(i) Using Exercise 3 above show that \mathbb{R} satisfies the second axiom of countability.

(ii) Prove that the discrete topology on an uncountable set does not satisfy the second axiom of countability.

[Hint. It is not enough to show that one particular basis is uncountable. You must prove that every basis for this topology is uncountable.]

(iii) Prove that \mathbb{R}^n satisfies the second axiom of countability, for each positive integer n .

(iv) Let (X, \mathcal{T}) be the set of all integers with the finite-closed topology. Does the space (X, \mathcal{T}) satisfy the second axiom of countability?

5. Prove the following statements.

(i) Let m and c be real numbers, with $m \neq 0$. Then the line $L = \{\langle x, y \rangle : y = mx + c\}$ is a closed subset of \mathbb{R}^2 .

(ii) Let \mathbb{S}^1 be the unit circle given by $\mathbb{S}^1 = \{\langle x, y \rangle \in \mathbb{R}^2 : x^2 + y^2 = 1\}$. Then \mathbb{S}^1 is a closed subset of \mathbb{R}^2 .

(iii) Let \mathbb{S}^n be the unit n -sphere given by

$$\mathbb{S}^n = \{\langle x_1, x_2, \dots, x_n, x_{n+1} \rangle \in \mathbb{R}^{n+1} : x_1^2 + x_2^2 + \dots + x_{n+1}^2 = 1\}.$$

Then \mathbb{S}^n is a closed subset of \mathbb{R}^{n+1} .

(iv) Let B^n be the closed unit n -ball given by

$$B^n = \{\langle x_1, x_2, \dots, x_n \rangle \in \mathbb{R}^n : x_1^2 + x_2^2 + \dots + x_n^2 \leq 1\}.$$

Then B^n is a closed subset of \mathbb{R}^n .

(v) The curve $C = \{\langle x, y \rangle \in \mathbb{R}^2 : xy = 1\}$ is a closed subset of \mathbb{R}^2 .

6. Let \mathcal{B}_1 be a basis for a topology \mathcal{T}_1 on a set X and \mathcal{B}_2 a basis for a topology \mathcal{T}_2 on a set Y . The set $X \times Y$ consists of all ordered pairs $\langle x, y \rangle$, $x \in X$ and $y \in Y$. Let \mathcal{B} be the collection of subsets of $X \times Y$ consisting of all the sets $B_1 \times B_2$ where $B_1 \in \mathcal{B}_1$ and $B_2 \in \mathcal{B}_2$. Prove that \mathcal{B} is a basis for a topology on $X \times Y$. The topology so defined is called the **product topology** on $X \times Y$.

[Hint. See Example 2.2.9.]

7. Using Exercise 3 above and Exercises 2.1 #8, prove that every open subset of \mathbb{R} is an F_σ -set and a G_δ -set.

2.3 Basis for a Given Topology

Proposition 2.2.8 told us under what conditions a collection \mathcal{B} of subsets of a set X is a basis for some topology on X . However sometimes we are given a topology \mathcal{T} on X and we want to know whether \mathcal{B} is a basis for this specific topology \mathcal{T} . To verify that \mathcal{B} is a basis for \mathcal{T} we could simply apply Definition 2.2.2 and show that every member of \mathcal{T} is a union of members of \mathcal{B} . However, Proposition 2.3.2 provides us with an alternative method.

But first we present an example which shows that there is a difference between saying that a collection \mathcal{B} of subsets of X is a basis for some topology, and saying that it is a basis for a given topology.

2.3.1 Example. Let \mathcal{B} be the collection of all half-open intervals of the form $(a, b]$, $a < b$, where $(a, b] = \{x : x \in \mathbb{R}, a < x \leq b\}$. Then \mathcal{B} is a basis for a topology on \mathbb{R} , since \mathbb{R} is the union of all members of \mathcal{B} and the intersection of any two half-open intervals is a half-open interval.

However, the topology \mathcal{T}_1 which has \mathcal{B} as its basis, is not the euclidean topology on \mathbb{R} . We can see this by observing that $(a, b]$ is an open set in \mathbb{R} with topology \mathcal{T}_1 , while $(a, b]$ is not an open set in \mathbb{R} with the euclidean topology. (See Exercises 2.1 #1.) So \mathcal{B} is a basis for some topology but not a basis for the euclidean topology on \mathbb{R} . \square

2.3.2 Proposition. Let (X, \mathcal{T}) be a topological space. A family \mathcal{B} of open subsets of X is a basis for \mathcal{T} if and only if for any point x belonging to any open set U , there is a $B \in \mathcal{B}$ such that $x \in B \subseteq U$.

Proof.

We are required to prove that

- (i) if \mathcal{B} is a basis for \mathcal{T} and $x \in U \in \mathcal{T}$, then there exists a $B \in \mathcal{B}$ such that $x \in B \subseteq U$,
and
(ii) if for each $U \in \mathcal{T}$ and $x \in U$ there exists a $B \in \mathcal{B}$ such that $x \in B \subseteq U$, then \mathcal{B} is a basis for \mathcal{T} .

Assume \mathcal{B} is a basis for \mathcal{T} and $x \in U \in \mathcal{T}$. As \mathcal{B} is a basis for \mathcal{T} , the open set U is a union of members of \mathcal{B} ; that is, $U = \bigcup_{j \in J} B_j$, where $B_j \in \mathcal{B}$, for each j in some index set J . But $x \in U$ implies $x \in B_j$, for some $j \in J$. Thus $x \in B_j \subseteq U$, as required.

Conversely, assume that for each $U \in \mathcal{T}$ and each $x \in U$, there exists a $B \in \mathcal{B}$ with $x \in B \subseteq U$. We have to show that every open set is a union of members of \mathcal{B} . So let V be any open set. Then for each $x \in V$, there is a $B_x \in \mathcal{B}$ such that $x \in B_x \subseteq V$. Clearly $V = \bigcup_{x \in V} B_x$. (Check this!) Thus V is a union of members of \mathcal{B} . \square

2.3.3 Proposition. Let \mathcal{B} be a basis for a topology \mathcal{T} on a set X . Then a subset U of X is open if and only if for each $x \in U$ there exists a $B \in \mathcal{B}$ such that $x \in B \subseteq U$.

Proof. Let U be any subset of X . Assume that for each $x \in U$, there exists a $B_x \in \mathcal{B}$ such that $x \in B_x \subseteq U$. Clearly $U = \bigcup_{x \in U} B_x$. So U is a union of open sets and hence is open, as required. The converse statement follows from Proposition 2.3.2. \square

Observe that the basis property described in Proposition 2.3.3 is precisely what we used in defining the euclidean topology on \mathbb{R} . We said that a subset U of \mathbb{R} is open if and only if for each $x \in U$, there exist a and b in \mathbb{R} with $a < b$, such that $x \in (a, b) \subseteq U$.

Warning. Make sure that you understand the difference between Proposition 2.2.8 and Proposition 2.3.2. Proposition 2.2.8 gives conditions for a family \mathcal{B} of subsets of a set X to be a basis for some topology on X . However, Proposition 2.3.2 gives conditions for a family \mathcal{B} of subsets of a topological space (X, \mathcal{T}) to be a basis for the given topology \mathcal{T} .

We have seen that a topology can have many different bases. The next proposition tells us when two bases \mathcal{B}_1 and \mathcal{B}_2 on the same set X define the same topology.

2.3.4 Proposition. Let \mathcal{B}_1 and \mathcal{B}_2 be bases for topologies \mathcal{T}_1 and \mathcal{T}_2 , respectively, on a non-empty set X . Then $\mathcal{T}_1 = \mathcal{T}_2$ if and only if

- (i) for each $B \in \mathcal{B}_1$ and each $x \in B$, there exists a $B' \in \mathcal{B}_2$ such that $x \in B' \subseteq B$, and
- (ii) for each $B \in \mathcal{B}_2$ and each $x \in B$, there exists a $B' \in \mathcal{B}_1$ such that $x \in B' \subseteq B$.

Proof.

We are required to show that \mathcal{B}_1 and \mathcal{B}_2 are bases for the same topology if and only if (i) and (ii) are true.

Firstly we assume that they are bases for the same topology, that is $\mathcal{T}_1 = \mathcal{T}_2$, and show that conditions (i) and (ii) hold.

Next we assume that (i) and (ii) hold and show that $\mathcal{T}_1 = \mathcal{T}_2$.

Firstly, assume that $\mathcal{T}_1 = \mathcal{T}_2$. Then (i) and (ii) are immediate consequences of Proposition 2.3.2.

Conversely, assume that \mathcal{B}_1 and \mathcal{B}_2 satisfy the conditions (i) and (ii). By Proposition 2.3.2, (i) implies that each $B \in \mathcal{B}_1$ is open in (X, \mathcal{T}_2) ; that is, $\mathcal{B}_1 \subseteq \mathcal{T}_2$. As every member of \mathcal{T}_1 is a union of members of \mathcal{T}_2 this implies $\mathcal{T}_1 \subseteq \mathcal{T}_2$. Similarly (ii) implies $\mathcal{T}_2 \subseteq \mathcal{T}_1$. Hence $\mathcal{T}_1 = \mathcal{T}_2$, as required. \square

2.3.5 Example. Show that the set \mathcal{B} of all “open equilateral triangles” with base parallel to the X -axis is a basis for the euclidean topology on \mathbb{R}^2 . (By an “open triangle” we mean that the boundary is not included.)

Outline Proof. (We give here only a pictorial argument. It is left to you to write a detailed proof.)

We are required to show that \mathcal{B} is a basis for the euclidean topology.

We shall apply Proposition 2.3.4, but first we need to show that \mathcal{B} is a basis for some topology on \mathbb{R}^2 .

To do this we show that \mathcal{B} satisfies the conditions of Proposition 2.2.8.

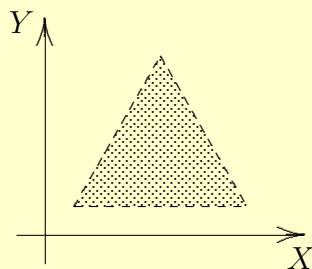

The first thing we observe is that \mathcal{B} is a basis for some topology because it satisfies the conditions of Proposition 2.2.8. (To see that \mathcal{B} satisfies Proposition 2.2.8, observe that \mathbb{R}^2 equals the union of all open equilateral triangles with base parallel to the X -axis, and that the intersection of two such triangles is another such triangle.)

Next we shall show that the conditions (i) and (ii) of Proposition 2.3.4 are satisfied.

Firstly we verify condition (i). Let R be an open rectangle with sides parallel to the axes and any x any point in R . We have to show that there is an open equilateral triangle T with base parallel to the X -axis such that $x \in T \subseteq R$. Pictorially this is easy to see.

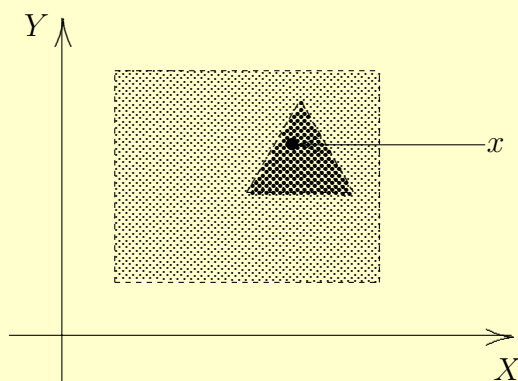

Finally we verify condition (ii) of Proposition 2.3.4. Let T' be an open equilateral triangle with base parallel to the X -axis and let y be any point in T' . Then there exists an open rectangle R' such that $y \in R' \subseteq T'$. Pictorially, this is again easy to see.

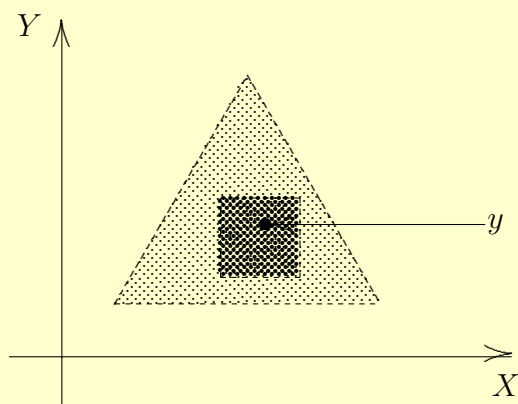

So the conditions of Proposition 2.3.4 are satisfied. Thus \mathcal{B} is indeed a basis for the euclidean topology on \mathbb{R}^2 . □

In Example 2.2.9 we defined a basis for the euclidean topology to be the collection of all “open rectangles” (with sides parallel to the axes). Example 2.3.5 shows that “open rectangles” can be replaced by “open equilateral triangles” (with base parallel to the X -axis) without changing the topology. In Exercises 2.3 #1 we see that the conditions above in brackets can be dropped without changing the topology. Also “open rectangles” can be replaced by “open discs”¹.

¹In fact, most books describe the euclidean topology on \mathbb{R}^2 in terms of open discs.

 Exercises 2.3

1. Determine whether or not each of the following collections is a basis for the euclidean topology on \mathbb{R}^2 :
 - (i) the collection of all “open” squares with sides parallel to the axes;
 - (ii) the collection of all “open” discs;
 - (iii) the collection of all “open” squares;
 - (iv) the collection of all “open” rectangles.
 - (v) the collection of all “open” triangles

2. (i) Let \mathcal{B} be a basis for a topology on a non-empty set X . If \mathcal{B}_1 is a collection of subsets of X such that $\mathcal{T} \supseteq \mathcal{B}_1 \supseteq \mathcal{B}$, prove that \mathcal{B}_1 is also a basis for \mathcal{T} .
 - (ii) Deduce from (i) that there exist an uncountable number of distinct bases for the euclidean topology on \mathbb{R} .

3. Let $\mathcal{B} = \{(a, b) : a, b \in \mathbb{R}, a < b\}$. As seen in Example 2.3.1, \mathcal{B} is a basis for a topology \mathcal{T} on \mathbb{R} and \mathcal{T} is not the euclidean topology on \mathbb{R} . Nevertheless, show that each interval (a, b) is open in $(\mathbb{R}, \mathcal{T})$.

- 4.* Let $C[0, 1]$ be the set of all continuous real-valued functions on $[0, 1]$.
 - (i) Show that the collection \mathcal{M} , where $\mathcal{M} = \{M(f, \varepsilon) : f \in C[0, 1] \text{ and } \varepsilon \text{ is a positive real number}\}$ and $M(f, \varepsilon) = \left\{g : g \in C[0, 1] \text{ and } \int_0^1 |f - g| < \varepsilon\right\}$, is a basis for a topology \mathcal{T}_1 on $C[0, 1]$.
 - (ii) Show that the collection \mathcal{U} , where $\mathcal{U} = \{U(f, \varepsilon) : f \in C[0, 1] \text{ and } \varepsilon \text{ is a positive real number}\}$ and $U(f, \varepsilon) = \{g : g \in C[0, 1] \text{ and } \sup_{x \in [0, 1]} |f(x) - g(x)| < \varepsilon\}$, is a basis for a topology \mathcal{T}_2 on $C[0, 1]$.
 - (iii) Prove that $\mathcal{T}_1 \neq \mathcal{T}_2$.

5. Let (X, \mathcal{T}) be a topological space. A non-empty collection \mathcal{S} of open subsets of X is said to be a **subbasis** for \mathcal{T} if the collection of all finite intersections of members of \mathcal{S} forms a basis for \mathcal{T} .
- (i) Prove that the collection of all open intervals of the form (a, ∞) or $(-\infty, b)$ is a subbasis for the euclidean topology on \mathbb{R} .
- (ii) Prove that $\mathcal{S} = \{\{a\}, \{a, c, d\}, \{b, c, d, e, f\}\}$ is a subbasis for the topology \mathcal{T}_1 of Example 1.1.2.
6. Let \mathcal{S} be a subbasis for a topology \mathcal{T} on the set \mathbb{R} . (See Exercise 5 above.) If all of the closed intervals $[a, b]$, with $a < b$, are in \mathcal{S} , prove that \mathcal{T} is the discrete topology.
7. Let X be a non-empty set and \mathcal{S} the collection of all sets $X \setminus \{x\}$, $x \in X$. Prove \mathcal{S} is a subbasis for the finite-closed topology on X .
8. Let X be any infinite set and \mathcal{T} the discrete topology on X . Find a subbasis \mathcal{S} for \mathcal{T} such that \mathcal{S} does not contain any singleton sets.
9. Let \mathcal{S} be the collection of all straight lines in the plane \mathbb{R}^2 . If \mathcal{S} is a subbasis for a topology \mathcal{T} on the set \mathbb{R}^2 , what is the topology?
10. Let \mathcal{S} be the collection of all straight lines in the plane which are parallel to the X -axis. If \mathcal{S} is a subbasis for a topology \mathcal{T} on \mathbb{R}^2 , describe the open sets in $(\mathbb{R}^2, \mathcal{T})$.
11. Let \mathcal{S} be the collection of all circles in the plane. If \mathcal{S} is a subbasis for a topology \mathcal{T} on \mathbb{R}^2 , describe the open sets in $(\mathbb{R}^2, \mathcal{T})$.
12. Let \mathcal{S} be the collection of all circles in the plane which have their centres on the X -axis. If \mathcal{S} is a subbasis for a topology \mathcal{T} on \mathbb{R}^2 , describe the open sets in $(\mathbb{R}^2, \mathcal{T})$.

2.4 Postscript

In this chapter we have defined a very important topological space – \mathbb{R} , the set of all real numbers with the euclidean topology, and spent some time analyzing it. We observed that, in this topology, open intervals are indeed open sets (and closed intervals are closed sets). However, not all open sets are open intervals. Nevertheless, every open set in \mathbb{R} is a union of open intervals. This led us to introduce the notion of “basis for a topology” and to establish that the collection of all open intervals is a basis for the euclidean topology on \mathbb{R} .

In the introduction to Chapter 1 we described a mathematical proof as a watertight argument and underlined the importance of writing proofs. In this chapter we were introduced to proof by contradiction in Remarks 2.1.2 (v) with another example in Example 2.2.7. Proving “necessary and sufficient” conditions, that is, “if and only if” conditions, was explained in Proposition 2.2.1, with further examples in Propositions 2.2.8, 2.3.2, 2.3.3, and 2.3.4.

Bases for topologies is a significant topic in its own right. We saw, for example, that the collection of all singletons is a basis for the discrete topology. Proposition 2.2.8 gives necessary and sufficient conditions for a collection of subsets of a set X to be a basis for some topology on X . This was contrasted with Proposition 2.3.2 which gives necessary and sufficient conditions for a collection of subsets of X to be a basis for the given topology on X . It was noted that two different collections \mathcal{B}_1 and \mathcal{B}_2 can be bases for the same topology. Necessary and sufficient conditions for this are given by Proposition 2.3.4.

We defined the euclidean topology on \mathbb{R}^n , for n any positive integer. We saw that the family of all open discs is a basis for \mathbb{R}^2 , as is the family of all open squares, or the family of all open rectangles.

The exercises introduced three interesting ideas. Exercises 2.1 #8 covered the notions of F_σ -set and G_δ -set which are important in measure theory. Exercises 2.3 #4 introduced the space of continuous real-valued functions. Such spaces are called function spaces which are the central objects of study in functional analysis. Functional analysis is a blend of (classical) analysis and topology, and was for some time called modern analysis, cf. Simmons [169]. Finally, Exercises 2.3 #5–12 dealt with the notion of subbasis.

Chapter 3

Limit Points

Introduction

On the real number line we have a notion of “closeness”. For example each point in the sequence $.1, .01, .001, .0001, .00001, \dots$ is closer to 0 than the previous one. Indeed, in some sense, 0 is a limit point of this sequence. So the interval $(0, 1]$ is not closed, as it does not contain the limit point 0. In a general topological space we do not have a “distance function”, so we must proceed differently. We shall define the notion of limit point without resorting to distances. Even with our new definition of limit point, the point 0 will still be a limit point of $(0, 1]$. The introduction of the notion of limit point will lead us to a much better understanding of the notion of closed set.

Another very important topological concept we shall introduce in this chapter is that of connectedness. Consider the topological space \mathbb{R} . While the sets $[0, 1] \cup [2, 3]$ and $[4, 6]$ could both be described as having length 2, it is clear that they are different types of sets ... the first consists of two disjoint pieces and the second of just one piece. The difference between the two is “topological” and will be exposed using the notion of connectedness.

3.1 Limit Points and Closure

If (X, \mathcal{T}) is a topological space then it is usual to refer to the elements of the set X as **points**.

3.1.1 Definition. Let A be a subset of a topological space (X, \mathcal{T}) . A point $x \in X$ is said to be a **limit point** (or **accumulation point** or **cluster point**) of A if every open set, U , containing x contains a point of A different from x .

3.1.2 Example. Consider the topological space (X, \mathcal{T}) where the set $X = \{a, b, c, d, e\}$, the topology $\mathcal{T} = \{X, \emptyset, \{a\}, \{c, d\}, \{a, c, d\}, \{b, c, d, e\}\}$, and $A = \{a, b, c\}$. Then b, d , and e are limit points of A but a and c are not limit points of A .

Proof.

The point a is a limit point of A if and only if every open set containing a contains another point of the set A .

So to show that a is **not** a limit point of A , it suffices to find even one open set which contains a but contains no other point of A .

The set $\{a\}$ is open and contains no other point of A . So a is not a limit point of A .

The set $\{c, d\}$ is an open set containing c but no other point of A . So c is not a limit point of A .

To show that b is a limit point of A , we have to show that every open set containing b contains a point of A other than b .

We shall show this is the case by writing down **all** of the open sets containing b and verifying that each contains a point of A other than b .

The only open sets containing b are X and $\{b, c, d, e\}$ and both contain another element of A , namely c . So b is a limit point of A .

The point d is a limit point of A , even though it is not in A . This is so since every open set containing d contains a point of A . Similarly e is a limit point of A even though it is not in A . \square

3.1.3 Example. Let (X, \mathcal{T}) be a discrete space and A a subset of X . Then A has no limit points, since for each $x \in X$, $\{x\}$ is an open set containing no point of A different from x . \square

3.1.4 Example. Consider the subset $A = [a, b)$ of \mathbb{R} . Then it is easily verified that every element in $[a, b)$ is a limit point of A . The point b is also a limit point of A . \square

3.1.5 Example. Let (X, \mathcal{T}) be an indiscrete space and A a subset of X with at least two elements. Then it is readily seen that every point of X is a limit point of A . (Why did we insist that A have at least two points?) \square

The next proposition provides a useful way of testing whether a set is closed or not.

3.1.6 Proposition. Let A be a subset of a topological space (X, \mathcal{T}) . Then A is closed in (X, \mathcal{T}) if and only if A contains all of its limit points.

Proof.

We are required to prove that A is closed in (X, \mathcal{T}) if and only if A contains all of its limit points; that is, we have to show that

- (i) if A is a closed set, then it contains all of its limit points, and
- (ii) if A contains all of its limit points, then it is a closed set.

Assume that A is closed in (X, \mathcal{T}) . Suppose that p is a limit point of A which belongs to $X \setminus A$. Then $X \setminus A$ is an open set containing the limit point p of A . Therefore $X \setminus A$ contains an element of A . This is clearly false and so we have a contradiction to our supposition. Therefore every limit point of A must belong to A .

Conversely, assume that A contains all of its limit points. For each $z \in X \setminus A$, our assumption implies that there exists an open set $U_z \ni z$ such that $U_z \cap A = \emptyset$; that is, $U_z \subseteq X \setminus A$. Therefore $X \setminus A = \bigcup_{z \in X \setminus A} U_z$. (Check this!) So $X \setminus A$ is a union of open sets and hence is open. Consequently its complement, A , is closed. \square

3.1.7 Example. As applications of Proposition 3.1.6 we have the following:

- (i) the set $[a, b)$ is not closed in \mathbb{R} , since b is a limit point and $b \notin [a, b)$;
- (ii) the set $[a, b]$ is closed in \mathbb{R} , since all the limit points of $[a, b]$ (namely all the elements of $[a, b]$) are in $[a, b]$;
- (iii) (a, b) is not a closed subset of \mathbb{R} , since it does not contain the limit point a ;
- (iv) $[a, \infty)$ is a closed subset of \mathbb{R} . □

3.1.8 Proposition. Let A be a subset of a topological space (X, \mathcal{T}) and A' the set of all limit points of A . Then $A \cup A'$ is a closed set.

Proof. From Proposition 3.1.6 it suffices to show that the set $A \cup A'$ contains all of its limit points or equivalently that no element of $X \setminus (A \cup A')$ is a limit point of $A \cup A'$.

Let $p \in X \setminus (A \cup A')$. As $p \notin A'$, there exists an open set U containing p with $U \cap A = \{p\}$ or \emptyset . But $p \notin A$, so $U \cap A = \emptyset$. We claim also that $U \cap A' = \emptyset$. For if $x \in U$ then as U is an open set and $U \cap A = \emptyset$, $x \notin A'$. Thus $U \cap A' = \emptyset$. That is, $U \cap (A \cup A') = \emptyset$, and $p \in U$. This implies p is not a limit point of $A \cup A'$ and so $A \cup A'$ is a closed set. □

3.1.9 Definition. Let A be a subset of a topological space (X, \mathcal{T}) . Then the set $A \cup A'$ consisting of A and all its limit points is called the **closure of A** and is denoted by \bar{A} .

3.1.10 Remark. It is clear from Proposition 3.1.8 that \bar{A} is a closed set. By Proposition 3.1.6 and Exercises 3.1 #5 (i), every closed set containing A must also contain the set A' . So $A \cup A' = \bar{A}$ is the smallest closed set containing A . This implies that \bar{A} is the intersection of all closed sets containing A . □

3.1.11 Example. Let $X = \{a, b, c, d, e\}$ and

$$\mathcal{T} = \{X, \emptyset, \{a\}, \{c, d\}, \{a, c, d\}, \{b, c, d, e\}\}.$$

Show that $\overline{\{b\}} = \{b, e\}$, $\overline{\{a, c\}} = X$, and $\overline{\{b, d\}} = \{b, c, d, e\}$.

Proof.

To find the closure of a particular set, we shall find all the closed sets containing that set and then select the smallest. We therefore begin by writing down all of the closed sets – these are simply the complements of all the open sets.

The closed sets are $\emptyset, X, \{b, c, d, e\}, \{a, b, e\}, \{b, e\}$ and $\{a\}$. So the smallest closed set containing $\{b\}$ is $\{b, e\}$; that is, $\overline{\{b\}} = \{b, e\}$. Similarly $\overline{\{a, c\}} = X$, and $\overline{\{b, d\}} = \{b, c, d, e\}$. \square

3.1.12 Example. Let \mathbb{Q} be the subset of \mathbb{R} consisting of all the rational numbers. Prove that $\overline{\mathbb{Q}} = \mathbb{R}$.

Proof. Suppose $\overline{\mathbb{Q}} \neq \mathbb{R}$. Then there exists an $x \in \mathbb{R} \setminus \overline{\mathbb{Q}}$. As $\mathbb{R} \setminus \overline{\mathbb{Q}}$ is open in \mathbb{R} , there exist a, b with $a < b$ such that $x \in (a, b) \subseteq \mathbb{R} \setminus \overline{\mathbb{Q}}$. But in every interval (a, b) there is a rational number q ; that is, $q \in (a, b)$. So $q \in \mathbb{R} \setminus \overline{\mathbb{Q}}$ which implies $q \in \mathbb{R} \setminus \mathbb{Q}$. This is a contradiction, as $q \in \mathbb{Q}$. Hence $\overline{\mathbb{Q}} = \mathbb{R}$. \square

3.1.13 Definition. Let A be a subset of a topological space (X, \mathcal{T}) . Then A is said to be **dense** in X or **everywhere dense** in X if $\overline{A} = X$.

We can now restate Example 3.1.12 as: \mathbb{Q} is a dense subset of \mathbb{R} .

Note that in Example 3.1.11 we saw that $\{a, c\}$ is dense in X .

3.1.14 Example. Let (X, \mathcal{T}) be a discrete space. Then every subset of X is closed (since its complement is open). Therefore the only dense subset of X is X itself, since each subset of X is its own closure. \square

3.1.15 Proposition. Let A be a subset of a topological space (X, \mathcal{T}) . Then A is dense in X if and only if every non-empty open subset of X intersects A non-trivially (that is, if $U \in \mathcal{T}$ and $U \neq \emptyset$ then $A \cap U \neq \emptyset$.)

Proof. Assume, firstly that every non-empty open set intersects A non-trivially. If $A = X$, then clearly A is dense in X . If $A \neq X$, let $x \in X \setminus A$. If $U \in \mathcal{T}$ and $x \in U$ then $U \cap A \neq \emptyset$. So x is a limit point of A . As x is an arbitrary point in $X \setminus A$, every point of $X \setminus A$ is a limit point of A . So $A' \supseteq X \setminus A$ and then, by Definition 3.1.9, $\overline{A} = A' \cup A = X$; that is, A is dense in X .

Conversely, assume A is dense in X . Let U be any non-empty open subset of X . Suppose $U \cap A = \emptyset$. Then if $x \in U$, $x \notin A$ and x is not a limit point of A , since U is an open set containing x which does not contain any element of A . This is a contradiction since, as A is dense in X , every element of $X \setminus A$ is a limit point of A . So our supposition is false and $U \cap A \neq \emptyset$, as required. □

Exercises 3.1

1. (a) In Example 1.1.2, find all the limit points of the following sets:
 - (i) $\{a\}$,
 - (ii) $\{b, c\}$,
 - (iii) $\{a, c, d\}$,
 - (iv) $\{b, d, e, f\}$.

(b) Hence, find the closure of each of the above sets.

(c) Now find the closure of each of the above sets using the method of Example 3.1.11.
2. Let $(\mathbb{Z}, \mathcal{T})$ be the set of integers with the finite-closed topology. List the set of limit points of the following sets:
 - (i) $A = \{1, 2, 3, \dots, 10\}$,
 - (ii) The set, E , consisting of all even integers.

3. Find all the limit points of the open interval (a, b) in \mathbb{R} , where $a < b$.
4. (a) What is the closure in \mathbb{R} of each of the following sets?
- (i) $\{1, \frac{1}{2}, \frac{1}{3}, \frac{1}{4}, \dots, \frac{1}{n}, \dots\}$,
 - (ii) the set \mathbb{Z} of all integers,
 - (iii) the set \mathbb{P} of all irrational numbers.
- (b) Let S be a subset of \mathbb{R} and $a \in \mathbb{R}$. Prove that $a \in \overline{S}$ if and only if for each positive integer n , there exists an $x_n \in S$ such that $|x_n - a| < \frac{1}{n}$.
5. Let S and T be non-empty subsets of a topological space (X, \mathcal{T}) with $S \subseteq T$.
- (i) If p is a limit point of the set S , verify that p is also a limit point of the set T .
 - (ii) Deduce from (i) that $\overline{S} \subseteq \overline{T}$.
 - (iii) Hence show that if S is dense in X , then T is dense in X .
 - (iv) Using (iii) show that \mathbb{R} has an uncountable number of distinct dense subsets.
 - (v)* Again using (iii), prove that \mathbb{R} has an uncountable number of distinct countable dense subsets and $2^{\mathfrak{c}}$ distinct uncountable dense subsets.

3.2 Neighbourhoods

3.2.1 Definition. Let (X, \mathcal{T}) be a topological space, N a subset of X and p a point in X . Then N is said to be a **neighbourhood** of the point p if there exists an open set U such that $p \in U \subseteq N$.

3.2.2 Example. The closed interval $[0, 1]$ in \mathbb{R} is a neighbourhood of the point $\frac{1}{2}$, since $\frac{1}{2} \in (\frac{1}{4}, \frac{3}{4}) \subseteq [0, 1]$. □

3.2.3 Example. The interval $(0, 1]$ in \mathbb{R} is a neighbourhood of the point $\frac{1}{4}$, as $\frac{1}{4} \in (0, \frac{1}{2}) \subseteq (0, 1]$. But $(0, 1]$ is not a neighbourhood of the point 1. (Prove this.) □

3.2.4 Example. If (X, \mathcal{T}) is any topological space and $U \in \mathcal{T}$, then from Definition 3.2.1, it follows that U is a neighbourhood of every point $p \in U$. So, for example, every open interval (a, b) in \mathbb{R} is a neighbourhood of every point that it contains. \square

3.2.5 Example. Let (X, \mathcal{T}) be a topological space, and N a neighbourhood of a point p . If S is any subset of X such that $N \subseteq S$, then S is a neighbourhood of p . \square

The next proposition is easily verified, so its proof is left to the reader.

3.2.6 Proposition. Let A be a subset of a topological space (X, \mathcal{T}) . A point $x \in X$ is a limit point of A if and only if every neighbourhood of x contains a point of A different from x . \square

As a set is closed if and only if it contains all its limit points we deduce the following:

3.2.7 Corollary. Let A be a subset of a topological space (X, \mathcal{T}) . Then the set A is closed if and only if for each $x \in X \setminus A$ there is a neighbourhood N of x such that $N \subseteq X \setminus A$. \square

3.2.8 Corollary. Let U be a subset of a topological space (X, \mathcal{T}) . Then $U \in \mathcal{T}$ if and only if for each $x \in U$ there exists a neighbourhood N of x such that $N \subseteq U$. \square

The next corollary is readily deduced from Corollary 3.2.8.

3.2.9 Corollary. Let U be a subset of a topological space (X, \mathcal{T}) . Then $U \in \mathcal{T}$ if and only if for each $x \in U$ there exists a $V \in \mathcal{T}$ such that $x \in V \subseteq U$. \square

Corollary 3.2.9 provides a useful test of whether a set is open or not. It says that a set is open if and only if it contains an open set about each of its points.

Exercises 3.2

1. Let A be a subset of a topological space (X, \mathcal{T}) . Prove that A is dense in X if and only if every neighbourhood of each point in $X \setminus A$ intersects A non-trivially.
2. (i) Let A and B be subsets of a topological space (X, \mathcal{T}) . Prove carefully that

$$\overline{A \cap B} \subseteq \overline{A} \cap \overline{B}.$$

- (ii) Construct an example in which

$$\overline{A \cap B} \neq \overline{A} \cap \overline{B}.$$

3. Let (X, \mathcal{T}) be a topological space. Prove that \mathcal{T} is the finite-closed topology on X if and only if (i) (X, \mathcal{T}) is a T_1 -space, and (ii) every infinite subset of X is dense in X .
4. A topological space (X, \mathcal{T}) is said to be **separable** if it has a dense subset which is countable. Determine which of the following spaces are separable:
 - (i) the set \mathbb{R} with the usual topology;
 - (ii) a countable set with the discrete topology;
 - (iii) a countable set with the finite-closed topology;
 - (iv) (X, \mathcal{T}) where X is finite;
 - (v) (X, \mathcal{T}) where \mathcal{T} is finite;
 - (vi) an uncountable set with the discrete topology;
 - (vii) an uncountable set with the finite-closed topology;
 - (viii) a space (X, \mathcal{T}) satisfying the second axiom of countability.

5. Let (X, \mathcal{T}) be any topological space and A any subset of X . The largest open set contained in A is called the **interior of A** and is denoted by $\text{Int}(A)$. [It is the union of all open sets in X which lie wholly in A .]
- (i) Prove that in \mathbb{R} , $\text{Int}([0, 1]) = (0, 1)$.
 - (ii) Prove that in \mathbb{R} , $\text{Int}((3, 4)) = (3, 4)$.
 - (iii) Show that if A is open in (X, \mathcal{T}) then $\text{Int}(A) = A$.
 - (iv) Verify that in \mathbb{R} , $\text{Int}(\{3\}) = \emptyset$.
 - (v) Show that if (X, \mathcal{T}) is an indiscrete space then, for all proper subsets A of X , $\text{Int}(A) = \emptyset$.
 - (vi) Show that for every countable subset A of \mathbb{R} , $\text{Int}(A) = \emptyset$.
6. Show that if A is any subset of a topological space (X, \mathcal{T}) , then $\text{Int}(A) = X \setminus \overline{(X \setminus A)}$. (See Exercise 5 above for the definition of Int .)
7. Using Exercise 6 above, verify that A is dense in (X, \mathcal{T}) if and only if $\text{Int}(X \setminus A) = \emptyset$.
8. Using the definition of Int in Exercise 5 above, determine which of the following statements are true for arbitrary subsets A_1 and A_2 of a topological space (X, \mathcal{T}) ?
- (i) $\text{Int}(A_1 \cap A_2) = \text{Int}(A_1) \cap \text{Int}(A_2)$,
 - (ii) $\text{Int}(A_1 \cup A_2) = \text{Int}(A_1) \cup \text{Int}(A_2)$,
 - (iii) $\overline{A_1 \cup A_2} = \overline{A_1} \cup \overline{A_2}$.
- (If your answer to any part is “true” you must write a proof. If your answer is “false” you must give a concrete counterexample.)
- 9.* Let S be a dense subset of a topological space (X, \mathcal{T}) . Prove that for every open subset U of X , $\overline{S \cap U} = \overline{U}$.
10. Let S and T be dense subsets of a space (X, \mathcal{T}) . If T is also open, deduce from Exercise 9 above that $S \cap T$ is dense in X .

11. Let $\mathcal{B} = \{[a, b) : a \in \mathbb{R}, b \in \mathbb{Q}, a < b\}$. Prove each of the following statements.
- (i) \mathcal{B} is a basis for a topology \mathcal{T}_1 on \mathbb{R} . (The space $(\mathbb{R}, \mathcal{T}_1)$ is called the **Sorgenfrey line**.)
 - (ii) If \mathcal{T} is the Euclidean topology on \mathbb{R} , then $\mathcal{T}_1 \supset \mathcal{T}$.
 - (iii) For all $a, b \in \mathbb{R}$ with $a < b$, $[a, b)$ is a clopen set in $(\mathbb{R}, \mathcal{T}_1)$.
 - (iv) The Sorgenfrey line is a separable space.
 - (v)* The Sorgenfrey line does not satisfy the second axiom of countability.

3.3 Connectedness

3.3.1 Remark. We record here some definitions and facts you should already know. Let S be any set of real numbers. If there is an element b in S such that $x \leq b$, for all $x \in S$, then b is said to be **the greatest element** of S . Similarly if S contains an element a such that $a \leq x$, for all $x \in S$, then a is called **the least element** of S . A set S of real numbers is said to be **bounded above** if there exists a real number c such that $x \leq c$, for all $x \in S$, and c is called an **upper bound** for S . Similarly the terms “**bounded below**” and “**lower bound**” are defined. A set which is bounded above and bounded below is said to be **bounded**. □

Least Upper Bound Axiom: Let S be a non-empty set of real numbers. If S is bounded above, then it has a least upper bound. □

The least upper bound, also called **the supremum**, of S may or may not belong to the set S . Indeed, the supremum of S is an element of S if and only if S has a greatest element. For example, the supremum of the open interval $S = (1, 2)$ is 2 but $2 \notin (1, 2)$, while the supremum of $[3, 4]$ is 4 which does lie in $[3, 4]$ and 4 is the greatest element of $[3, 4]$. Any set of real numbers which is bounded below has a **greatest lower bound** which is also called the **infimum**.

3.3.2 Lemma. Let S be a subset of \mathbb{R} which is bounded above and let p be the supremum of S . If S is a closed subset of \mathbb{R} , then $p \in S$.

Proof. Suppose $p \in \mathbb{R} \setminus S$. As $\mathbb{R} \setminus S$ is open there exist real numbers a and b with $a < b$ such that $p \in (a, b) \subseteq \mathbb{R} \setminus S$. As p is the least upper bound for S and $a < p$, it is clear that there exists an $x \in S$ such that $a < x$. Also $x < p < b$, and so $x \in (a, b) \subseteq \mathbb{R} \setminus S$. But this is a contradiction, since $x \in S$. Hence our supposition is false and $p \in S$. \square

3.3.3 Proposition. Let T be a clopen subset of \mathbb{R} . Then either $T = \mathbb{R}$ or $T = \emptyset$.

Proof. Suppose $T \neq \mathbb{R}$ and $T \neq \emptyset$. Then there exists an element $x \in T$ and an element $z \in \mathbb{R} \setminus T$. Without loss of generality, assume $x < z$. Put $S = T \cap [x, z]$. Then S , being the intersection of two closed sets, is closed. It is also bounded above, since z is obviously an upper bound. Let p be the supremum of S . By Lemma 3.3.2, $p \in S$. Since $p \in [x, z]$, $p \leq z$. As $z \in \mathbb{R} \setminus S$, $p \neq z$ and so $p < z$.

Now T is also an open set and $p \in T$. So there exist a and b in \mathbb{R} with $a < b$ such that $p \in (a, b) \subseteq T$. Let t be such that $p < t < \min(b, z)$, where $\min(b, z)$ denotes the smaller of b and z . So $t \in T$ and $t \in [p, z]$. Thus $t \in T \cap [x, z] = S$. This is a contradiction since $t > p$ and p is the supremum of S . Hence our supposition is false and consequently $T = \mathbb{R}$ or $T = \emptyset$. \square

3.3.4 Definition. Let (X, \mathcal{T}) be a topological space. Then it is said to be **connected** if the only clopen subsets of X are X and \emptyset .

So restating Proposition 3.3.3 we obtain:

3.3.5 Proposition. The topological space \mathbb{R} is connected. \square

3.3.6 Example. If (X, \mathcal{T}) is any discrete space with more than one element, then (X, \mathcal{T}) is not connected as each singleton set is clopen. \square

3.3.7 Example. If (X, \mathcal{T}) is any indiscrete space, then it is connected as the only clopen sets are X and \emptyset . (Indeed the only open sets are X and \emptyset .) \square

3.3.8 Example. If $X = \{a, b, c, d, e\}$ and

$$\mathcal{T} = \{X, \emptyset, \{a\}, \{c, d\}, \{a, c, d\}, \{b, c, d, e\}\},$$

then (X, \mathcal{T}) is not connected as $\{b, c, d, e\}$ is a clopen subset. \square

3.3.9 Remark. From Definition 3.3.4 it follows that a topological space (X, \mathcal{T}) is not connected (that is, it is **disconnected**) if and only if there are non-empty open sets A and B such that $A \cap B = \emptyset$ and $A \cup B = X$.¹ (See Exercises 3.3 #3.)

We conclude this section by recording that \mathbb{R}^2 (and indeed, \mathbb{R}^n , for each $n \geq 1$) is a connected space. However the proof is delayed to Chapter 5.

Connectedness is a very important property about which we shall say a lot more.

Exercises 3.3

1. Let S be a set of real numbers and $T = \{x : -x \in S\}$.
 - (a) Prove that the real number a is the infimum of S if and only if $-a$ is the supremum of T .
 - (b) Using (a) and the Least Upper Bound Axiom prove that every non-empty set of real numbers which is bounded below has a greatest lower bound.

¹Most books use this property to define connectedness.

2. For each of the following sets of real numbers find the greatest element and the least upper bound, if they exist.
 - (i) $S = \mathbb{R}$.
 - (ii) $S = \mathbb{Z} =$ the set of all integers.
 - (iii) $S = [9, 10)$.
 - (iv) $S =$ the set of all real numbers of the form $1 - \frac{3}{n^2}$, where n is a positive integer.
 - (v) $S = (-\infty, 3]$.
3. Let (X, \mathcal{T}) be any topological space. Prove that (X, \mathcal{T}) is not connected if and only if it has proper non-empty disjoint open subsets A and B such that $A \cup B = X$.
4. Is the space (X, \mathcal{T}) of Example 1.1.2 connected?
5. Let (X, \mathcal{T}) be any infinite set with the finite-closed topology. Is (X, \mathcal{T}) connected?
6. Let (X, \mathcal{T}) be an infinite set with the countable-closed topology. Is (X, \mathcal{T}) connected?
7. Which of the topological spaces of Exercises 1.1 #9 are connected?

3.4 Postscript

In this chapter we have introduced the notion of limit point and shown that a set is closed if and only if it contains all its limit points. Proposition 3.1.8 then tells us that any set A has a smallest closed set \bar{A} which contains it. The set \bar{A} is called the closure of A .

A subset A of a topological space (X, \mathcal{T}) is said to be dense in X if $\bar{A} = X$. We saw that \mathbb{Q} is dense in \mathbb{R} and the set \mathbb{P} of all irrational numbers is also dense in \mathbb{R} . We introduced the notion of neighbourhood of a point and the notion of connected topological space. We proved an important result, namely that \mathbb{R} is connected. We shall have much more to say about connectedness later.

In the exercises we introduced the notion of interior of a set, this being complementary to that of closure of a set.

Chapter 4

Homeomorphisms

Introduction

In each branch of mathematics it is essential to recognize when two structures are equivalent. For example two sets are equivalent, as far as set theory is concerned, if there exists a bijective function which maps one set onto the other. Two groups are equivalent, known as isomorphic, if there exists a homomorphism of one to the other which is one-to-one and onto. Two topological spaces are equivalent, known as homeomorphic, if there exists a homeomorphism of one onto the other.

4.1 Subspaces

4.1.1 Definition. Let Y be a non-empty subset of a topological space (X, \mathcal{T}) . The collection $\mathcal{T}_Y = \{O \cap Y : O \in \mathcal{T}\}$ of subsets of Y is a topology on Y called the **subspace topology** (or the **relative topology** or the **induced topology** or the **topology induced on Y by \mathcal{T}**). The topological space (Y, \mathcal{T}_Y) is said to be a **subspace** of (X, \mathcal{T}) .

Of course you should check that \mathcal{T}_Y is indeed a topology on Y .

4.1.2 Example. Let $X = \{a, b, c, d, e, f, \}$,

$$\mathcal{T} = \{X, \emptyset, \{a\}, \{c, d\}, \{a, c, d\}, \{b, c, d, e, f\}\}$$

and $Y = \{b, c, e\}$. Then the subspace topology on Y is

$$\mathcal{T}_Y = \{Y, \emptyset, \{c\}\}.$$

□

4.1.3 Example. Let $X = \{a, b, c, d, e\}$,

$$\mathcal{T} = \{X, \emptyset, \{a\}, \{c, d\}, \{a, c, d\}, \{b, c, d, e\}\},$$

and $Y = \{a, d, e\}$. Then the induced topology on Y is

$$\mathcal{T}_Y = \{Y, \emptyset, \{a\}, \{d\}, \{a, d\}, \{d, e\}\}.$$

□

4.1.4 Example. Let \mathcal{B} be a basis for the topology \mathcal{T} on X and let Y be a subset of X . Then it is not hard to show that the collection $\mathcal{B}_Y = \{B \cap Y : B \in \mathcal{B}\}$ is a basis for the subspace topology \mathcal{T}_Y on Y . [Exercise: verify this.]

So let us consider the subset $(1, 2)$ of \mathbb{R} . A basis for the induced topology on $(1, 2)$ is the collection $\{(a, b) \cap (1, 2) : a, b \in \mathbb{R}, a < b\}$; that is, $\{(a, b) : a, b \in \mathbb{R}, 1 \leq a < b \leq 2\}$ is a basis for the induced topology on $(1, 2)$. □

4.1.5 Example. Consider the subset $[1, 2]$ of \mathbb{R} . A basis for the subspace topology \mathcal{T} on $[1, 2]$ is

$$\{(a, b) \cap [1, 2] : a, b \in \mathbb{R}, a < b\};$$

that is,

$$\{(a, b) : 1 \leq a < b \leq 2\} \cup \{[1, b) : 1 < b \leq 2\} \cup \{(a, 2] : 1 \leq a < 2\} \cup \{[1, 2]\}$$

is a basis for \mathcal{T} .

But here we see some surprising things happening; e.g. $[1, 1\frac{1}{2})$ is certainly not an open set in \mathbb{R} , but $[1, 1\frac{1}{2}) = (0, 1\frac{1}{2}) \cap [1, 2]$, $[1, 1\frac{1}{2})$ is an open set in the subspace $[1, 2]$.

Also $(1, 2]$ is not open in \mathbb{R} but is open in $[1, 2]$. Even $[1, 2]$ is not open in \mathbb{R} , but is an open set in $[1, 2]$.

So whenever we speak of a set being open we must make perfectly clear in what space or what topology it is an open set. □

4.1.6 Example. Let \mathbb{Z} be the subset of \mathbb{R} consisting of all the integers. Prove that the topology induced on \mathbb{Z} by the euclidean topology on \mathbb{R} is the discrete topology.

Proof.

To prove that the induced topology, $\tau_{\mathbb{Z}}$, on \mathbb{Z} is discrete, it suffices, by Proposition 1.1.9, to show that every singleton set in \mathbb{Z} is open in $\tau_{\mathbb{Z}}$; that is, if $n \in \mathbb{Z}$ then $\{n\} \in \tau_{\mathbb{Z}}$

Let $n \in \mathbb{Z}$. Then $\{n\} = (n - 1, n + 1) \cap \mathbb{Z}$. But $(n - 1, n + 1)$ is open in \mathbb{R} and therefore $\{n\}$ is open in the induced topology on \mathbb{Z} . Thus every singleton set in \mathbb{Z} is open in the induced topology on \mathbb{Z} . So the induced topology is discrete. \square

Notation. Whenever we refer to

\mathbb{Q} = the set of all rational numbers,

\mathbb{Z} = the set of all integers,

\mathbb{N} = the set of all positive integers,

\mathbb{P} = the set of all irrational numbers,

(a, b) , $[a, b]$, $[a, b)$, $(-\infty, a)$, $(-\infty, a]$, (a, ∞) , or $[a, \infty)$

as topological spaces without explicitly saying what the topology is, we mean the topology induced as a subspace of \mathbb{R} . (Sometimes we shall refer to the induced topology on these sets as the “**usual topology**”.)

Exercises 4.1

1. Let $X = \{a, b, c, d, e\}$ and $\mathcal{T} = \{X, \emptyset, \{a\}, \{a, b\}, \{a, c, d\}, \{a, b, c, d\}, \{a, b, e\}\}$. List the members of the induced topologies τ_Y on $Y = \{a, c, e\}$ and τ_Z on $Z = \{b, c, d, e\}$.

2. Describe the topology induced on the set \mathbb{N} of positive integers by the euclidean topology on \mathbb{R} .
3. Write down a basis for the usual topology on each of the following:
 - (i) $[a, b)$, where $a < b$;
 - (ii) $(a, b]$, where $a < b$;
 - (iii) $(-\infty, a]$;
 - (iv) $(-\infty, a)$;
 - (v) (a, ∞) ;
 - (vi) $[a, \infty)$.

[Hint: see Examples 4.1.4 and 4.1.5.]

4. Let $A \subseteq B \subseteq X$ and X have the topology \mathcal{T} . Let \mathcal{T}_B be the subspace topology on B . Further let \mathcal{T}_1 be the topology induced on A by \mathcal{T} , and \mathcal{T}_2 be the topology induced on A by \mathcal{T}_B . Prove that $\mathcal{T}_1 = \mathcal{T}_2$. (So a subspace of a subspace is a subspace.)
5. Let (Y, \mathcal{T}_Y) be a subspace of a space (X, \mathcal{T}) . Show that a subset Z of Y is closed in (Y, \mathcal{T}_Y) if and only if $Z = A \cap Y$, where A is a closed subset of (X, \mathcal{T}) .
6. Show that every subspace of a discrete space is discrete.
7. Show that every subspace of an indiscrete space is indiscrete.
8. Show that the subspace $[0, 1] \cup [3, 4]$ of \mathbb{R} has at least 4 clopen subsets. Exactly how many clopen subsets does it have?
9. Is it true that every subspace of a connected space is connected?
10. Let (Y, \mathcal{T}_Y) be a subspace of (X, \mathcal{T}) . Show that $\mathcal{T}_Y \subseteq \mathcal{T}$ if and only if $Y \in \mathcal{T}$.

[Hint: Remember $Y \in \mathcal{T}_Y$.]

11. Let A and B be connected subspaces of a topological space (X, \mathcal{T}) . If $A \cap B \neq \emptyset$, prove that the subspace $A \cup B$ is connected.

12. Let (Y, \mathcal{T}_1) be a subspace of a T_1 -space (X, \mathcal{T}) . Show that (Y, \mathcal{T}_1) is also a T_1 -space.
13. A topological space (X, \mathcal{T}) is said to be **Hausdorff** (or a **T_2 -space**) if given any pair of distinct points a, b in X there exist open sets U and V such that $a \in U$, $b \in V$, and $U \cap V = \emptyset$.
- (i) Show that \mathbb{R} is Hausdorff.
 - (ii) Prove that every discrete space is Hausdorff.
 - (iii) Show that any T_2 -space is also a T_1 -space.
 - (iv) Show that \mathbb{Z} with the finite-closed topology is a T_1 -space but is not a T_2 -space.
 - (v) Prove that any subspace of a T_2 -space is a T_2 -space.
14. Let (Y, \mathcal{T}_1) be a subspace of a topological space (X, \mathcal{T}) . If (X, \mathcal{T}) satisfies the second axiom of countability, show that (Y, \mathcal{T}_1) also satisfies the second axiom of countability.
15. Let a and b be in \mathbb{R} with $a < b$. Prove that $[a, b]$ is connected.
- [Hint: In the statement and proof of Proposition 3.3.3 replace \mathbb{R} everywhere by $[a, b]$.]
16. Let \mathbb{Q} be the set of all rational numbers with the usual topology and let \mathbb{P} be the set of all irrational numbers with the usual topology.
- (i) Prove that neither \mathbb{Q} nor \mathbb{P} is a discrete space.
 - (ii) Is \mathbb{Q} or \mathbb{P} a connected space?
 - (iii) Is \mathbb{Q} or \mathbb{P} a Hausdorff space?
 - (iv) Does \mathbb{Q} or \mathbb{P} have the finite-closed topology?
17. A topological space (X, \mathcal{T}) is said to be a **regular space** if for any closed subset A of X and any point $x \in X \setminus A$, there exist open sets U and V such that $x \in U$, $A \subseteq V$, and $U \cap V = \emptyset$. If (X, \mathcal{T}) is regular and a T_1 -space, then it is said to be a **T_3 -space**. Prove the following statements.
- (i) Every subspace of a regular space is a regular space.
 - (ii) The spaces \mathbb{R} , \mathbb{Z} , \mathbb{Q} , \mathbb{P} , and \mathbb{R}^2 are regular spaces.
 - (iii) If (X, \mathcal{T}) is a regular T_1 -space, then it is a T_2 -space.

(iv) The Sorgenfrey line is a regular space.

(v)* Let X be the set, \mathbb{R} , of all real numbers and $S = \{\frac{1}{n} : n \in \mathbb{N}\}$. Define a set $C \subseteq \mathbb{R}$ to be closed if $C = A \cup T$, where A is closed in the euclidean topology on \mathbb{R} and T is any subset of S . The complements of these closed sets form a topology \mathcal{T} on \mathbb{R} which is Hausdorff but not regular.

4.2 Homeomorphisms

We now turn to the notion of equivalent topological spaces. We begin by considering an example:

$$X = \{a, b, c, d, e\}, \quad Y = \{g, h, i, j, k\},$$

$$\mathcal{T} = \{X, \emptyset, \{a\}, \{c, d\}, \{a, c, d\}, \{b, c, d, e\}\}$$

and

$$\mathcal{T}_1 = \{Y, \emptyset, \{g\}, \{i, j\}, \{g, i, j\}, \{h, i, j, k\}\}.$$

It is clear that in an intuitive sense (X, \mathcal{T}) is “equivalent” to (Y, \mathcal{T}_1) . The function $f: X \rightarrow Y$ defined by $f(a) = g$, $f(b) = h$, $f(c) = i$, $f(d) = j$, and $f(e) = k$, provides the equivalence. We now formalize this.

4.2.1 Definition. Let (X, \mathcal{T}) and (Y, \mathcal{T}_1) be topological spaces. Then they are said to be **homeomorphic** if there exists a function $f: X \rightarrow Y$ which has the following properties:

- (i) f is one-to-one (that is $f(x_1) = f(x_2)$ implies $x_1 = x_2$),
- (ii) f is onto (that is, for any $y \in Y$ there exists an $x \in X$ such that $f(x) = y$),
- (iii) for each $U \in \mathcal{T}_1$, $f^{-1}(U) \in \mathcal{T}$, and
- (iv) for each $V \in \mathcal{T}$, $f(V) \in \mathcal{T}_1$.

Further, the map f is said to be a **homeomorphism** between (X, \mathcal{T}) and (Y, \mathcal{T}_1) . We write $(X, \mathcal{T}) \cong (Y, \mathcal{T}_1)$.

□

We shall show that “ \cong ” is an equivalence relation and use this to show that all open intervals (a, b) are homeomorphic to each other. Example 4.2.2 is the first step, as it shows that “ \cong ” is a transitive relation.

4.2.2 Example. Let $(X, \mathcal{T}), (Y, \mathcal{T}_1)$ and (Z, \mathcal{T}_2) be topological spaces. If $(X, \mathcal{T}) \cong (Y, \mathcal{T}_1)$ and $(Y, \mathcal{T}_1) \cong (Z, \mathcal{T}_2)$, prove that $(X, \mathcal{T}) \cong (Z, \mathcal{T}_2)$.

Proof.

We are given that $(X, \mathcal{T}) \cong (Y, \mathcal{T}_1)$; that is, there exists a homeomorphism $f : (X, \mathcal{T}) \rightarrow (Y, \mathcal{T}_1)$. We are also given that $(Y, \mathcal{T}_1) \cong (Z, \mathcal{T}_2)$; that is, there exists a homeomorphism $g : (Y, \mathcal{T}_1) \rightarrow (Z, \mathcal{T}_2)$.

We are required to prove that $(X, \mathcal{T}) \cong (Z, \mathcal{T}_2)$; that is, we need to find a homeomorphism $h : (X, \mathcal{T}) \rightarrow (Z, \mathcal{T}_2)$. We will prove that the composite map $g \circ f : X \rightarrow Z$ is the required homeomorphism.

As $(X, \mathcal{T}) \cong (Y, \mathcal{T}_1)$ and $(Y, \mathcal{T}_1) \cong (Z, \mathcal{T}_2)$, there exist homeomorphisms $f : (X, \mathcal{T}) \rightarrow (Y, \mathcal{T}_1)$ and $g : (Y, \mathcal{T}_1) \rightarrow (Z, \mathcal{T}_2)$. Consider the composite map $g \circ f : X \rightarrow Z$. [Thus $g \circ f(x) = g(f(x))$, for all $x \in X$.] It is a routine task to verify that $g \circ f$ is one-to-one and onto. Now let $U \in \mathcal{T}_2$. Then, as g is a homeomorphism $g^{-1}(U) \in \mathcal{T}_1$. Using the fact that f is a homeomorphism we obtain that $f^{-1}(g^{-1}(U)) \in \mathcal{T}$. But $f^{-1}(g^{-1}(U)) = (g \circ f)^{-1}(U)$. So $g \circ f$ has property (iii) of Definition 4.2.1. Next let $V \in \mathcal{T}$. Then $f(V) \in \mathcal{T}_1$ and so $g(f(V)) \in \mathcal{T}_2$; that is $g \circ f(V) \in \mathcal{T}_2$ and we see that $g \circ f$ has property (iv) of Definition 4.2.1. Hence $g \circ f$ is a homeomorphism. \square

4.2.3 Remark. Example 4.2.2 shows that “ \cong ” is a transitive relation. Indeed it is easily verified that it is an equivalence relation; that is,

(i) $(X, \mathcal{T}) \cong (X, \mathcal{T})$ [Reflexive]

(ii) $(X, \mathcal{T}) \cong (Y, \mathcal{T}_1)$ implies $(Y, \mathcal{T}_1) \cong (X, \mathcal{T})$ [Symmetric]

[Observe that if $f : (X, \mathcal{T}) \rightarrow (Y, \mathcal{T}_1)$ is a homeomorphism, then its inverse $f^{-1} : (Y, \mathcal{T}_1) \rightarrow (X, \mathcal{T})$ is also a homeomorphism.]

(iii) $(X, \mathcal{T}) \cong (Y, \mathcal{T}_1)$ and $(Y, \mathcal{T}_1) \cong (Z, \mathcal{T}_2)$ implies $(X, \mathcal{T}) \cong (Z, \mathcal{T}_2)$. [Transitive].

□

The next three examples show that all open intervals in \mathbb{R} are homeomorphic. Length is certainly not a topological property. In particular, an open interval of finite length, such as $(0, 1)$, is homeomorphic to one of infinite length, such as $(-\infty, 1)$. Indeed all open intervals are homeomorphic to \mathbb{R} .

4.2.4 Example. Prove that any two non-empty open intervals (a, b) and (c, d) are homeomorphic.

Outline Proof.

By Remark 4.2.3 it suffices to show that (a, b) is homeomorphic to $(0, 1)$ and (c, d) is homeomorphic to $(0, 1)$. But as a and b are arbitrary (except that $a < b$), if (a, b) is homeomorphic to $(0, 1)$ then (c, d) is also homeomorphic to $(0, 1)$. To prove that (a, b) is homeomorphic to $(0, 1)$ it suffices to find a homeomorphism $f : (0, 1) \rightarrow (a, b)$.

Let $a, b, \in \mathbb{R}$ with $a < b$ and consider the function $f : (0, 1) \rightarrow (a, b)$ given by

$$f(x) = a(1 - x) + bx.$$

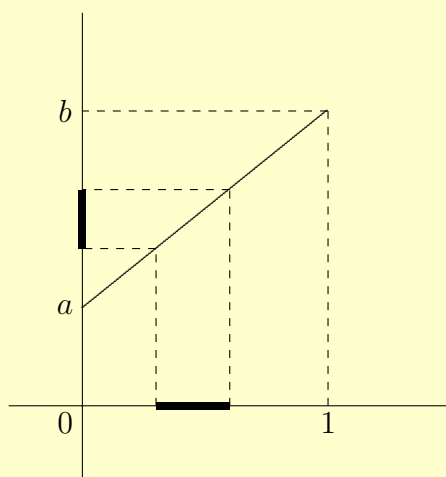

Clearly $f : (0, 1) \rightarrow (a, b)$ is one-to-one and onto. It is also clear from the diagram that the image under f of any open interval in $(0, 1)$ is an open interval in (a, b) ; that is,

$$f(\text{open interval in } (0, 1)) = \text{an open interval in } (a, b).$$

But every open set in $(0, 1)$ is a union of open intervals in $(0, 1)$ and so

$$\begin{aligned} f(\text{open set in } (0, 1)) &= f(\text{union of open intervals in } (0, 1)) \\ &= \text{union of open intervals in } (a, b) \\ &= \text{open set in } (a, b). \end{aligned}$$

So condition (iv) of Definition 4.2.1 is satisfied. Similarly, we see that f^{-1} (open set in (a, b)) is an open set in $(0, 1)$. So condition (iii) of Definition 4.2.1 is also satisfied.

[Exercise: write out the above proof carefully.]

Hence f is a homeomorphism and $(0, 1) \cong (a, b)$, for all $a, b \in \mathbb{R}$ with $a < b$.

From the above it immediately follows that $(a, b) \cong (c, d)$, as required. □

4.2.5 Example. Prove that the space \mathbb{R} is homeomorphic to the open interval $(-1, 1)$ with the usual topology.

Outline Proof. Define $f : (-1, 1) \rightarrow \mathbb{R}$ by

$$f(x) = \frac{x}{1 - |x|}.$$

It is readily verified that f is one-to-one and onto, and a diagrammatic argument like that in Example 4.2.2 indicates that f is a homeomorphism.

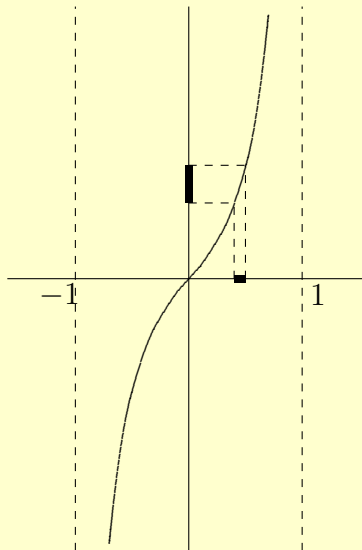

[Exercise: write out a proof that f is a homeomorphism.]

□

4.2.6 Example. Prove that every open interval (a, b) , with $a < b$, is homeomorphic to \mathbb{R} .

Proof. This follows immediately from Examples 4.2.5 and 4.2.4 and Remark 4.2.3.

□

4.2.7 Remark. It can be proved in a similar fashion that any two intervals $[a, b]$ and $[c, d]$, with $a < b$ and $c < d$, are homeomorphic.

□

Exercises 4.2

1. (i) If a, b, c , and d are real numbers with $a < b$ and $c < d$, prove that $[a, b] \cong [c, d]$.

(ii) If a and b are any real numbers, prove that

$$(-\infty, a] \cong (-\infty, b] \cong [a, \infty) \cong [b, \infty).$$

(iii) If c, d, e , and f are any real numbers with $c < d$ and $e < f$, prove that

$$[c, d] \cong [e, f] \cong (c, d] \cong (e, f].$$

(iv) Deduce that for any real numbers a and b with $a < b$,

$$[0, 1) \cong (-\infty, a] \cong [a, \infty) \cong [a, b) \cong (a, b].$$

2. Prove that $\mathbb{Z} \cong \mathbb{N}$

3. Let m and c be non-zero real numbers and X the subspace of \mathbb{R}^2 given by $X = \{\langle x, y \rangle : y = mx + c\}$. Prove that X is homeomorphic to \mathbb{R} .

4. (i) Let X_1 and X_2 be the closed rectangular regions in \mathbb{R}^2 given by

$$X_1 = \{\langle x, y \rangle : |x| \leq a_1 \text{ and } |y| \leq b_1\}$$

and

$$X_2 = \{\langle x, y \rangle : |x| \leq a_2 \text{ and } |y| \leq b_2\}$$

where a_1, b_1, a_2 , and b_2 are positive real numbers. If X_1 and X_2 are given the induced topologies from \mathbb{R}^2 , show that $X_1 \cong X_2$.

(ii) Let D_1 and D_2 be the closed discs in \mathbb{R}^2 given by

$$D_1 = \{\langle x, y \rangle : x^2 + y^2 \leq c_1\}$$

and

$$D_2 = \{\langle x, y \rangle : x^2 + y^2 \leq c_2\}$$

where c_1 and c_2 are positive real numbers. Prove that the topological space $D_1 \cong D_2$, where D_1 and D_2 have their subspace topologies.

(iii) Prove that $X_1 \cong D_1$.

5. Let X_1 and X_2 be subspaces of \mathbb{R} given by $X_1 = (0, 1) \cup (3, 4)$ and $X_2 = (0, 1) \cup (1, 2)$. Is $X_1 \cong X_2$? (Justify your answer.)
6. (**Group of Homeomorphisms**) Let (X, \mathcal{T}) be any topological space and G the set of all homeomorphisms of X into itself.
- (i) Show that G is a group under the operation of composition of functions.
 - (ii) If $X = [0, 1]$, show that G is infinite.
 - (iii) If $X = [0, 1]$, is G an abelian group?
7. Let (X, \mathcal{T}) and (Y, \mathcal{T}_1) be homeomorphic topological spaces. Prove that
- (i) If (X, \mathcal{T}) is a T_0 -space, then (Y, \mathcal{T}_1) is a T_0 -space.
 - (ii) If (X, \mathcal{T}) is a T_1 -space, then (Y, \mathcal{T}_1) is a T_1 -space.
 - (iii) If (X, \mathcal{T}) is a Hausdorff space, then (Y, \mathcal{T}_1) is a Hausdorff space.
 - (iv) If (X, \mathcal{T}) satisfies the second axiom of countability, then (Y, \mathcal{T}_1) satisfies the second axiom of countability.
 - (v) If (X, \mathcal{T}) is a separable space, then (Y, \mathcal{T}_1) is a separable space.
- 8.* Let (X, \mathcal{T}) be a discrete topological space. Prove that (X, \mathcal{T}) is homeomorphic to a subspace of \mathbb{R} if and only if X is countable.

4.3 Non-Homeomorphic Spaces

To prove two topological spaces are homeomorphic we have to find a homeomorphism between them.

But, to prove that two topological spaces are not homeomorphic is often much harder as we have to show that no homeomorphism exists. The following example gives us a clue as to how we might go about showing this.

4.3.1 Example. Prove that $[0, 2]$ is not homeomorphic to the subspace $[0, 1] \cup [2, 3]$ of \mathbb{R} .

Proof. Let $(X, \mathcal{T}) = [0, 2]$ and $(Y, \mathcal{T}_1) = [0, 1] \cup [2, 3]$. Then

$$[0, 1] = [0, 1] \cap Y \Rightarrow [0, 1] \text{ is closed in } (Y, \mathcal{T}_1)$$

and

$$[0, 1] = (-1, 1\frac{1}{2}) \cap Y \Rightarrow [0, 1] \text{ is open in } (Y, \mathcal{T}_1).$$

Thus Y is not connected, as it has $[0, 1]$ as a proper non-empty clopen subset.

Suppose that $(X, \mathcal{T}) \cong (Y, \mathcal{T}_1)$. Then there exists a homeomorphism $f: (X, \mathcal{T}) \rightarrow (Y, \mathcal{T}_1)$. So $f^{-1}([0, 1])$ is a clopen subset of X , and hence X is not connected. This is false as $[0, 2] = X$ is connected. (See Exercises 4.1 #15.) So we have a contradiction and thus $(X, \mathcal{T}) \not\cong (Y, \mathcal{T}_1)$. \square

What do we learn from this?

4.3.2 Proposition. Any topological space homeomorphic to a connected space is connected. \square

Proposition 4.3.2 gives us one way to try to show two topological spaces are not homeomorphic ... by finding a property “preserved by homeomorphisms” which one space has and the other does not.

Amongst the exercises we have met many properties “preserved by homeomorphisms”:

- (i) T_0 -space;
- (ii) T_1 -space;
- (iii) T_2 -space or Hausdorff space;
- (iv) regular space;
- (v) T_3 -space;
- (vi) satisfying the second axiom of countability;
- (vii) separable space. [See Exercises 4.2 #7.]

There are also others:

- (viii) discrete space;
- (ix) indiscrete space;
- (x) finite-closed topology;
- (xi) countable-closed topology.

So together with connectedness we know twelve properties preserved by homeomorphisms. Also two spaces (X, \mathcal{T}) and (Y, \mathcal{T}_1) cannot be homeomorphic if X and Y have different cardinalities or if \mathcal{T} and \mathcal{T}_1 have different cardinalities, e.g. X is countable and Y is uncountable.

Nevertheless when faced with a specific problem we may not have the one we need. For example, show that $(0, 1)$ is not homeomorphic to $[0, 1]$ or show that \mathbb{R} is not homeomorphic to \mathbb{R}^2 . We shall see how to show that these spaces are not homeomorphic shortly.

Before moving on to this let us settle the following question: which subspaces of \mathbb{R} are connected?

4.3.3 Definition. A subset S of \mathbb{R} is said to be an **interval** if it has the following property: if $x \in S$, $z \in S$, and $y \in \mathbb{R}$ are such that $x < y < z$, then $y \in S$.

4.3.4 Remarks. Note that each singleton set $\{x\}$ is an interval.

- (ii) Every interval has one of the following forms: $\{a\}$, $[a, b]$, (a, b) , $[a, b)$, $(a, b]$, $(-\infty, a)$, $(-\infty, a]$, (a, ∞) , $[a, \infty)$, $(-\infty, \infty)$.
- (iii) It follows from Example 4.2.6, Remark 4.2.7, and Exercises 4.2 #1, that every interval is homeomorphic to $(0, 1)$, $[0, 1]$, $[0, 1)$, or $\{0\}$. In Exercises 4.3 #1 we are able to make an even stronger statement.

4.3.5 Proposition. A subspace S of \mathbb{R} is connected if and only if it is an interval.

Proof. That all intervals are connected can be proved in a similar fashion to Proposition 3.3.3 by replacing \mathbb{R} everywhere in the proof by the interval we are trying to prove connected.

Conversely, let S be connected. Suppose $x \in S$, $z \in S$, $x < y < z$, and $y \notin S$. Then $(-\infty, y) \cap S = (-\infty, y] \cap S$ is an open and closed subset of S . So S has a clopen subset, namely $(-\infty, y) \cap S$. To show that S is not connected we have to verify only that this clopen set is proper and non-empty. It is non-empty as it contains x . It is proper as $z \in S$ but $z \notin (-\infty, y) \cap S$. So S is not connected. This is a contradiction. Therefore S is an interval. \square

We now see a reason for the name “connected”. Subspaces of \mathbb{R} such as $[a, b]$, (a, b) , etc. are connected, while subspaces like

$$X = [0, 1] \cup [2, 3] \cup [5, 6]$$

which is a union of “disconnected” pieces, are not connected.

Now let us turn to the problem of showing that $(0, 1) \not\cong [0, 1]$. Firstly, we present a seemingly trivial observation.

4.3.6 Remark. Let $f : (X, \mathcal{T}) \rightarrow (Y, \mathcal{T}_1)$ be a homeomorphism. Let $a \in X$, so that $X \setminus \{a\}$ is a subspace of X and has induced topology \mathcal{T}_2 . Also $Y \setminus \{f(a)\}$ is a subspace of Y and has induced topology \mathcal{T}_3 . Then $(X \setminus \{a\}, \mathcal{T}_2)$ is homeomorphic to $(Y \setminus \{f(a)\}, \mathcal{T}_3)$.

Outline Proof. Define $g : X \setminus \{a\} \rightarrow Y \setminus \{f(a)\}$ by $g(x) = f(x)$, for all $x \in X \setminus \{a\}$. Then it is easily verified that g is a homeomorphism. (Write down a proof of this.) \square

As an immediate consequence of this we have:

4.3.7 Corollary. If a, b, c , and d are real numbers with $a < b$ and $c < d$, then

- (i) $(a, b) \not\cong [c, d]$,
- (ii) $(a, b) \not\cong [c, d]$, and
- (iii) $[a, b] \not\cong [c, d]$.

Proof. Let $(X, \mathcal{T}) = [c, d]$ and $(Y, \mathcal{T}_1) = (a, b)$. **Suppose** that $(X, \mathcal{T}) \cong (Y, \mathcal{T}_1)$. Then $X \setminus \{c\} \cong Y \setminus \{y\}$, for some $y \in Y$. But, $X \setminus \{c\} = (c, d)$, an interval, and so is connected, while no matter which point we remove from (a, b) the resultant space is disconnected. Hence

$$X \setminus \{c\} \not\cong Y \setminus \{y\}, \text{ for each } y \in Y.$$

This is a contradiction. So $[c, d] \not\cong (a, b)$.

(ii) $[c, d] \setminus \{c\}$ is connected, while $(a, b) \setminus \{y\}$ is disconnected for all $y \in (a, b)$. Thus $(a, b) \not\cong [c, d]$.

(iii) **Suppose** that $[a, b] \cong [c, d]$. Then $[c, d] \setminus \{c\} \cong [a, b] \setminus \{y\}$ for some $y \in [a, b]$. Therefore $([c, d] \setminus \{c\}) \setminus \{d\} \cong ([a, b] \setminus \{y\}) \setminus \{z\}$, for some $z \in [a, b] \setminus \{y\}$; that is, $(c, d) \cong [a, b] \setminus \{y, z\}$, for some distinct y and z in $[a, b]$. But (c, d) is connected, while $[a, b] \setminus \{y, z\}$, for any two distinct points y and z in $[a, b]$, is disconnected. So we have a contradiction. Therefore $[a, b] \not\cong [c, d]$. \square

Exercises 4.3

1. Deduce from the above that every interval is homeomorphic to one and only one of the following spaces:

$$\{0\}; \quad (0, 1); \quad [0, 1]; \quad [0, 1).$$

2. Deduce from Proposition 4.3.5 that every countable subspace of \mathbb{R} with more than one point is disconnected. (In particular, \mathbb{Z} and \mathbb{Q} are disconnected.)
3. Let X be the unit circle in \mathbb{R}^2 ; that is, $X = \{\langle x, y \rangle : x^2 + y^2 = 1\}$ and has the subspace topology.

(i) Show that $X \setminus \{\langle 1, 0 \rangle\}$ is homeomorphic to the open interval $(0, 1)$.

(ii) Deduce that $X \not\cong (0, 1)$ and $X \not\cong [0, 1]$.

– (iii)] Observing that for every point $a \in X$, the subspace $X \setminus \{a\}$ is connected, show that $X \not\cong [0, 1)$.

(iv) Deduce that X is not homeomorphic to any interval.

4. Let Y be the subspace of \mathbb{R}^2 given by

$$Y = \{\langle x, y \rangle : x^2 + y^2 = 1\} \cup \{\langle x, y \rangle : (x - 2)^2 + y^2 = 1\}$$

(i) Is Y homeomorphic to the space X in Exercise 3 above?

(ii) Is Y homeomorphic to an interval?

5. Let Z be the subspace of \mathbb{R}^2 given by

$$Z = \{\langle x, y \rangle : x^2 + y^2 = 1\} \cup \{\langle x, y \rangle : (x - 3/2)^2 + y^2 = 1\}.$$

Show that

(i) Z is not homeomorphic to any interval, and

(ii) Z is not homeomorphic to X or Y , the spaces described in Exercises 3 and 4 above.

6. Prove that the Sorgenfrey line is not homeomorphic to \mathbb{R} , \mathbb{R}^2 , or any subspace of either of these spaces.

7. (i) Prove that the topological space in Exercises 1.1 #5 (i) is not homeomorphic to the space in Exercises 1.1 #9 (ii).
- (ii)* In Exercises 1.1 #5, is $(X, \mathcal{T}_1) \cong (X, \mathcal{T}_2)$?
- (iii)* In Exercises 1.1 # 9, is $(X, \mathcal{T}_2) \cong (X, \mathcal{T}_9)$?
8. Let (X, \mathcal{T}) be a topological space, where X is an infinite set. Prove each of the following statements (originally proved by John Ginsburg and Bill Sands).
- (i)* (X, \mathcal{T}) has a subspace homeomorphic to $(\mathbb{N}, \mathcal{T}_1)$, where either \mathcal{T}_1 is the indiscrete topology or $(\mathbb{N}, \mathcal{T}_1)$ is a T_0 -space.
- (ii)** Let (X, \mathcal{T}) be a T_1 -space. Then (X, \mathcal{T}) has a subspace homeomorphic to $(\mathbb{N}, \mathcal{T}_2)$, where \mathcal{T}_2 is either the finite-closed topology or the discrete topology.
- (iii) Deduce from (ii), that any infinite Hausdorff space contains an infinite discrete subspace and hence a subspace homeomorphic to \mathbb{N} with the discrete topology.
- (iv)** Let (X, \mathcal{T}) be a T_0 -space which is not a T_1 -space. Then the space (X, \mathcal{T}) has a subspace homeomorphic to $(\mathbb{N}, \mathcal{T}_3)$, where \mathcal{T}_3 consists of \mathbb{N} , \emptyset , and all of the sets $\{1, 2, \dots, n\}$, $n \in \mathbb{N}$ or \mathcal{T}_3 consists of \mathbb{N} , \emptyset , and all of the sets $\{n, n + 1, \dots\}$, $n \in \mathbb{N}$.
- (v) Deduce from the above that every infinite topological space has a subspace homeomorphic to $(\mathbb{N}, \mathcal{T}_4)$ where \mathcal{T}_4 is the indiscrete topology, the discrete topology, the finite-closed topology, or one of the two topologies described in (iv), known as the **initial segment topology** and the **final segment topology**, respectively. Further, no two of these five topologies on \mathbb{N} are homeomorphic.

9. Let (X, \mathcal{T}) and (Y, \mathcal{T}_1) be topological spaces. A map $f : X \rightarrow Y$ is said to be a **local homeomorphism** if each point $x \in X$ has an open neighbourhood U such that f maps U homeomorphically onto an open subspace V of (Y, \mathcal{T}_1) ; that is, if the topology induced on U by \mathcal{T} is \mathcal{T}_2 and the topology induced on $V = f(U)$ by \mathcal{T}_1 is \mathcal{T}_3 , then f is a homeomorphism of (U, \mathcal{T}_2) onto (V, \mathcal{T}_3) . The topological space (X, \mathcal{T}) is said to be **locally homeomorphic** to (Y, \mathcal{T}_1) if there exists a local homeomorphism of (X, \mathcal{T}) into (Y, \mathcal{T}_1) .
- (i) If (X, \mathcal{T}) and (Y, \mathcal{T}_1) are homeomorphic topological spaces, verify that (X, \mathcal{T}) is locally homeomorphic to (Y, \mathcal{T}_1) .
 - (ii) If (X, \mathcal{T}) is an open subspace of (Y, \mathcal{T}_1) , prove that (X, \mathcal{T}) is locally homeomorphic to (Y, \mathcal{T}_1) .
 - (iii)* Prove that if $f : (X, \mathcal{T}) \rightarrow (Y, \mathcal{T}_1)$ is a local homeomorphism, then f maps every open subset of (X, \mathcal{T}) onto an open subset of (Y, \mathcal{T}_1) .

4.4 Postscript

There are three important ways of creating new topological spaces from old ones: forming subspaces, products, and quotient spaces. We examine all three in due course. Forming subspaces was studied in this section. This allowed us to introduce the important spaces \mathbb{Q} , $[a, b]$, (a, b) , etc.

We defined the central notion of homeomorphism. We noted that “ \cong ” is an equivalence relation. A property is said to be **topological** if it is preserved by homeomorphisms; that is, if $(X, \mathcal{T}) \cong (Y, \mathcal{T}_1)$ and (X, \mathcal{T}) has the property then (Y, \mathcal{T}_1) must also have the property. Connectedness was shown to be a topological property. So any space homeomorphic to a connected space is connected. (A number of other topological properties were also identified.) We formally defined the notion of an interval in \mathbb{R} , and showed that the intervals are precisely the connected subspaces of \mathbb{R} .

Given two topological spaces (X, \mathcal{T}) and (Y, \mathcal{T}_1) it is an interesting task to show whether they are homeomorphic or not. We proved that every interval in \mathbb{R} is homeomorphic to one and only one of $[0, 1]$, $(0, 1)$, $[0, 1)$, and $\{0\}$. In the next section we show that \mathbb{R} is not homeomorphic to \mathbb{R}^2 . A tougher problem is to show that \mathbb{R}^2 is not homeomorphic to \mathbb{R}^3 . This will be done later via the Jordan curve theorem. Still the *crème de la crème* is the fact that $\mathbb{R}^n \cong \mathbb{R}^m$ if and only if $n = m$. This is best approached via algebraic topology, which is only touched upon in this book.

Exercises 4.2 #6 introduced the notion of group of homeomorphisms, which is an interesting and important topic in its own right.

Chapter 5

Continuous Mappings

Introduction

In most branches of pure mathematics we study what in category theory are called “objects” and “arrows”. In linear algebra the objects are vector spaces and the arrows are linear transformations. In group theory the objects are groups and the arrows are homomorphisms, while in set theory the objects are sets and the arrows are functions. In topology the objects are the topological spaces. We now introduce the arrows ... the continuous mappings.

5.1 Continuous Mappings

Of course we are already familiar¹ with the notion of a continuous function from \mathbb{R} into \mathbb{R} .

A function $f : \mathbb{R} \rightarrow \mathbb{R}$ is said to be **continuous** if for each $a \in \mathbb{R}$ and each positive real number ε , there exists a positive real number δ such that $|x - a| < \delta$ implies $|f(x) - f(a)| < \varepsilon$.

It is not at all obvious how to generalize this definition to general topological spaces where we do not have “absolute value” or “subtraction”. So we shall seek another (equivalent) definition of continuity which lends itself more to generalization.

It is easily seen that $f : \mathbb{R} \rightarrow \mathbb{R}$ is continuous if and only if for each $a \in \mathbb{R}$ and each interval $(f(a) - \varepsilon, f(a) + \varepsilon)$, for $\varepsilon > 0$, there exists a $\delta > 0$ such that $f(x) \in (f(a) - \varepsilon, f(a) + \varepsilon)$ for all $x \in (a - \delta, a + \delta)$.

This definition is an improvement since it does not involve the concept “absolute value” but it still involves “subtraction”. The next lemma shows how to avoid subtraction.

¹The early part of this section assumes that you have some knowledge of real analysis and, in particular, the ε - δ definition of continuity. If this is not the case, then proceed directly to Definition 5.1.3.

5.1.1 Lemma. Let f be a function mapping \mathbb{R} into itself. Then f is continuous if and only if for each $a \in \mathbb{R}$ and each open set U containing $f(a)$, there exists an open set V containing a such that $f(V) \subseteq U$.

Proof. Assume that f is continuous. Let $a \in \mathbb{R}$ and let U be any open set containing $f(a)$. Then there exist real numbers c and d such that $f(a) \in (c, d) \subseteq U$. Put ε equal to the smaller of the two numbers $d - f(a)$ and $f(a) - c$, so that

$$(f(a) - \varepsilon, f(a) + \varepsilon) \subseteq U.$$

As the mapping f is continuous there exists a $\delta > 0$ such that $f(x) \in (f(a) - \varepsilon, f(a) + \varepsilon)$ for all $x \in (a - \delta, a + \delta)$. Let V be the open set $(a - \delta, a + \delta)$. Then $a \in V$ and $f(V) \subseteq U$, as required.

Conversely assume that for each $a \in \mathbb{R}$ and each open set U containing $f(a)$ there exists an open set V containing a such that $f(V) \subseteq U$. We have to show that f is continuous. Let $a \in \mathbb{R}$ and ε be any positive real number. Put $U = (f(a) - \varepsilon, f(a) + \varepsilon)$. So U is an open set containing $f(a)$. Therefore there exists an open set V containing a such that $f(V) \subseteq U$. As V is an open set containing a , there exist real numbers c and d such that $a \in (c, d) \subseteq V$. Put δ equal to the smaller of the two numbers $d - a$ and $a - c$, so that $(a - \delta, a + \delta) \subseteq V$. Then for all $x \in (a - \delta, a + \delta)$, $f(x) \in f(V) \subseteq U$, as required. So f is continuous. \square

We could use the property described in Lemma 5.1.1 to define continuity, however the following lemma allows us to make a more elegant definition.

5.1.2 Lemma. Let f be a mapping of a topological space (X, \mathcal{T}) into a topological space (Y, \mathcal{T}') . Then the following two conditions are equivalent:

- (i) for each $U \in \mathcal{T}'$, $f^{-1}(U) \in \mathcal{T}$,
- (ii) for each $a \in X$ and each $U \in \mathcal{T}'$ with $f(a) \in U$, there exists a $V \in \mathcal{T}$ such that $a \in V$ and $f(V) \subseteq U$.

Proof. Assume that condition (i) is satisfied. Let $a \in X$ and $U \in \mathcal{T}'$ with $f(a) \in U$. Then $f^{-1}(U) \in \mathcal{T}$. Put $V = f^{-1}(U)$, and we have that $a \in V$, $V \in \mathcal{T}$, and $f(V) \subseteq U$. So condition (ii) is satisfied.

Conversely, assume that condition (ii) is satisfied. Let $U \in \mathcal{T}'$. If $f^{-1}(U) = \emptyset$ then clearly $f^{-1}(U) \in \mathcal{T}$. If $f^{-1}(U) \neq \emptyset$, let $a \in f^{-1}(U)$. Then $f(a) \in U$. Therefore there exists a $V \in \mathcal{T}$ such that $a \in V$ and $f(V) \subseteq U$. So for each $a \in f^{-1}(U)$ there exists a $V \in \mathcal{T}$ such that $a \in V \subseteq f^{-1}(U)$. By Corollary 3.2.9 this implies that $f^{-1}(U) \in \mathcal{T}$. So condition (i) is satisfied. \square

So putting together Lemmas 5.1.1 and 5.1.2 we see that $f : \mathbb{R} \rightarrow \mathbb{R}$ is continuous if and only if for each open subset U of \mathbb{R} , $f^{-1}(U)$ is an open set.

This leads us to define the notion of a continuous function between two topological spaces as follows:

5.1.3 Definition. Let (X, \mathcal{T}) and (Y, \mathcal{T}_1) be topological spaces and f a function from X into Y . Then $f : (X, \mathcal{T}) \rightarrow (Y, \mathcal{T}_1)$ is said to be a **continuous mapping** if for each $U \in \mathcal{T}_1$, $f^{-1}(U) \in \mathcal{T}$.

From the above remarks we see that this definition of continuity coincides with the usual definition when $(X, \mathcal{T}) = (Y, \mathcal{T}_1) = \mathbb{R}$.

Let us go through a few easy examples to see how nice this definition of continuity is to apply in practice.

5.1.4 Example. Consider $f : \mathbb{R} \rightarrow \mathbb{R}$ given by $f(x) = x$, for all $x \in \mathbb{R}$; that is, f is the identity function. Then for any open set U in \mathbb{R} , $f^{-1}(U) = U$ and so is open. Hence f is continuous. \square

5.1.5 Example. Let $f : \mathbb{R} \rightarrow \mathbb{R}$ be given by $f(x) = c$, for c a constant, and all $x \in \mathbb{R}$. Then let U be any open set in \mathbb{R} . Clearly $f^{-1}(U) = \mathbb{R}$ if $c \in U$ and \emptyset if $c \notin U$. In both cases, $f^{-1}(U)$ is open. So f is continuous. \square

5.1.6 Example. Consider $f : \mathbb{R} \rightarrow \mathbb{R}$ defined by

$$f(x) = \begin{cases} x - 1, & \text{if } x \leq 3 \\ \frac{1}{2}(x + 5), & \text{if } x > 3. \end{cases}$$

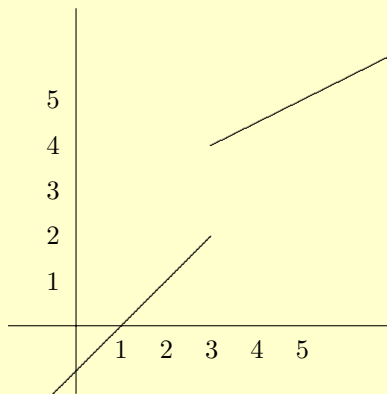

Recall that a mapping is continuous if and only if the inverse image of every open set is an open set.

Therefore, to show f is not continuous we have to find only one set U such that $f^{-1}(U)$ is not open.

Then $f^{-1}((1, 3)) = (2, 3]$, which is not an open set. Therefore f is not continuous. \square

Note that Lemma 5.1.2 can now be restated in the following way.²

5.1.7 Proposition. Let f be a mapping of a topological space (X, \mathcal{T}) into a space (Y, \mathcal{T}') . Then f is continuous if and only if for each $x \in X$ and each $U \in \mathcal{T}'$ with $f(x) \in U$, there exists a $V \in \mathcal{T}$ such that $x \in V$ and $f(V) \subseteq U$. \square

5.1.8 Proposition. Let $(X, \mathcal{T}), (Y, \mathcal{T}_1)$ and (Z, \mathcal{T}_2) be topological spaces. If $f : (X, \mathcal{T}) \rightarrow (Y, \mathcal{T}_1)$ and $g : (Y, \mathcal{T}_1) \rightarrow (Z, \mathcal{T}_2)$ are continuous mappings, then the composite function $g \circ f : (X, \mathcal{T}) \rightarrow (Z, \mathcal{T}_2)$ is continuous.

Proof.

To prove that the composite function $g \circ f : (X, \mathcal{T}) \rightarrow (Z, \mathcal{T}_2)$ is continuous, we have to show that if $U \in \mathcal{T}_2$, then $(g \circ f)^{-1}(U) \in \mathcal{T}$.

But $(g \circ f)^{-1}(U) = f^{-1}(g^{-1}(U))$.

Let U be open in (Z, \mathcal{T}_2) . Since g is continuous, $g^{-1}(U)$ is open in \mathcal{T}_1 . Then $f^{-1}(g^{-1}(U))$ is open in \mathcal{T} as f is continuous. But $f^{-1}(g^{-1}(U)) = (g \circ f)^{-1}(U)$. Thus $g \circ f$ is continuous. \square

The next result shows that continuity can be described in terms of closed sets instead of open sets if we wish.

5.1.9 Proposition. Let (X, \mathcal{T}) and (Y, \mathcal{T}_1) be topological spaces. Then $f : (X, \mathcal{T}) \rightarrow (Y, \mathcal{T}_1)$ is continuous if and only if for every closed subset S of Y , $f^{-1}(S)$ is a closed subset of X .

Proof. This result follows immediately once you recognize that

$$f^{-1}(\text{complement of } S) = \text{complement of } f^{-1}(S).$$

\square

²If you have not read Lemma 5.1.2 and its proof you should do so now.

5.1.10 Remark. There is a relationship between continuous maps and homeomorphisms: if $f : (X, \mathcal{T}) \rightarrow (Y, \mathcal{T}_1)$ is a homeomorphism then it is a continuous map. Of course not every continuous map is a homeomorphism.

However the following proposition, whose proof follows from the definitions of “continuous” and “homeomorphism” tells the full story.

5.1.11 Proposition. Let (X, \mathcal{T}) and (Y, \mathcal{T}') be topological spaces and f a function from X into Y . Then f is a homeomorphism if and only if

- (i) f is continuous,
- (ii) f is one-to-one and onto; that is, the inverse function $f^{-1} : Y \rightarrow X$ exists, and
- (iii) f^{-1} is continuous. □

A useful result is the following proposition which tells us that the restriction of a continuous map is a continuous map. Its routine proof is left to the reader – see also Exercise Set 5.1 #8.

5.1.12 Proposition. Let (X, \mathcal{T}) and (Y, \mathcal{T}_1) be topological spaces, $f : (X, \mathcal{T}) \rightarrow (Y, \mathcal{T}_1)$ a continuous mapping, A a subset of X , and \mathcal{T}_2 the induced topology on A . Further let $g : (A, \mathcal{T}_2) \rightarrow (Y, \mathcal{T}_1)$ be the restriction of f to A ; that is, $g(x) = f(x)$, for all $x \in A$. Then g is continuous.

Exercises 5.1

1. (i) Let $f : (X, \mathcal{T}) \rightarrow (Y, \mathcal{T}_1)$ be a constant function. Show that f is continuous.
 (ii) Let $f : (X, \mathcal{T}) \rightarrow (X, \mathcal{T})$ be the identity function. Show that f is continuous.

2. Let $f : \mathbb{R} \rightarrow \mathbb{R}$ be given by

$$f(x) = \begin{cases} -1, & x \leq 0 \\ 1, & x > 0. \end{cases}$$

- (i) Prove that f is not continuous using the method of Example 5.1.6.
 (ii) Find $f^{-1}\{1\}$ and, using Proposition 5.1.9, deduce that f is not continuous.

3. Let $f : \mathbb{R} \rightarrow \mathbb{R}$ be given by

$$f(x) = \begin{cases} x, & x \leq 1 \\ x + 2, & x > 1. \end{cases}$$

Is f continuous? (Justify your answer.)

4. Let (X, \mathcal{T}) be the subspace of \mathbb{R} given by $X = [0, 1] \cup [2, 4]$. Define $f : (X, \mathcal{T}) \rightarrow \mathbb{R}$ by

$$f(x) = \begin{cases} 1, & \text{if } x \in [0, 1] \\ 2, & \text{if } x \in [2, 4]. \end{cases}$$

Prove that f is not continuous. (Does this surprise you?)

5. Let (X, \mathcal{T}) and (Y, \mathcal{T}_1) be topological spaces and \mathcal{B}_1 a basis for the topology \mathcal{T}_1 . Show that a map $f : (X, \mathcal{T}) \rightarrow (Y, \mathcal{T}_1)$ is continuous if and only if $f^{-1}(U) \in \mathcal{T}$, for every $U \in \mathcal{B}_1$.
6. Let (X, \mathcal{T}) and (Y, \mathcal{T}_1) be topological spaces and f a mapping of X into Y . If (X, \mathcal{T}) is a discrete space, prove that f is continuous.
7. Let (X, \mathcal{T}) and (Y, \mathcal{T}_1) be topological spaces and f a mapping of X into Y . If (Y, \mathcal{T}_1) is an indiscrete space, prove that f is continuous.
8. Let (X, \mathcal{T}) and (Y, \mathcal{T}_1) be topological spaces and $f : (X, \mathcal{T}) \rightarrow (Y, \mathcal{T}_1)$ a continuous mapping. Let A be a subset of X , \mathcal{T}_2 the induced topology on A , $B = f(A)$, \mathcal{T}_3 the induced topology on B and $g : (A, \mathcal{T}_2) \rightarrow (B, \mathcal{T}_3)$ the restriction of f to A . Prove that g is continuous.

9. Let f be a mapping of a space (X, \mathcal{T}) into a space (Y, \mathcal{T}') . Prove that f is continuous if and only if for each $x \in X$ and each neighbourhood N of $f(x)$ there exists a neighbourhood M of x such that $f(M) \subseteq N$.
10. Let \mathcal{T}_1 and \mathcal{T}_2 be two topologies on a set X . Then \mathcal{T}_1 is said to be a **finer topology** than \mathcal{T}_2 (and \mathcal{T}_2 is said to be a **coarser topology** than \mathcal{T}_1) if $\mathcal{T}_1 \supseteq \mathcal{T}_2$. Prove that
- the Euclidean topology \mathbb{R} is finer than the finite-closed topology on \mathbb{R} ;
 - the identity function $f : (X, \mathcal{T}_1) \rightarrow (X, \mathcal{T}_2)$ is continuous if and only if \mathcal{T}_1 is a finer topology than \mathcal{T}_2 .
11. Let $f : \mathbb{R} \rightarrow \mathbb{R}$ be a continuous function such that $f(q) = 0$ for every rational number q . Prove that $f(x) = 0$ for every $x \in \mathbb{R}$.
12. Let (X, \mathcal{T}) and (Y, \mathcal{T}_1) be topological spaces and $f : (X, \mathcal{T}) \rightarrow (Y, \mathcal{T}_1)$ a continuous map. If f is one-to-one, prove that
- (Y, \mathcal{T}_1) Hausdorff implies (X, \mathcal{T}) Hausdorff.
 - (Y, \mathcal{T}_1) a T_1 -space implies (X, \mathcal{T}) is a T_1 -space.
13. Let (X, \mathcal{T}) and (Y, \mathcal{T}_1) be topological spaces and let f be a mapping of (X, \mathcal{T}) into (Y, \mathcal{T}_1) . Prove that f is continuous if and only if for every subset A of X , $f(\overline{A}) \subseteq \overline{f(A)}$.
- [Hint: Use Proposition 5.1.9.]

5.2 Intermediate Value Theorem

5.2.1 Proposition. Let (X, \mathcal{T}) and (Y, \mathcal{T}_1) be topological spaces and $f : (X, \mathcal{T}) \rightarrow (Y, \mathcal{T}_1)$ surjective and continuous. If (X, \mathcal{T}) is connected, then (Y, \mathcal{T}_1) is connected.

Proof. Suppose (Y, \mathcal{T}_1) is not connected. Then it has a clopen subset U such that $U \neq \emptyset$ and $U \neq Y$. Then $f^{-1}(U)$ is an open set, since f is continuous, and also a closed set, by Proposition 5.1.9; that is, $f^{-1}(U)$ is a clopen subset of X . Now $f^{-1}(U) \neq \emptyset$ as f is surjective and $U \neq \emptyset$. Also $f^{-1}(U) \neq X$, since if it were U would equal Y , by the surjectivity of f . Thus (X, \mathcal{T}) is not connected. This is a contradiction. Therefore (Y, \mathcal{T}_1) is connected. \square

5.2.2 Remarks. (i) The above proposition would be false if the condition “surjective” were dropped. (Find an example of this.)

(ii) Simply put, Proposition 5.2.1 says: **any continuous image of a connected set is connected.**

(iii) Proposition 5.2.1 tells us that if (X, \mathcal{T}) is a connected space and (Y, \mathcal{T}') is not connected (i.e. **disconnected**) then there exists no mapping of (X, \mathcal{T}) onto (Y, \mathcal{T}') which is continuous. For example, while there are an infinite number of mappings of \mathbb{R} onto \mathbb{Q} (or onto \mathbb{Z}), none of them are continuous. Indeed in Exercise Set 5.2 # 10 we observe that the only continuous mappings of \mathbb{R} into \mathbb{Q} (or into \mathbb{Z}) are the constant mappings. \square

The following strengthened version of the notion of connectedness is often useful.

5.2.3 Definition. A topological space (X, \mathcal{T}) is said to be **path-connected** (or **pathwise connected**) if for each pair of distinct points a and b of X there exists a continuous mapping $f : [0, 1] \rightarrow (X, \mathcal{T})$, such that $f(0) = a$ and $f(1) = b$. The mapping f is said to be a **path joining a to b .**

5.2.4 Example. It is readily seen that every interval is path-connected. \square

5.2.5 Example. For each $n \geq 1$, \mathbb{R}^n is path-connected. \square

5.2.6 Proposition. Every path-connected space is connected.

Proof. Let (X, \mathcal{T}) be a path-connected space and suppose that it is not connected.

Then it has a proper non-empty clopen subset U . So there exist a and b such that $a \in U$ and $b \in X \setminus U$. As (X, \mathcal{T}) is path-connected there exists a continuous function $f : [0, 1] \rightarrow (X, \mathcal{T})$ such that $f(0) = a$ and $f(1) = b$.

However, $f^{-1}(U)$ is a clopen subset of $[0, 1]$. As $a \in U$, $0 \in f^{-1}(U)$ and so $f^{-1}(U) \neq \emptyset$. As $b \notin U$, $1 \notin f^{-1}(U)$ and thus $f^{-1}(U) \neq [0, 1]$. Hence $f^{-1}(U)$ is a proper non-empty clopen subset of $[0, 1]$, which contradicts the connectedness of $[0, 1]$.

Consequently (X, \mathcal{T}) is connected. \square

5.2.7 Remark. The converse of Proposition 5.2.6 is false; that is, not every connected space is path-connected. An example of such a space is the following subspace of \mathbb{R}^2 :

$$X = \{(x, y) : y = \sin(1/x), 0 < x \leq 1\} \cup \{(0, y) : -1 \leq y \leq 1\}.$$

[Exercise Set 5.2 #6 shows that X is connected. That X is not path-connected can be seen by showing that there is no path joining $\langle 0, 0 \rangle$ to, say, the point $\langle 1/\pi, 0 \rangle$. Draw a picture and try to convince yourself of this.] □

We can now show that $\mathbb{R} \not\cong \mathbb{R}^2$.

5.2.8 Example. Clearly $\mathbb{R}^2 \setminus \{\langle 0, 0 \rangle\}$ is path-connected and hence, by Proposition 5.2.6, is connected. However $\mathbb{R} \setminus \{a\}$, for any $a \in \mathbb{R}$, is disconnected. Hence $\mathbb{R} \not\cong \mathbb{R}^2$. □

We now present the Weierstrass Intermediate Value Theorem which is a beautiful application of topology to the theory of functions of a real variable. The topological concept crucial to the result is that of connectedness.

5.2.9 Theorem. (Weierstrass Intermediate Value Theorem) Let $f : [a, b] \rightarrow \mathbb{R}$ be continuous and let $f(a) \neq f(b)$. Then for every number p between $f(a)$ and $f(b)$ there is a point $c \in [a, b]$ such that $f(c) = p$.

Proof. As $[a, b]$ is connected and f is continuous, Proposition 5.2.1 says that $f([a, b])$ is connected. By Proposition 4.3.5 this implies that $f([a, b])$ is an interval. Now $f(a)$ and $f(b)$ are in $f([a, b])$. So if p is between $f(a)$ and $f(b)$, $p \in f([a, b])$, that is, $p = f(c)$, for some $c \in [a, b]$. □

5.2.10 Corollary. If $f : [a, b] \rightarrow \mathbb{R}$ is continuous and such that $f(a) > 0$ and $f(b) < 0$, then there exists an $x \in [a, b]$ such that $f(x) = 0$. □

5.2.11 Corollary. (Fixed Point Theorem) Let f be a continuous mapping of $[0, 1]$ into $[0, 1]$. Then there exists a $z \in [0, 1]$ such that $f(z) = z$. (The point z is called a **fixed point**.)

Proof. If $f(0) = 0$ or $f(1) = 1$, the result is obviously true. Thus it suffices to consider the case when $f(0) > 0$ and $f(1) < 1$.

Let $g : [0, 1] \rightarrow \mathbb{R}$ be defined by $g(x) = x - f(x)$. Then g is continuous, $g(0) = -f(0) < 0$, and $g(1) = 1 - f(1) > 0$. Consequently, by Corollary 5.2.10, there exists a $z \in [0, 1]$ such that $g(z) = 0$; that is, $z - f(z) = 0$ or $f(z) = z$. \square

5.2.12 Remark. Corollary 5.2.11 is a special case of a very important theorem called the **Brouwer Fixed Point Theorem** which says that **if you map an n -dimensional cube continuously into itself then there is a fixed point**. [There are many proofs of this theorem, but most depend on methods of algebraic topology. An unsophisticated proof is given on pp. 238–239 of the book “Introduction to Set Theory and Topology”, by K. Kuratowski (Pergamon Press, 1961).]

Exercises 5.2

1. Prove that a continuous image of a path-connected space is path-connected.
2. Let f be a continuous mapping of the interval $[a, b]$ into itself, where a and $b \in \mathbb{R}$ and $a < b$. Prove that there is a fixed point.
3. (i) Give an example which shows that Corollary 5.2.11 would be false if we replaced $[0, 1]$ everywhere by $(0, 1)$.
 - (ii) A topological space (X, \mathcal{T}) is said to have the **fixed point property** if every continuous mapping of (X, \mathcal{T}) into itself has a fixed point. Show that the only intervals having the fixed point property are the closed intervals.
 - (iii) Let X be a set with at least two points. Prove that the discrete space (X, \mathcal{T}) and the indiscrete space (X, \mathcal{T}') do not have the fixed-point property.
 - (iv) Does a space which has the finite-closed topology have the fixed-point property?
 - (v) Prove that if the space (X, \mathcal{T}) has the fixed-point property and (Y, \mathcal{T}_1) is a space homeomorphic to (X, \mathcal{T}) , then (Y, \mathcal{T}_1) has the fixed-point property.

4. Let $\{A_j : j \in J\}$ be a family of connected subspaces of a topological space (X, \mathcal{T}) . If $\bigcap_{j \in J} A_j \neq \emptyset$, show that $\bigcup_{j \in J} A_j$ is connected.
5. Let A be a connected subspace of a topological space (X, \mathcal{T}) . Prove that \overline{A} is also connected. Indeed, show that if $A \subseteq B \subseteq \overline{A}$, then B is connected.
6. (i) Show that the subspace $Y = \{(x, y) : y = \sin(1/x), 0 < x \leq 1\}$ of \mathbb{R}^2 is connected.
[Hint: Use Proposition 5.2.1.]
- (ii) Verify that $\overline{Y} = Y \cup \{(0, y) : -1 \leq y \leq 1\}$
- (iii) Using Exercise 5, observe that \overline{Y} is connected.
7. Let E be the set of all points in \mathbb{R}^2 having both coordinates rational. Prove that the space $\mathbb{R}^2 \setminus E$ is path-connected.
- 8.* Let C be any countable subset of \mathbb{R}^2 . Prove that the space $\mathbb{R}^2 \setminus C$ is path-connected.
9. Let (X, \mathcal{T}) be a topological space and a any point in X . The **component in X of a** , $C_X(a)$, is defined to be the union of all connected subsets of X which contain a . Show that
- (i) $C_X(a)$ is connected. (Use Exercise 4 above.)
- (ii) $C_X(a)$ is the largest connected set containing a .
- (iii) $C_X(a)$ is closed in X . (Use Exercise 5 above.)
10. A topological space (X, \mathcal{T}) is said to be **totally disconnected** if every non-empty connected subset is a singleton set. Prove the following statements.
- (i) (X, \mathcal{T}) is totally disconnected if and only if for each $a \in X$, $C_X(a) = \{a\}$. (See the notation in Exercise 9.)
- (ii) The set \mathbb{Q} of all rational numbers with the usual topology is totally disconnected.
- (iii) If f is a continuous mapping of \mathbb{R} into \mathbb{Q} , prove that there exists a $c \in \mathbb{Q}$ such that $f(x) = c$, for all $x \in \mathbb{R}$.
- (iv) Every subspace of a totally disconnected space is totally disconnected.
- (v) Every countable subspace of \mathbb{R}^2 is totally disconnected.
- (vi) The Sorgenfrey line is totally disconnected.

11. (i) Using Exercise 9, define, in the natural way, the “path-component” of a point in a topological space.
- (ii) Prove that, in any topological space, every path-component is a path-connected space.
- (iii) If (X, \mathcal{T}) is a topological space with the property that every point in X has a neighbourhood which is path-connected, prove that every path-component is an open set. Deduce that every path-component is also a closed set.
- (iv) Using (iii), show that an open subset of \mathbb{R}^2 is connected if and only if it is path-connected.
- 12.* Let A and B be subsets of a topological space (X, \mathcal{T}) . If A and B are both open or both closed, and $A \cup B$ and $A \cap B$ are both connected, show that A and B are connected.
13. A topological space (X, \mathcal{T}) is said to be **zero-dimensional** if there is a basis for the topology consisting of clopen sets. Prove the following statements.
- (i) \mathbb{Q} and \mathbb{P} are zero-dimensional spaces.
- (ii) A subspace of a zero-dimensional space is zero-dimensional.
- (iii) A zero-dimensional Hausdorff space is totally disconnected. (See Exercise 10 above.)
- (iv) Every indiscrete space is zero-dimensional.
- (v) Every discrete space is zero-dimensional.
- (vi) Indiscrete spaces with more than one point are not totally disconnected.
- (vii) A zero-dimensional T_0 -space is Hausdorff.
- (viii)* A subspace of \mathbb{R} is zero-dimensional if and only if it is totally disconnected.
14. Show that every local homeomorphism is a continuous mapping. (See Exercises 4.3#9.)

5.3 Postscript

In this chapter we said that a mapping³ between topological spaces is called “continuous” if it has the property that the inverse image of every open set is an open set. This is an elegant definition and easy to understand. It contrasts with the one we meet in real analysis which was mentioned at the beginning of this section. We have generalized the real analysis definition, not for the sake of generalization, but rather to see what is really going on.

The Weierstrass Intermediate Value Theorem seems intuitively obvious, but we now see it follows from the fact that \mathbb{R} is connected and that any continuous image of a connected space is connected.

We introduced a stronger property than connected, namely path-connected. In many cases it is not sufficient to insist that a space be connected, it must be path-connected. This property plays an important role in algebraic topology.

We shall return to the Brouwer Fixed Point Theorem in due course. It is a powerful theorem. Fixed point theorems play important roles in various branches of mathematics including topology, functional analysis, and differential equations. They are still a topic of research activity today.

In Exercises 5.2 #9 and #10 we met the notions of “component” and “totally disconnected”. Both of these are important for an understanding of connectedness.

³**Warning:** Some books use the terms “mapping” and “map” to mean continuous mapping. We do not.

Chapter 6

Metric Spaces

Introduction

The most important class of topological spaces is the class of metric spaces. Metric spaces provide a rich source of examples in topology. But more than this, most of the applications of topology to analysis are via metric spaces.

6.1 Metric Spaces

6.1.1 Definition. Let X be a non-empty set and d a real-valued function defined on $X \times X$ such that for $a, b \in X$:

(i) $d(a, b) \geq 0$ and $d(a, b) = 0$ if and only if $a = b$,

(ii) $d(a, b) = d(b, a)$ and

(iii) $d(a, c) \leq d(a, b) + d(b, c)$, [the triangle inequality] for all a, b and c in X .

Then d is said to be a **metric** on X , (X, d) is called a **metric space** and $d(a, b)$ is referred to as the **distance** between a and b .

6.1.2 Example. The function $d : \mathbb{R} \times \mathbb{R} \rightarrow \mathbb{R}$ given by

$$d(a, b) = |a - b|, \quad a, b \in \mathbb{R}$$

is a metric on the set \mathbb{R} since

- (i) $|a - b| \geq 0$, for all a and b in \mathbb{R} , and $|a - b| = 0$ if and only if $a = b$,
- (ii) $|a - b| = |b - a|$, and
- (iii) $|a - c| \leq |a - b| + |b - c|$. (Deduce this from $|x + y| \leq |x| + |y|$.)

We call d the **euclidean metric on \mathbb{R}** . □

6.1.3 Example. The function $d : \mathbb{R}^2 \times \mathbb{R}^2 \rightarrow \mathbb{R}$ given by

$$d(\langle a_1, a_2 \rangle, \langle b_1, b_2 \rangle) = \sqrt{(a_1 - b_1)^2 + (a_2 - b_2)^2}$$

is a metric on \mathbb{R}^2 called the **euclidean metric on \mathbb{R}^2** .

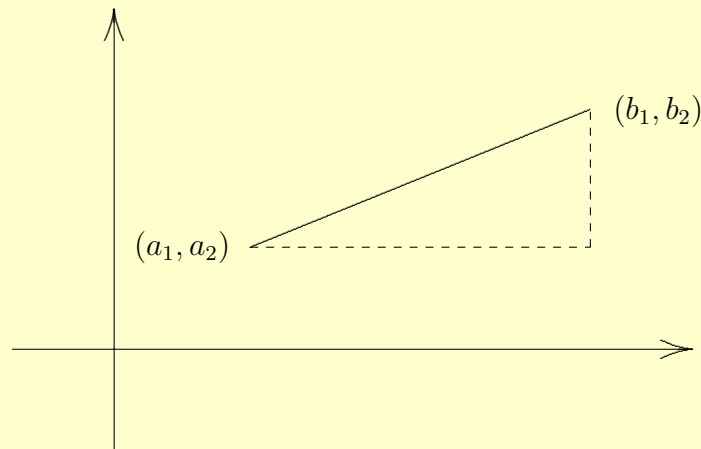

□

6.1.4 Example. Let X be a non-empty set and d the function from $X \times X$ into \mathbb{R} defined by

$$d(a, b) = \begin{cases} 0, & \text{if } a = b \\ 1, & \text{if } a \neq b. \end{cases}$$

Then d is a metric on X and is called the **discrete metric**. □

Many important examples of metric spaces are "function spaces". For these the set X on which we put a metric is a set of functions.

6.1.5 Example. Let $C[0, 1]$ denote the set of continuous functions from $[0, 1]$ into \mathbb{R} . A metric is defined on this set by

$$d(f, g) = \int_0^1 |f(x) - g(x)| dx$$

where f and g are in $C[0, 1]$.

A moment's thought should tell you that $d(f, g)$ is precisely the area of the region which lies between the graphs of the functions and the lines $x = 0$ and $x = 1$, as illustrated below.

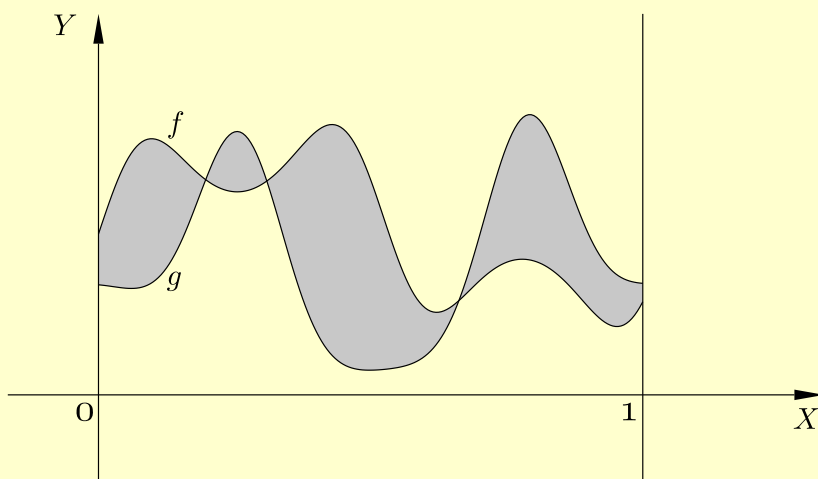

□

6.1.6 Example. Again let $C[0, 1]$ be the set of all continuous functions from $[0, 1]$ into \mathbb{R} . Another metric is defined on $C[0, 1]$ as follows:

$$d^*(f, g) = \sup\{|f(x) - g(x)| : x \in [0, 1]\}.$$

Clearly $d^*(f, g)$ is just the largest vertical gap between the graphs of the functions f and g .

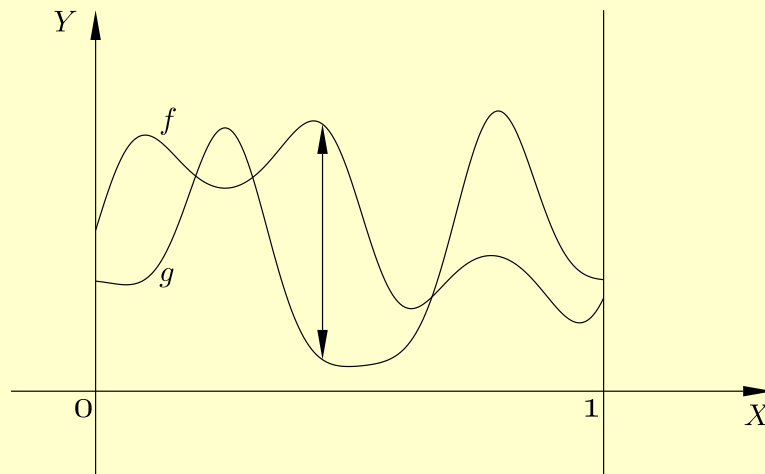

□

6.1.7 Example. We can define another metric on \mathbb{R}^2 by putting

$$d^*(\langle a_1, a_2 \rangle, \langle b_1, b_2 \rangle) = \max\{|a_1 - b_1|, |a_2 - b_2|\}$$

where $\max\{x, y\}$ equals the larger of the two numbers x and y .

□

6.1.8 Example. Yet another metric on \mathbb{R}^2 is given by

$$d_1(\langle a_1, a_2 \rangle, \langle b_1, b_2 \rangle) = |a_1 - b_1| + |a_2 - b_2|.$$

□

A rich source of examples of metric spaces is the family of normed vector spaces.

6.1.9 Example. Let V be a vector space over the field of real or complex numbers. A **norm** $\| \cdot \|$ on V is a map $\| \cdot \| : V \rightarrow \mathbb{R}$ such that for all $a, b \in V$ and λ in the field

$$(i) \quad \| a \| \geq 0 \text{ and } \| a \| = 0 \text{ if and only if } a = 0,$$

$$(ii) \quad \| a + b \| \leq \| a \| + \| b \| \text{ and}$$

$$(iii) \quad \| \lambda a \| = |\lambda| \| a \|.$$

A **normed vector space** $(V, \| \cdot \|)$ is a vector space V with a norm $\| \cdot \|$.

Let $(V, \| \cdot \|)$ be any normed vector space. Then there is a corresponding metric on the set V given by $d(a, b) = \| a - b \|$, for a and b in V .

It is easily checked that d is indeed a metric. So **every normed vector space is also a metric space** in a natural way.

For example, \mathbb{R}^3 is a normed vector space if we put

$$\| \langle x_1, x_2, x_3 \rangle \| = \sqrt{x_1^2 + x_2^2 + x_3^2}, \quad \text{for } x_1, x_2, \text{ and } x_3 \text{ in } \mathbb{R}.$$

So \mathbb{R}^3 becomes a metric space if we put

$$\begin{aligned} d(\langle a_1, b_1, c_1 \rangle, \langle a_2, b_2, c_2 \rangle) &= \| (a_1 - a_2, b_1 - b_2, c_1 - c_2) \| \\ &= \sqrt{(a_1 - a_2)^2 + (b_1 - b_2)^2 + (c_1 - c_2)^2}. \end{aligned}$$

Indeed \mathbb{R}^n , for any positive integer n , is a normed vector space if we put

$$\| \langle x_1, x_2, \dots, x_n \rangle \| = \sqrt{x_1^2 + x_2^2 + \dots + x_n^2}.$$

So \mathbb{R}^n becomes a metric space if we put

$$\begin{aligned} d(\langle a_1, a_2, \dots, a_n \rangle, \langle b_1, b_2, \dots, b_n \rangle) &= \| \langle a_1 - b_1, a_2 - b_2, \dots, a_n - b_n \rangle \| \\ &= \sqrt{(a_1 - b_1)^2 + (a_2 - b_2)^2 + \dots + (a_n - b_n)^2}. \quad \square \end{aligned}$$

In a normed vector space $(N, \| \cdot \|)$ the **open ball with centre a and radius r** is defined to be the set

$$B_r(a) = \{x : x \in V \text{ and } \|x - a\| < r\}.$$

This suggests the following definition for metric spaces:

6.1.10 Definition. Let (X, d) be a metric space and r any positive real number. Then the **open ball about $a \in X$ of radius r** is the set $B_r(a) = \{x : x \in X \text{ and } d(a, x) < r\}$.

6.1.11 Example. In \mathbb{R} with the euclidean metric $B_r(a)$ is the open interval $(a - r, a + r)$. \square

6.1.12 Example. In \mathbb{R}^2 with the euclidean metric, $B_r(a)$ is the open disc with centre a and radius r .

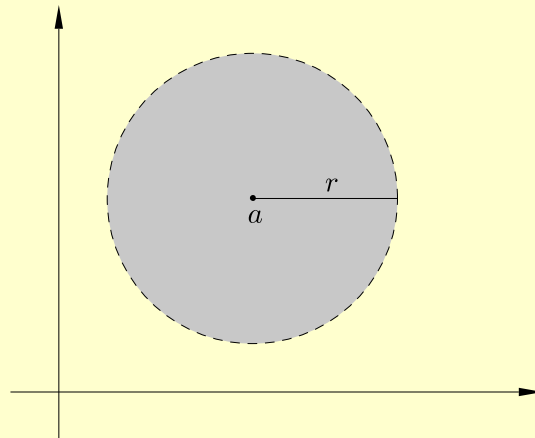
 \square

6.1.13 Example. In \mathbb{R}^2 with the metric d^* given by

$$d^*(\langle a_1, a_2 \rangle, \langle b_1, b_2 \rangle) = \max\{|a_1 - b_1|, |a_2 - b_2|\},$$

the open ball $B_1(\langle 0, 0 \rangle)$ looks like

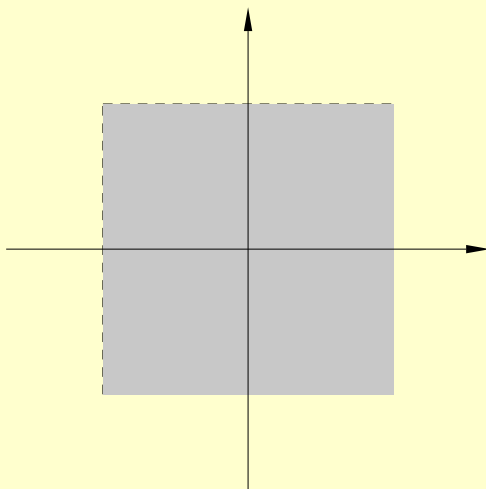

□

6.1.14 Example. In \mathbb{R}^2 with the metric d_1 given by

$$d_1(\langle a_1, a_2 \rangle, \langle b_1, b_2 \rangle) = |a_1 - b_1| + |a_2 - b_2|,$$

the open ball $B_1(\langle 0, 0 \rangle)$ looks like

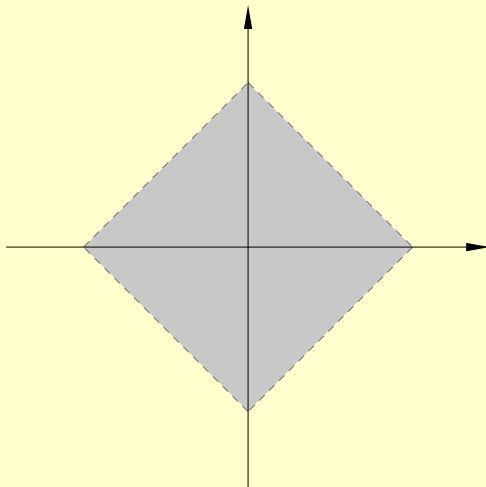

□

The proof of the following Lemma is quite easy (especially if you draw a diagram) and so is left for you to supply.

6.1.15 Lemma. Let (X, d) be a metric space and a and b points of X . Further, let δ_1 and δ_2 be positive real numbers. If $c \in B_{\delta_1}(a) \cap B_{\delta_2}(b)$, then there exists a $\delta > 0$ such that $B_\delta(c) \subseteq B_{\delta_1}(a) \cap B_{\delta_2}(b)$. \square

The next Corollary follows in a now routine way from Lemma 6.1.15.

6.1.16 Corollary. Let (X, d) be a metric space and B_1 and B_2 open balls in (X, d) . Then $B_1 \cap B_2$ is a union of open balls in (X, d) . \square

Finally we are able to link metric spaces with topological spaces.

6.1.17 Proposition. Let (X, d) be a metric space. Then the collection of open balls in (X, d) is a basis for a topology \mathcal{T} on X .

[The topology \mathcal{T} is referred to as **the topology induced by the metric d** , and (X, \mathcal{T}) is called **the induced topological space** or **the corresponding topological space** or the **associated topological space**.]

Proof. This follows from Proposition 2.2.8 and Corollary 6.1.16. \square

6.1.18 Example. If d is the euclidean metric on \mathbb{R} then a basis for the topology \mathcal{T} induced by the metric d is the set of all open balls. But $B_\delta(a) = (a - \delta, a + \delta)$. From this it is readily seen that \mathcal{T} is the euclidean topology on \mathbb{R} . So **the euclidean metric on \mathbb{R} induces the euclidean topology on \mathbb{R}** . \square

6.1.19 Example. From Exercises 2.3 #1 (ii) and Example 6.1.12, it follows that the euclidean metric on the set \mathbb{R}^2 induces the euclidean topology on \mathbb{R}^2 . \square

6.1.20 Example. From Exercises 2.3 #1 (i) and Example 6.1.13 it follows that the metric d^* also induces the euclidean topology on the set \mathbb{R}^2 . \square

It is left as an exercise for you to prove that the metric d_1 of Example 6.1.14 also induces the euclidean topology on \mathbb{R}^2 .

6.1.21 Example. If d is the discrete metric on a set X then for each $x \in X$, $B_{\frac{1}{2}}(x) = \{x\}$. So all the singleton sets are open in the topology \mathcal{T} induced on X by d . Consequently, \mathcal{T} is the discrete topology. \square

We saw in Examples 6.1.19, 6.1.20, and 6.1.14 three different metrics on the same set which induce the same topology.

6.1.22 Definition. Two metrics on a set X are called **equivalent** if they induce the same topology on X .

So the metrics d, d^* , and d_1 , of Examples 6.1.3, 6.1.13, and 6.1.14 on \mathbb{R}^2 are equivalent.

6.1.23 Proposition. Let (X, d) be a metric space and \mathcal{T} the topology induced on X by the metric d . Then a subset U of X is open in (X, \mathcal{T}) if and only if for each $a \in U$ there exists an $\varepsilon > 0$ such that the open ball $B_\varepsilon(a) \subseteq U$.

Proof. Assume that $U \in \mathcal{T}$. Then, by Propositions 2.3.2 and 6.1.17, for any $a \in U$ there exists a point $b \in X$ and a $\delta > 0$ such that

$$a \in B_\delta(b) \subseteq U.$$

Let $\varepsilon = \delta - d(a, b)$. Then it is readily seen that

$$a \in B_\varepsilon(a) \subseteq U.$$

Conversely, assume that U is a subset of X with the property that for each $a \in U$ there exists an $\varepsilon_a > 0$ such that $B_{\varepsilon_a}(a) \subseteq U$. Then, by Proposition 2.3.3, U is an open set. \square

We have seen that every metric on a set X induces a topology \mathcal{T} on the set X . However, we shall now show that not every topology on a set is induced by a metric. First, a definition which you have already met in the exercises. (See Exercises 4.1 #13.)

6.1.24 Definition. A topological space (X, \mathcal{T}) is said to be a **Hausdorff space** (or a **T_2 -space**) if for each pair of distinct points a and b in X , there exist open sets U and V such that $a \in U$, $b \in V$, and $U \cap V = \emptyset$.

Of course \mathbb{R} , \mathbb{R}^2 and all discrete spaces are examples of Hausdorff spaces, while any set with at least 2 elements and which has the indiscrete topology is not a Hausdorff space. With a little thought we see that \mathbb{Z} with the finite-closed topology is also not a Hausdorff space. (Convince yourself of all of these facts.)

6.1.25 Proposition. Let (X, d) be any metric space and \mathcal{T} the topology induced on X by d . Then (X, \mathcal{T}) is a Hausdorff space.

Proof. Let a and b be any points of X , with $a \neq b$. Then $d(a, b) > 0$. Put $\varepsilon = d(a, b)$. Consider the open balls $B_{\varepsilon/2}(a)$ and $B_{\varepsilon/2}(b)$. Then these are open sets in (X, \mathcal{T}) , $a \in B_{\varepsilon/2}(a)$, and $b \in B_{\varepsilon/2}(b)$. So to show \mathcal{T} is Hausdorff we have to prove only that $B_{\varepsilon/2}(a) \cap B_{\varepsilon/2}(b) = \emptyset$.

Suppose $x \in B_{\varepsilon/2}(a) \cap B_{\varepsilon/2}(b)$. Then $d(x, a) < \frac{\varepsilon}{2}$ and $d(x, b) < \frac{\varepsilon}{2}$. Hence

$$\begin{aligned} d(a, b) &\leq d(a, x) + d(x, b) \\ &< \frac{\varepsilon}{2} + \frac{\varepsilon}{2} = \varepsilon. \end{aligned}$$

This says $d(a, b) < \varepsilon$, which is false. Consequently there exists no x in $B_{\varepsilon/2}(a) \cap B_{\varepsilon/2}(b)$; that is, $B_{\varepsilon/2}(a) \cap B_{\varepsilon/2}(b) = \emptyset$, as required. \square

6.1.26 Remark. Putting Proposition 6.1.25 together with the comments which preceded it, we see that an indiscrete space with at least two points has a topology which is not induced by any metric. Also \mathbb{Z} with the finite-closed topology \mathcal{T} is such that \mathcal{T} is not induced by any metric on \mathbb{Z} . \square

6.1.27 Definition. A space (X, \mathcal{T}) is said to be **metrizable** if there exists a metric d on the set X with the property that \mathcal{T} is the topology induced by d .

So, for example, the set \mathbb{Z} with the finite-closed topology is not a metrizable space.

Warning. One should not be misled by Proposition 6.1.25 into thinking that every Hausdorff space is metrizable. Later on we shall be able to produce (using infinite products) examples of Hausdorff spaces which are not metrizable. [Metrizability of topological spaces is quite a technical topic. For necessary and sufficient conditions for metrizability see Theorem 9.1, page 195, of the book Dugundji [59].]

Exercises 6.1

1. Prove that the metric d_1 of Example 6.1.8 induces the euclidean topology on \mathbb{R}^2 .
2. Let d be a metric on a non-empty set X .
 - (i) Show that the function e defined by $e(a, b) = \min\{1, d(a, b)\}$ where $a, b \in X$, is also a metric on X .
 - (ii) Prove that d and e are equivalent metrics.
 - (iii) A metric space (X, d) is said to be **bounded**, and d is said to be a **bounded metric**, if there exists a positive real number M such that $d(x, y) < M$, for all $x, y \in X$. Using (ii) deduce that every metric is equivalent to a bounded metric.
3. (i) Let d be a metric on a non-empty set X . Show that the function e defined by

$$e(a, b) = \frac{d(a, b)}{1 + d(a, b)}$$

where $a, b \in X$, is also a metric on X .

- (ii) Prove that d and e are equivalent metrics.

4. Let d_1 and d_2 be metrics on sets X and Y respectively. Prove that

(i) d is a metric on $X \times Y$, where

$$d(\langle x_1, y_1 \rangle, \langle x_2, y_2 \rangle) = \max\{d_1(x_1, x_2), d_2(y_1, y_2)\}.$$

(ii) e is a metric on $X \times Y$, where

$$e(\langle x_1, y_1 \rangle, \langle x_2, y_2 \rangle) = d_1(x_1, x_2) + d_2(y_1, y_2).$$

(iii) d and e are equivalent metrics.

5. Let (X, d) be a metric space and \mathcal{T} the corresponding topology on X . Fix $a \in X$. Prove that the map $f : (X, \mathcal{T}) \rightarrow \mathbb{R}$ defined by $f(x) = d(a, x)$ is continuous.

6. Let (X, d) be a metric space and \mathcal{T} the topology induced on X by d . Let Y be a subset of X , d_1 the metric on Y obtained by restricting d ; that is, $d_1(a, b) = d(a, b)$ for all a and b in Y . If \mathcal{T}_1 is the topology induced on Y by d_1 and \mathcal{T}_2 is the subspace topology on Y (induced by \mathcal{T} on X), prove that $\mathcal{T}_1 = \mathcal{T}_2$. [This shows that every subspace of a metrizable space is metrizable.]

7. (i) Let ℓ_1 be the set of all sequences of real numbers

$$x = (x_1, x_2, \dots, x_n, \dots)$$

with the property that the series $\sum_{n=1}^{\infty} |x_n|$ is convergent. If we define

$$d_1(x, y) = \sum_{n=1}^{\infty} |x_n - y_n|$$

for all x and y in ℓ_1 , prove that (ℓ_1, d_1) is a metric space.

- (ii) Let ℓ_2 be the set of all sequences of real numbers

$$x = (x_1, x_2, \dots, x_n, \dots)$$

with the property that the series $\sum_{n=1}^{\infty} x_n^2$ is convergent. If we define

$$d_2(x, y) = \left(\sum_{n=1}^{\infty} |x_n - y_n|^2 \right)^{\frac{1}{2}}$$

for all x and y in ℓ_2 , prove that (ℓ_2, d_2) is a metric space.

- (iii) Let ℓ_{∞} denote the set of bounded sequences of real numbers $x = (x_1, x_2, \dots, x_n, \dots)$.

If we define

$$d_{\infty}(x, y) = \sup\{|x_n - y_n| : n \in \mathbb{N}\}$$

where $x, y \in \ell_{\infty}$, prove that $(\ell_{\infty}, d_{\infty})$ is a metric space.

- (iv) Let c_0 be the subset of ℓ_{∞} consisting of all those sequences which converge to zero and let d_0 be the metric on c_0 obtained by restricting the metric d_{∞} on ℓ_{∞} as in Exercise 6. Prove that c_0 is a closed subset of $(\ell_{\infty}, d_{\infty})$.

- (v) Prove that each of the spaces (ℓ_1, d_1) , (ℓ_2, d_2) , and (c_0, d_0) is a separable space.

- (vi)* Is $(\ell_{\infty}, d_{\infty})$ a separable space?

- (vii) Show that each of the above metric spaces is a normed vector space in a natural way.

8. Let f be a continuous mapping of a metrizable space (X, \mathcal{T}) onto a topological space (Y, \mathcal{T}_1) . Is (Y, \mathcal{T}_1) necessarily metrizable? (Justify your answer.)

9. A topological space (X, \mathcal{T}) is said to be a **normal space** if for each pair of disjoint closed sets A and B , there exist open sets U and V such that $A \subseteq U$, $B \subseteq V$, and $U \cap V = \emptyset$. Prove that

(i) Every metrizable space is a normal space.

(ii) Every space which is both a T_1 -space and a normal space is a Hausdorff space. [A normal space which is also Hausdorff is called a **T_4 -space**.]

10. Let (X, d) and (Y, d_1) be metric spaces. Then (X, d) is said to be **isometric** to (Y, d_1) if there exists a surjective mapping $f : (X, d) \rightarrow (Y, d_1)$ such that for all x_1 and x_2 in X ,

$$d(x_1, x_2) = d_1(f(x_1), f(x_2)).$$

Such a mapping f is said to be an **isometry**. Prove that every isometry is a homeomorphism of the corresponding topological spaces. (So **isometric metric spaces are homeomorphic!**)

11. A topological space (X, \mathcal{T}) is said to satisfy the **first axiom of countability** or be **first countable** if for each $x \in X$ there exists a countable family $\{U_i(x)\}$ of open sets containing x with the property that every open set V containing x has (at least) one of the $U_i(x)$ as a subset. The countable family $\{U_i(x)\}$ is said to be a **countable base** at x . Prove the following:

(i) Every metrizable space satisfies the first axiom of countability.

(ii) Every topological space satisfying the second axiom of countability also satisfies the first axiom of countability.

12. Let X be the set $(\mathbb{R} \setminus \mathbb{N}) \cup \{1\}$. Define a function $f : \mathbb{R} \rightarrow X$ by

$$f(x) = \begin{cases} x, & \text{if } x \in \mathbb{R} \setminus \mathbb{N} \\ 1, & \text{if } x \in \mathbb{N}. \end{cases}$$

Further, define a topology \mathcal{T} on X by

$$\mathcal{T} = \{U : U \subseteq X \text{ and } f^{-1}(U) \text{ is open in the euclidean topology on } \mathbb{R}.\}$$

Prove the following:

- (i) f is continuous.
- (ii) Every open neighbourhood of 1 in (X, \mathcal{T}) is of the form $(U \setminus \mathbb{N}) \cup \{1\}$, where U is open in \mathbb{R} .
- (iii) (X, \mathcal{T}) is not first countable.

[Hint. Suppose $(U_1 \setminus \mathbb{N}) \cup \{1\}, (U_2 \setminus \mathbb{N}) \cup \{1\}, \dots, (U_n \setminus \mathbb{N}) \cup \{1\}, \dots$ is a countable base at 1. Show that for each positive integer n , we can choose $x_n \in U_n \setminus \mathbb{N}$ such that $x_n > n$. Verify that the set $U = \mathbb{R} \setminus \bigcup_{n=1}^{\infty} \{x_n\}$ is open in \mathbb{R} . Deduce that $V = (U \setminus \mathbb{N}) \cup \{1\}$ is an open neighbourhood of 1 which contains none of the sets $(U_n \setminus \mathbb{N}) \cup \{1\}$, which is a contradiction. So (X, \mathcal{T}) is not first countable.]

- (iv) (X, \mathcal{T}) is a Hausdorff space.
- (v) A Hausdorff continuous image of \mathbb{R} is not necessarily first countable.

13. A metric space (X, d) is said to be **totally bounded** if for each $\varepsilon > 0$, there exist x_1, x_2, \dots, x_n in X , such that $X = \bigcup_{i=1}^n B_\varepsilon(x_i)$; that is, X can be covered by a finite number of open balls of radius ε .
- (i) Show that every totally bounded metric space is a bounded metric space. (See Exercise 2 above.)
 - (ii) Prove that \mathbb{R} with the euclidean metric is not totally bounded, but for each $a, b \in \mathbb{R}$ with $a < b$, the closed interval $[a, b]$ is totally bounded.
 - (iii) Let (Y, d) be a subspace of the metric space (X, d_1) with the induced metric. If (X, d_1) is totally bounded, then (Y, d) is totally bounded; that is, **every subspace of a totally bounded metric space is totally bounded**.
 [Hint. Assume $X = \bigcup_{i=1}^n B_\varepsilon(x_i)$. If $y_i \in B_\varepsilon(x_i) \cap Y$, then by the triangle inequality $B_\varepsilon(x_i) \subseteq B_{2\varepsilon}(y_i)$.]
 - (iv) From (iii) and (ii) deduce that the totally bounded metric space $(0, 1)$ is homeomorphic to \mathbb{R} which is not totally bounded. Thus “totally bounded” is not a topological property.
 - (v) From (iii) and (ii) deduce that for each $n > 1$, \mathbb{R}^n with the euclidean metric is not totally bounded.
 - (vi) Noting that for each $a, b \in \mathbb{R}$, the closed interval is totally bounded, show that a metric subspace of \mathbb{R} is bounded if and only if it is totally bounded.
 - (vii) Show that for each $n > 1$, a metric subspace of \mathbb{R}^n is bounded if and only if it is totally bounded.
14. Show that every totally bounded metric space is separable. (See Exercise 13 above and Exercises 3.2#4.)

15. A topological space (X, \mathcal{T}) is said to be **locally euclidean** if there exists a positive integer n such that each point $x \in X$ has an open neighbourhood homeomorphic to an open ball about 0 in \mathbb{R}^n with the euclidean metric. A Hausdorff locally euclidean space is said to be a **topological manifold**.¹
- (i) Prove that every non-trivial interval is locally euclidean.
 - (ii) Let \mathbb{T} be the subset of the complex plane consisting of those complex numbers of modulus one. Identify the complex plane with \mathbb{R}^2 and let \mathbb{T} have the subspace topology. Show that the space \mathbb{T} is locally euclidean.
 - (iii) Show that every topological space locally homeomorphic to \mathbb{R}^n , for any positive integer n , is locally euclidean.
 - (iv)* Find an example of a locally euclidean space which is not a topological manifold.

¹There are different definitions of topological manifold in the literature (cf. Kunen and Vaughan [123]). In particular some definitions require the space to be connected – what we call a **connected manifold** – and older definitions require the space to be metrizable. A Hausdorff space in which each point has an open neighbourhood homeomorphic either to \mathbb{R}^n or to the closed half-space $\{ \langle x_1, x_2, \dots, x_n \rangle : x_i \geq 0, i = 1, 2, \dots, n \}$ of \mathbb{R}^n , for some positive integer n , is said to be a **topological manifold with boundary**.

6.2 Convergence of Sequences

You are familiar with the notion of a convergent sequence of real numbers. It is defined as follows. The sequence $x_1, x_2, \dots, x_n, \dots$ of real numbers is said to **converge** to the real number x if given any $\varepsilon > 0$ there exists an integer n_0 such that for all $n \geq n_0$, $|x_n - x| < \varepsilon$.

It is obvious how this definition can be extended from \mathbb{R} with the euclidean metric to any metric space.

6.2.1 Definitions. Let (X, d) be a metric space and x_1, \dots, x_n, \dots a sequence of points in X . Then the sequence is said to **converge to** $x \in X$ if given any $\varepsilon > 0$ there exists an integer n_0 such that for all $n \geq n_0$, $d(x, x_n) < \varepsilon$. This is denoted by $x_n \rightarrow x$. The sequence $y_1, y_2, \dots, y_n, \dots$ of points in (X, d) is said to be **convergent** if there exist a point $y \in X$ such that $y_n \rightarrow y$.

The next proposition is easily proved, so its proof is left as an exercise.

6.2.2 Proposition. Let $x_1, x_2, \dots, x_n, \dots$ be a sequence of points in a metric space (X, d) . Further, let x and y be points in (X, d) such that $x_n \rightarrow x$ and $x_n \rightarrow y$. Then $x = y$. \square

The following proposition tells us the surprising fact that the topology of a metric space can be described entirely in terms of its convergent sequences.

6.2.3 Proposition. Let (X, d) be a metric space. A subset A of X is closed in (X, d) if and only if every convergent sequence of points in A converges to a point in A . (In other words, A is closed in (X, d) if and only if $a_n \rightarrow x$, where $x \in X$ and $a_n \in A$ for all n , implies $x \in A$.)

Proof. Assume that A is closed in (X, d) and let $a_n \rightarrow x$, where $a_n \in A$ for all positive integers n . Suppose that $x \in X \setminus A$. Then, as $X \setminus A$ is an open set containing x , there exists an open ball $B_\varepsilon(x)$ such that $x \in B_\varepsilon(x) \subseteq X \setminus A$. Noting that each $a_n \in A$, this implies that $d(x, a_n) > \varepsilon$ for each n . Hence the sequence $a_1, a_2, \dots, a_n, \dots$ does not converge to x . This is a contradiction. So $x \in A$, as required.

Conversely, assume that every convergent sequence of points in A converges to a point of A . Suppose that $X \setminus A$ is not open. Then there exists a point $y \in X \setminus A$ such that for each $\varepsilon > 0$, $B_\varepsilon(y) \cap A \neq \emptyset$. For each positive integer n , let x_n be any point in $B_{1/n}(y) \cap A$. Then we claim that $x_n \rightarrow y$. To see this let ε be any positive real number, and n_0 any integer greater than $1/\varepsilon$. Then for each $n \geq n_0$,

$$x_n \in B_{1/n}(y) \subseteq B_{1/n_0}(y) \subseteq B_\varepsilon(y).$$

So $x_n \rightarrow y$ and, by our assumption, $y \in X \setminus A$. This is a contradiction and so $X \setminus A$ is open and thus A is closed in (X, d) . □

Having seen that the topology of a metric space can be described in terms of convergent sequences, we should not be surprised that continuous functions can also be so described.

6.2.4 Proposition. Let (X, d) and (Y, d_1) be metric spaces and f a mapping of X into Y . Let \mathcal{T} and \mathcal{T}_1 be the topologies determined by d and d_1 , respectively. Then $f : (X, \mathcal{T}) \rightarrow (Y, \mathcal{T}_1)$ is continuous if and only if $x_n \rightarrow x \Rightarrow f(x_n) \rightarrow f(x)$; that is, if $x_1, x_2, \dots, x_n, \dots$ is a sequence of points in (X, d) converging to x , then the sequence of points $f(x_1), f(x_2), \dots, f(x_n), \dots$ in (Y, d_1) converges to $f(x)$.

Proof. Assume that $x_n \rightarrow x \Rightarrow f(x_n) \rightarrow f(x)$. To verify that f is continuous it suffices to show that the inverse image of every closed set in (Y, \mathcal{T}_1) is closed in (X, \mathcal{T}) . So let A be closed in (Y, \mathcal{T}_1) . Let $x_1, x_2, \dots, x_n, \dots$ be a sequence of points in $f^{-1}(A)$ convergent to a point $x \in X$. As $x_n \rightarrow x$, $f(x_n) \rightarrow f(x)$. But since each $f(x_n) \in A$ and A is closed, Proposition 6.2.3 then implies that $f(x) \in A$. Thus $x \in f^{-1}(A)$. So we have shown that every convergent sequence of points from $f^{-1}(A)$ converges to a point of $f^{-1}(A)$. Thus $f^{-1}(A)$ is closed, and hence f is continuous.

Conversely, let f be continuous and $x_n \rightarrow x$. Let ε be any positive real number. Then the open ball $B_\varepsilon(f(x))$ is an open set in (Y, \mathcal{T}_1) . Therefore $f^{-1}(B_\varepsilon(f(x)))$ is an open set in (X, \mathcal{T}) and it contains x . Therefore there exists a $\delta > 0$ such that

$$x \in B_\delta(x) \subseteq f^{-1}(B_\varepsilon(f(x))).$$

As $x_n \rightarrow x$, there exists a positive integer n_0 such that for all $n \geq n_0$, $x_n \in B_\delta(x)$. Therefore

$$f(x_n) \in f(B_\delta(x)) \subseteq B_\varepsilon(f(x)), \text{ for all } n \geq n_0.$$

Thus $f(x_n) \rightarrow f(x)$. □

The corollary below is easily deduced from Proposition 6.2.4.

6.2.5 Corollary. Let (X, d) and (Y, d_1) be metric spaces, f a mapping of X into Y , and \mathcal{T} and \mathcal{T}_1 the topologies determined by d and d_1 , respectively. Then $f : (X, \mathcal{T}) \rightarrow (Y, \mathcal{T}_1)$ is continuous if and only if for each $x_0 \in X$ and $\varepsilon > 0$, there exists a $\delta > 0$ such that $x \in X$ and $d(x, x_0) < \delta \Rightarrow d_1(f(x), f(x_0)) < \varepsilon$. □

Exercises 6.2

1. Let $C[0, 1]$ and d be as in Example 6.1.5. Define a sequence of functions $f_1, f_2, \dots, f_n, \dots$ in $(C[0, 1], d)$ by

$$f_n(x) = \frac{\sin(nx)}{n}, \quad n = 1, 2, \dots, \quad x \in [0, 1].$$

Verify that $f_n \rightarrow f_0$, where $f_0(x) = 0$, for all $x \in [0, 1]$.

2. Let (X, d) be a metric space and $x_1, x_2, \dots, x_n, \dots$ a sequence such that $x_n \rightarrow x$ and $x_n \rightarrow y$. Prove that $x = y$.

3. (i) Let (X, d) be a metric space, \mathcal{T} the induced topology on X , and $x_1, x_2, \dots, x_n, \dots$ a sequence of points in X . Prove that $x_n \rightarrow x$ if and only if for every open set $U \ni x$, there exists a positive integer n_0 such that $x_n \in U$ for all $n \geq n_0$.

(ii) Let X be a set and d and d_1 equivalent metrics on X . Deduce from (i) that if $x_n \rightarrow x$ in (X, d) , then $x_n \rightarrow x$ in (X, d_1) .

4. Write out a proof of Corollary 6.2.5.

5. Let (X, \mathcal{T}) be a topological space and let $x_1, x_2, \dots, x_n, \dots$ be a sequence of points in X . We say that $x_n \rightarrow x$ if for each open set $U \ni x$ there exists a positive integer n_0 , such that $x_n \in U$ for all $n \geq n_0$. Find an example of a topological space and a sequence such that $x_n \rightarrow x$ and $x_n \rightarrow y$ but $x \neq y$.

6. (i) Let (X, d) be a metric space and $x_n \rightarrow x$ where each $x_n \in X$ and $x \in X$. Let A be the subset of X which consists of x and all of the points x_n . Prove that A is closed in (X, d) .

(ii) Deduce from (i) that the set $\{2\} \cup \{2 - \frac{1}{n} : n = 1, 2, \dots\}$ is closed in \mathbb{R} .

(iii) Verify that the set $\{2 - \frac{1}{n} : n = 1, 2, \dots\}$ is not closed in \mathbb{R} .

7. (i) Let d_1, d_2, \dots, d_m be metrics on a set X and a_1, a_2, \dots, a_m positive real numbers. Prove that d is a metric on X , where d is defined by

$$d(x, y) = \sum_{i=1}^m a_i d_i(x, y), \text{ for all } x, y \in X.$$

- (ii) If $x \in X$ and $x_1, x_2, \dots, x_n, \dots$ is a sequence of points in X such that $x_n \rightarrow x$ in each metric space (X, d_i) prove that $x_n \rightarrow x$ in the metric space (X, d) .
8. Let X, Y, d_1, d_2 and d be as in Exercises 6.1 #4. If $x_n \rightarrow x$ in (X, d_1) and $y_n \rightarrow y$ in (Y, d_2) , prove that

$$\langle x_n, y_n \rangle \rightarrow \langle x, y \rangle \text{ in } (X \times Y, d).$$

9. Let A and B be non-empty sets in a metric space (X, d) . Define

$$\rho(A, B) = \inf\{d(a, b) : a \in A, b \in B\}.$$

$[\rho(A, B)$ is referred to as the **distance between the sets A and B .**]

- (i) If S is any non-empty subset of (X, d) , prove that $\bar{S} = \{x : x \in X \text{ and } \rho(\{x\}, S) = 0\}$.
- (ii) If S is any non-empty subset of (X, d) then the function $f : (X, d) \rightarrow \mathbb{R}$ defined by

$$f(x) = \rho(\{x\}, S), \quad x \in X$$

is continuous.

10. (i) For each positive integer n let f_n be a continuous function of $[0, 1]$ into itself and let $a \in [0, 1]$ be such that $f_n(a) = a$, for all n . Further let f be a continuous function of $[0, 1]$ into itself. If $f_n \rightarrow f$ in $(C[0, 1], d^*)$ where d^* is the metric of Example 6.1.6, prove that a is also a fixed point of f .
- (ii) Show that (i) would be false if d^* were replaced by the metric d , of Example 6.1.5.

6.3 Completeness

6.3.1 Definition. A sequence $x_1, x_2, \dots, x_n, \dots$ of points in a metric space (X, d) is **Cauchy sequence** if given any real number $\varepsilon > 0$, there exists a positive integer n_0 , such that for all integers $m \geq n_0$ and $n \geq n_0$, $d(x_m, x_n) < \varepsilon$.

6.3.2 Proposition. Let (X, d) be a metric space and $x_1, x_2, \dots, x_n, \dots$ a sequence of points in (X, d) . If there exists a point $a \in X$, such that the sequence converges to a , that is, $x_n \rightarrow a$, then the sequence is a Cauchy sequence.

Proof. Let ε be any positive real number. Put $\delta = \varepsilon/2$. As $x_n \rightarrow a$, there exists a positive integer n_0 , such that for all $n > n_0$, $d(x_n, a) < \delta$.

So let $m > n_0$ and $n > n_0$. Then $d(x_n, a) < \delta$ and $d(x_m, a) < \delta$.

By the triangle inequality for metrics,

$$\begin{aligned} d(x_m, x_n) &\leq d(x_m, a) + d(x_n, a) \\ &< \delta + \delta \\ &= \varepsilon \end{aligned}$$

and so the sequence is indeed a Cauchy sequence. \square

This naturally leads us to think about the converse statement and to ask if every Cauchy sequence is a convergent sequence. The following example shows that this is not true.

6.3.3 Example. Consider the open interval $(0, 1)$ with the euclidean metric d . It is clear that the sequence $0.1, 0.01, 0.001, 0.0001, \dots$ is a Cauchy sequence but it does not converge to any point in $(0, 1)$. \square

6.3.4 Definition. A metric space (X, d) is said to be **complete** if every Cauchy sequence in (X, d) converges to a point in (X, d) .

We immediately see from Example 6.3.3 that the unit interval $(0, 1)$ with the euclidean metric is not a complete metric space. On the other hand, if X is any finite set and d is the discrete metric on X , then obviously (X, d) is a complete metric space.

We shall show that \mathbb{R} with the euclidean metric is a complete metric space. First we need to do some preparation.

As a shorthand, we shall denote the sequence $x_1, x_2, \dots, x_n, \dots$, by $\{x_n\}$.

6.3.5 Definition. If $\{x_n\}$ is any sequence, then the sequence x_{n_1}, x_{n_2}, \dots is said to be a **subsequence** if $n_1 < n_2 < n_3 < \dots$

6.3.6 Definitions. Let $\{x_n\}$ be a sequence in \mathbb{R} . Then it is said to be an **increasing sequence** if $x_n \leq x_{n+1}$, for all $n \in \mathbb{N}$. It is said to be a **decreasing sequence** if $x_n \geq x_{n+1}$, for all $n \in \mathbb{N}$. A sequence which is either increasing or decreasing is said to be **monotonic**.

Most sequences are of course neither increasing nor decreasing.

6.3.7 Definition. Let $\{x_n\}$ be a sequence in \mathbb{R} . Then $n_0 \in \mathbb{N}$ is said to be a **peak point** if $x_n \leq x_{n_0}$, for every $n \geq n_0$.

6.3.8 Lemma. Let $\{x_n\}$ be any sequence in \mathbb{R} . Then it has a monotonic subsequence.

Proof. Assume first that the sequence $\{x_n\}$ has an infinite number of peak points. Then choose a subsequence $\{x_{n_k}\}$, where each n_k is a peak point. This implies, in particular, that $x_{n_k} \geq x_{n_{k+1}}$, for each $k \in \mathbb{N}$; that is, $\{x_{n_k}\}$ is a decreasing subsequence of $\{x_n\}$.

Assume then that there are only a finite number of peak points. So there exists an integer N , such that there are no peak points $n > N$.

Choose any $n_1 > N$. Then it is not a peak point. So there is an $n_2 > n_1$ with $x_{n_2} > x_{n_1}$. Now $n_2 > N$ and so it too is not a peak point. Hence there is an $n_3 > n_2$, with $x_{n_3} > x_{n_2}$. Continuing in this way (by mathematical induction), we produce a subsequence $\{x_{n_k}\}$ of $\{x_n\}$ with $x_{n_k} < x_{n_{k+1}}$, for all $k \in \mathbb{N}$; that is, $\{x_{n_k}\}$ is an increasing subsequence of $\{x_n\}$. This completes the proof of the Lemma. \square

6.3.9 Proposition. Let $\{x_n\}$ be a monotonic sequence in \mathbb{R} with the euclidean metric. Then $\{x_n\}$ converges to a point in \mathbb{R} if and only if it is bounded.

Proof. Recall that “bounded” was defined in Remark 3.3.1.

Clearly if $\{x_n\}$ is unbounded, then it does not converge.

Assume then that $\{x_n\}$ is an increasing sequence which is bounded. By the Least Upper Bound Axiom, there is a least upper bound L of the set $\{x_n : n \in \mathbb{N}\}$. If ε is any positive real number, then there exists a positive integer N such that $d(x_N, L) < \varepsilon$; indeed, $x_N > L - \varepsilon$.

But as $\{x_n\}$ is an increasing sequence and L is an upper bound, we have

$$L - \varepsilon < x_n < L, \quad \text{for all } n > N.$$

That is $x_n \rightarrow L$. The case that $\{x_n\}$ is a decreasing sequence which is bounded is proved in an analogous fashion, which completes the proof. \square

As a corollary to Lemma 6.3.8 and Proposition 6.3.9, we obtain immediately the following:

6.3.10 Theorem. (Bolzano-Weierstrass Theorem) Every bounded sequence in \mathbb{R} with the euclidean metric has a convergent subsequence. \square

At long last we are able to prove that \mathbb{R} with the euclidean metric is a complete metric space.

6.3.11 Corollary. The metric space \mathbb{R} with the euclidean metric is a complete metric space.

Proof. Let $\{x_n\}$ be any Cauchy sequence in (\mathbb{R}, d) .

If we show that this arbitrary Cauchy sequence converges, we shall have shown that the metric space is complete. The first step will be to show that this sequence is bounded.

As $\{x_n\}$ is a Cauchy sequence, there exists a positive integer N , such that for any $n \geq N$ and $m \geq N$, $d(x_n, x_m) < 1$; that is, $|x_n - x_m| < 1$. Put $M = |x_1| + |x_2| + \cdots + |x_N| + 1$. Then $|x_n| < M$, for all $n \in \mathbb{N}$; that is, the sequence $\{x_n\}$ is bounded.

So by the Bolzano-Weierstrass Theorem 6.3.10, this sequence has a convergent subsequence; that is, there is an $a \in \mathbb{R}$ and a subsequence $\{x_{n_k}\}$ with $x_{n_k} \rightarrow a$.

We shall show that not only does the subsequence converge to a , but also that the sequence $\{x_n\}$ itself converges to a .

Let ε be any positive real number. As $\{x_n\}$ is a Cauchy sequence, there exists a positive integer N_0 such that

$$|x_n - x_m| < \frac{\varepsilon}{2}, \quad \text{for all } m \geq N_0 \text{ and } n \geq N_0.$$

Since $x_{n_k} \rightarrow a$, there exists a positive integer N_1 , such that

$$|x_{n_k} - a| < \frac{\varepsilon}{2}, \quad \text{for all } n_k \geq N_1.$$

So if we choose $N_2 = \max\{N_0, N_1\}$, combining the above two inequalities yields

$$\begin{aligned} |x_n - a| &\leq |x_n - x_{n_k}| + |x_{n_k} - a| \\ &< \frac{\varepsilon}{2} + \frac{\varepsilon}{2}, \quad \text{for } n > N_2 \text{ and } n_k > N_2 \\ &= \varepsilon. \end{aligned}$$

Hence $x_n \rightarrow a$, which completes the proof of the Corollary. \square

6.3.12 Corollary. For each positive integer m , the metric space \mathbb{R}^m with the euclidean metric is a complete metric space.

Proof. See Exercises 6.3#4. □

6.3.13 Proposition. Let (X, d) be a metric space, Y a subset of X , and d_1 the metric induced on Y by d .

- (i) If (X, d) is a complete metric space and Y is a closed subspace of (X, d) , then (Y, d_1) is a complete metric space.
- (ii) If (Y, d_1) is a complete metric space, then Y is a closed subspace of (X, d) .

Proof. See Exercises 6.3#5. □

6.3.14 Remark. Example 6.3.3 showed that $(0, 1)$ with the euclidean metric is not a complete metric space. However, Corollary 6.3.11 showed that \mathbb{R} with the euclidean metric is a complete metric space. And we know that the topological spaces $(0, 1)$ and \mathbb{R} are homeomorphic. So completeness is not preserved by homeomorphism and so is not a topological property.

6.3.15 Definition. A topological space (X, \mathcal{T}) is said to be **completely metrizable** if there exists a metric d on X such that \mathcal{T} is the topology on X determined by d and (X, d) is a complete metric space.

6.3.16 Remark. Note that being completely metrizable is indeed a topological property. Further, it is easy to verify (see Exercises 6.3#7) that every discrete space and every interval of \mathbb{R} with the induced topology is completely metrizable. So for $a, b \in \mathbb{R}$ with $a < b$, the topological spaces \mathbb{R} , $[a, b]$, (a, b) , $[a, b)$, $(a, b]$, $(-\infty, a)$, $(-\infty, a]$, (a, ∞) , $[a, \infty)$, and $\{a\}$ with their induced topologies are all completely metrizable. Somewhat surprisingly we shall see later that even the space \mathbb{P} of all irrational numbers with its induced topology is completely metrizable. Also as $(0, 1)$ is a completely metrizable subspace of \mathbb{R} which is not a closed subset, we see that Proposition 6.3.13(ii) would not be true if complete metric were replaced by completely metrizable. \square

6.3.17 Definition. A topological space is said to be **separable** if it has a countable dense subset.

It was seen in Exercises 3.2#4 that \mathbb{R} and every countable topological space is a separable space. Other examples are given in Exercises 6.1#7.

6.3.18 Definition. A topological space (X, \mathcal{T}) is said to be a **Polish space** if it is separable and completely metrizable.

It is clear that \mathbb{R} is a Polish space. By Exercises 6.3#6, \mathbb{R}^n is a Polish space, for each positive integer n .

6.3.19 Definition. A topological space (X, \mathcal{T}) is said to be a **Souslin space** if it is Hausdorff and a continuous image of a Polish space. If A is a subset of a topological space (Y, \mathcal{T}_1) such that with the induced topology \mathcal{T}_2 , the space (A, \mathcal{T}_2) is a Souslin space, then A is said to be an **analytic set** in (Y, \mathcal{T}_1) .

Obviously every Polish space is a Souslin space. Exercises 6.1#12 and #11 show that the converse is false as a Souslin space need not be metrizable. However, we shall see that even a metrizable Souslin space is not necessarily a Polish space. To see this we note that **every countable topological space is a Souslin space** as it is a continuous image of the discrete space \mathbb{N} ; one such space is the metrizable space \mathbb{Q} which we shall soon see is not a Polish space.

We know that two topological spaces are equivalent if they are homeomorphic. It is natural to ask when are two metric spaces equivalent (as metric spaces)? The relevant concept was introduced in Exercises 6.1#10, namely that of isometric.

6.3.20 Definition. Let (X, d) and (Y, d_1) be metric spaces. Then (X, d) is said to be **isometric** to (Y, d_1) if there exists a surjective mapping $f : X \rightarrow Y$ such that for all x_1 and x_2 in X , $d(x_1, x_2) = d_1(f(x_1), f(x_2))$. Such a mapping f is said to be an **isometry**.

Let d be any metric on \mathbb{R} and a any positive real number. If d_1 is defined to be $a \cdot d(x, y)$, for all $x, y \in \mathbb{R}$, then it is easily shown that (\mathbb{R}, d_1) is a metric space isometric to (\mathbb{R}, d) .

It is also easy to verify that any two isometric metric spaces have their associated topological spaces homeomorphic and every isometry is also a homeomorphism of the associated topological spaces.

6.3.21 Definition. Let (X, d) and (Y, d_1) be metric spaces and f a mapping of X into Y . Let $Z = f(X)$, and d_2 be the metric induced on Z by d_1 on Y . If $f : (X, d) \rightarrow (Z, d_2)$ is an isometry, then f is said to be an **isometric embedding** of (X, d) in (Y, d_1) .

Of course the natural embedding of \mathbb{Q} with the euclidean metric in \mathbb{R} with the euclidean metric is an isometric embedding. It is also the case that \mathbb{N} with the euclidean metric has a natural isometric embedding into both \mathbb{R} and \mathbb{Q} with the euclidean metric.

6.3.22 Definition. Let (X, d) and (Y, d_1) be metric spaces and f a mapping of X into Y . If (Y, d_1) is a complete metric space, $f : (X, d) \rightarrow (Y, d_1)$ is an isometric embedding and $f(X)$ is a dense subset of Y in the associated topological space, then (Y, d_1) is said to be a **completion** of (X, d) .

Clearly \mathbb{R} with the euclidean metric is a completion of \mathbb{Q} , the set of rationals with the euclidean metric, and of \mathbb{P} , the set of irrationals with the euclidean metric.

Two questions immediately jump to mind: (1) Does every metric space have a completion? (2) Is the completion of a metric space unique in some sense? We shall see that the answer to both questions is “yes”.

6.3.23 Proposition. Let (X, d) be any metric space. Then (X, d) has a completion.

Outline Proof. We begin by saying that two Cauchy sequences $\{y_n\}$ and $\{z_n\}$ in (X, d) are equivalent if $d(y_n, z_n) \rightarrow 0$ in \mathbb{R} . This is indeed an equivalence relation; that is, it is reflexive, symmetric and transitive. Now let \tilde{X} be the set of all equivalence classes of equivalent Cauchy sequences in (X, d) . We wish to put a metric on \tilde{X} .

Let \tilde{y} and \tilde{z} be any two points in \tilde{X} . Let Cauchy sequences $\{y_n\} \in \tilde{y}$ and $\{z_n\} \in \tilde{z}$. Now the sequence $\{d(y_n, z_n)\}$ is a Cauchy sequence in \mathbb{R} . (See Exercises 6.3#8.) As \mathbb{R} is a complete metric space, this Cauchy sequence in \mathbb{R} converges to some number, which we shall denote by $d_1(\tilde{y}, \tilde{z})$. It is straightforward to show that $d_1(\tilde{y}, \tilde{z})$ is not dependent on the choice of the sequence $\{y_n\}$ in \tilde{y} and $\{z_n\}$ in \tilde{z} .

For each $x \in X$, the constant sequence x, x, \dots, x, \dots is a Cauchy sequence in (X, d) converging to x . Let \tilde{x} denote the equivalence class of all Cauchy sequences converging to $x \in X$. Define the subset Y of \tilde{X} to be $\{\tilde{x} : x \in X\}$. If d_2 is the metric on Y induced by the metric d_1 on \tilde{X} , then it is clear that the mapping $f : (X, d) \rightarrow (Y, d_2)$, given by $f(x) = \tilde{x}$, is an isometry.

Now we show that Y is dense in \tilde{X} . To do this we show that for any given real number $\varepsilon > 0$, and $z \in \tilde{X}$, there is a $\tilde{x} \in Y$, such that $d_1(z, \tilde{x}) < \varepsilon$. Note that z is an equivalence class of Cauchy sequences. Let $\{x_n\}$ be a Cauchy sequence in this equivalence class z . There exists a positive integer n_0 , such that for all $n > n_0$, $d_1(x_n, x_{n_0}) < \varepsilon$. We now consider the constant sequence $x_{n_0}, x_{n_0}, \dots, x_{n_0}, \dots$. This lies in the equivalence class \tilde{x}_{n_0} , which is in Y . Further, $d(\tilde{x}_{n_0}, z) \leq \varepsilon$. So Y is indeed dense in \tilde{X} .

Finally, we show that (\tilde{X}, d_1) is a complete metric space. Let $\{z_n\}$ be a Cauchy sequence in this space. We are required to show that it converges. As Y is dense, for each positive integer n , there exists $\tilde{x}_n \in Y$, such that $d_1(\tilde{x}_n, z_n) < 1/n$. We show that $\{\tilde{x}_n\}$ is a Cauchy sequence in Y .

Consider a real number $\varepsilon > 0$. There exists a positive integer N , such that $d_1(z_n, z_m) < \varepsilon/2$ for $n, m > N$. Now take a positive integer n_1 , with $1/n_1 < \varepsilon/4$. For $n, m > n_1 + N$, we have

$$d_1(\tilde{x}_n, \tilde{x}_m) < d_1(\tilde{x}_n, z_n) + d_1(z_n, z_m) + d_1(z_m, \tilde{x}_m) < 1/n + \varepsilon/2 + 1/m < \varepsilon.$$

So $\{\tilde{x}_n\}$ is a Cauchy sequence in Y . This implies that $\{x_n\}$ is a Cauchy sequence in (X, d) . Hence $\{x_n\} \in z$, for some $z \in Z$. It is now straightforward to show first that $\tilde{x}_n \rightarrow z$ and then that $z_n \rightarrow z$, which completes the proof. \square

6.3.24 Proposition. Let (A, d_1) and (B, d_2) be complete metric spaces. Let X be a subset of (A, d_1) with induced metric d_3 , and Y a subset of (B, d_2) with induced metric d_4 . Further, let X be dense in (A, d_1) and Y dense in (B, d_2) . If there is an isometry $f : (X, d_3) \rightarrow (Y, d_4)$, then there exists an isometry $g : (A, d_1) \rightarrow (B, d_2)$, such that $g(x) = f(x)$, for all $x \in X$.

Outline Proof. Let $a \in A$. As X is dense in (A, d_1) , there exists a sequence $x_n \rightarrow a$, where each $x_n \in X$. So $\{x_n\}$ is a Cauchy sequence. As f is an isometry, $\{f(x_n)\}$ is a Cauchy sequence in (Y, d_4) and hence also a Cauchy sequence in (B, d_2) . Since (B, d_2) is a complete metric space, there exists a $b \in B$, such that $f(x_n) \rightarrow b$. So we define $g(a) = b$.

To show that g is a well-defined map of A into B , it is necessary to verify that if $\{z_n\}$ is any other sequence in X converging to a , then $f(z_n) \rightarrow b$. This follows from the fact that $d_1(x_n, z_n) \rightarrow 0$ and thus $d_2(f(x_n), f(z_n)) = d_4(f(x_n), f(z_n)) \rightarrow 0$.

Next we need to show that $g : A \rightarrow B$ is one-to-one and onto. This is left as an exercise as it is routine.

Finally, let $a_1, a_2 \in A$ and $x_{1n} \rightarrow a_1$ and $x_{2n} \rightarrow a_2$, where each a_{1n} and each a_{2n} is in X . Then

$$d_1(a_1, a_2) = \lim_{n \rightarrow \infty} d_3(a_{1n}, a_{2n}) = \lim_{n \rightarrow \infty} d_4(f(a_{1n}), f(a_{2n})) = d_2(g(a_1), g(a_2))$$

and so g is indeed an isometry, as required. \square

Proposition 6.3.24 says that, up to isometry, the completion of a metric spaces is unique.

We conclude this section with another concept. Recall that in Example 6.1.9 we introduced the concept of a normed vector space. We now define a very important class of normed vector spaces.

6.3.25 Definition. Let $(N, \| \cdot \|)$ be a normed vector space and d the associated metric on the set N . Then $(N, \| \cdot \|)$ is said to be a **Banach space** if (N, d) is a complete metric space.

From Proposition 6.3.23 we know that every normed vector space has a completion. However, the rather pleasant feature is that this completion is in fact also a normed vector space and so is a Banach space. (See Exercises 6.3#12.)

Exercises 6.3

1. Verify that the sequence $\{x_n = \sum_{i=0}^n \frac{1}{i!}\}$ is a Cauchy sequence in \mathbb{Q} with the euclidean metric. [This sequence does not converge in \mathbb{Q} . In \mathbb{R} it converges to the number e , which is known to be irrational. For a proof that e is irrational, indeed transcendental, see Jones et al. [112].]
2. Prove that every subsequence of a Cauchy sequence is a Cauchy sequence.
3. Give an example of a sequence in \mathbb{R} with the euclidean metric which has no subsequence which is a Cauchy sequence.
4. Using Corollary 6.3.11, prove that, for each positive integer m , the metric space \mathbb{R}^m with the euclidean metric is a complete metric space.

[Hint. Let $\{ \langle x_{1n}, x_{2n}, \dots, x_{mn} \rangle : n = 1, 2, \dots \}$ be a Cauchy sequence in \mathbb{R}^m . Prove that, for each $i = 1, 2, \dots, m$, the sequence $\{x_{in} : n = 1, 2, \dots\}$ in \mathbb{R} with the euclidean metric is a Cauchy sequence and so converges to a point a_i . Then show that the sequence $\{ \langle x_{1n}, x_{2n}, \dots, x_{mn} \rangle : n = 1, 2, \dots \}$ converges to the point $\langle a_1, a_2, \dots, a_m \rangle$.]

5. Prove that every closed subspace of a complete metric space is complete and that every complete metric subspace of a metric space is closed.
6. Prove that for each positive integer n , \mathbb{R}^n is a Polish space.
7. Let $a, b \in \mathbb{R}$, with $a < b$. Prove that each discrete space and each of the spaces $[a, b]$, (a, b) , $[a, b)$, $(a, b]$, $(-\infty, a)$, $(-\infty, a]$, (a, ∞) , $[a, \infty)$, and $\{a\}$, with its induced topology is a Polish Spaces.
8. If (X, d) is a metric space and $\{x_n\}$ and $\{y_n\}$ are Cauchy sequences, prove that $\{d(x_n, y_n)\}$ is a Cauchy sequence in \mathbb{R} .
9. Fill in the missing details in the proof of Proposition 6.3.23.
10. Fill in the missing details in the proof of Proposition 6.3.24.

- 11*. Show that each of the spaces (ℓ_1, d_1) , (ℓ_2, d_2) , (c_0, d_0) , and (ℓ_∞, d_∞) of Exercises 6.1#7 is a complete metric space. Indeed, show that each of these spaces is a Banach space in a natural way.
- 12*. Let X be any normed vector space. Prove that it is possible to put a normed vector space structure on \tilde{X} , the complete metric space constructed in Proposition 6.3.23. So every normed vector space has a completion which is a Banach space.

6.4 Contraction Mappings

In Chapter 5 we had our first glimpse of a fixed point theorem. In this section we shall meet another type of fixed point theorem. This section is very much part of metric space theory rather than general topology. Nevertheless the topic is important for applications.

6.4.1 Definition. Let f be a mapping of a set X into itself. Then a point $x \in X$ is said to be a **fixed point** of f if $f(x) = x$.

6.4.2 Definition. Let (X, d) be a metric space and f a mapping of X into itself. Then f is said to be a **contraction mapping** if there exists an $r \in (0, 1)$, such that

$$d(f(x_1), f(x_2)) \leq r \cdot d(x_1, x_2), \quad \text{for all } x_1, x_2 \in X.$$

6.4.3 Proposition. Let f be a contraction mapping of the metric space (X, d) . Then f is a continuous mapping.

Proof. See Exercises 6.4#1. □

6.4.4 Theorem. (Contraction Mapping Theorem or Banach Fixed Point Theorem) Let (X, d) be a complete metric space and f a contraction mapping of (X, d) into itself. Then f has precisely one fixed point.

Proof. Let x be any point in X and consider the sequence

$$x, f(x), f^2(x) = f(f(x)), f^3(x) = f(f(f(x))), \dots, f^n(x), \dots$$

We shall show this is a Cauchy sequence. Put $a = d(x, f(x))$. As f is a contraction mapping, there exists $r \in (0, 1)$, such that $d(f(x_1), f(x_2)) \leq r \cdot d(x_1, x_2)$, for all $x_1, x_2 \in X$.

Let m and n be any positive integers, with $n > m$. Then

$$\begin{aligned} d(f^m(x), f^n(x)) &= d(f^m(x), f^m(f^{n-m}(x))) \\ &\leq r^m \cdot d(x, f^{n-m}(x)) \\ &\leq r^m \cdot (d(x, f(x)) + d(f(x), f^2(x)) + \dots + d(f^{n-m-1}(x), f^{n-m}(x))) \\ &\leq r^m \cdot d(x, f(x)) [1 + r + r^2 + \dots + r^{n-m-1}] \\ &\leq \frac{r^m \cdot a}{1 - r} \end{aligned}$$

As $r < 1$, it is clear that $\{f^n(x)\}$ is a Cauchy sequence. As (X, d) is complete there is a $z \in X$, such that $f^n(x) \rightarrow z$.

By Proposition 6.4.3, f is continuous and so

$$f(z) = f\left(\lim_{n \rightarrow \infty} f^n(x)\right) = \lim_{n \rightarrow \infty} f^{n+1}(x) = z \quad (6.1)$$

and so z is indeed a fixed point of f .

Finally, let t be any fixed point of f . Then

$$d(t, z) = d(f(t), f(z)) \leq r \cdot d(t, z). \quad (6.2)$$

As $r < 1$, this implies $d(t, z) = 0$ and thus $t = z$ and f has only one fixed point. \square

It is worth mentioning that the Contraction Mapping Theorem provides not only an existence proof of a fixed point but also a construction for finding it; namely, let x be any point in X and find the limit of the sequence $\{f^n(x)\}$. This method allows us to write a computer program to approximate the limit point to any desired accuracy.

Exercises 6.4

1. Prove Proposition 6.4.3.
2. Extend the Contraction Mapping Theorem by showing that if f is a mapping of a complete metric space (X, d) into itself and f^N is a contraction mapping for some positive integer N , then f has precisely one fixed point.
3. The Mean Value Theorem says: Let f be a real-valued function on a closed unit interval $[a, b]$ which is continuous on $[a, b]$ and differentiable on (a, b) . Then there exists a point $c \in [a, b]$ such that $f(b) - f(a) = f'(c)(b - a)$. (Recall that f is said to be **differentiable** at a point s if $\lim_{x \rightarrow s} \frac{f(x) - f(s)}{x - s} = f'(s)$ exists.)

Using the Mean Value Theorem prove the following:

Let $f : [a, b] \rightarrow [a, b]$ be differentiable. Then f is a contraction if and only if there exists $r \in (0, 1)$ such that $|f'(x)| \leq r$, for all $x \in [a, b]$.

4. Using Exercises 3 and 2 above, show that while $f : \mathbb{R} \rightarrow \mathbb{R}$ given by $f(x) = \cos x$ does not satisfy the conditions of the Contraction Mapping Theorem, it nevertheless has a unique fixed point.

6.5 Baire Spaces

6.5.1 Theorem. (Baire Category Theorem) Let (X, d) be a complete metric space. If $X_1, X_2, \dots, X_n, \dots$ is a sequence of open dense subsets of X , then the set $\bigcap_{n=1}^{\infty} X_n$ is also dense in X .

Proof. It suffices to show that if U is any open subset of (X, d) , then $U \cap \bigcap_{n=1}^{\infty} X_n \neq \emptyset$.

As X_1 is open and dense in X , the set $U \cap X_1$ is a non-empty open subset of (X, d) . Let U_1 be an open ball of radius at most 1, such that $\overline{U_1} \subset U \cap X_1$.

Inductively define for each positive integer $n > 1$, an open ball U_n of radius at most $1/n$ such that $\overline{U_n} \subset U_{n-1} \cap X_n$.

For each positive integer n , let x_n be any point in U_n . Clearly the sequence $\{x_n\}$ is a Cauchy sequence. As (X, d) is a complete metric space, this sequence converges to a point $x \in X$.

Observe that for every positive integer m , every member of the sequence $\{x_n\}$ is in the closed set $\overline{U_m}$, and so the limit point x is also in the set $\overline{U_m}$.

Then $x \in \overline{U_n}$, for all $n \in \mathbb{N}$. Thus $x \in \bigcap_{n=1}^{\infty} \overline{U_n}$.

But as $U \cap \bigcap_{n=1}^{\infty} X_n \supset \bigcap_{n=1}^{\infty} \overline{U_n} \ni x$, this implies that $U \cap \bigcap_{n=1}^{\infty} X_n \neq \emptyset$, which completes the proof of the theorem. \square

In Exercises 3.2 #5 we introduced the notion of interior of a subset of a topological space.

6.5.2 Definition. Let (X, \mathcal{T}) be any topological space and A any subset of X . The largest open set contained in A is called the **interior** of A and is denoted by $\text{Int}(A)$.

6.5.3 Definition. A subset A of a topological space (X, \mathcal{T}) is said to be **nowhere dense** if the set \overline{A} has empty interior.

These definitions allow us to rephrase Theorem 6.5.1.

6.5.4 Corollary. Let (X, d) be a complete metric space. If $X_1, X_2, \dots, X_n, \dots$ is a sequence of subsets of X such that $X = \bigcup_{n=1}^{\infty} X_n$, then for at least one $n \in \mathbb{N}$, the set $\overline{X_n}$ has non-empty interior; that is, X_n is not nowhere dense.

Proof. Exercises 6.5 #2. □

6.5.5 Definition. A topological space (X, d) is said to be a **Baire space** if for every sequence $\{X_n\}$ of open dense subsets of X , the set $\bigcap_{n=1}^{\infty} X_n$ is also dense in X .

6.5.6 Corollary. Every complete metrizable space is a Baire space. □

6.5.7 Remarks. It is important to note that Corollary 6.5.6 is a result in topology, rather than a result in metric space theory.

Note also that there are Baire spaces which are not completely metrizable. (See Exercises 6.5 #4(iv).) □

6.5.8 Example. The topological space \mathbb{Q} is not a Baire space and so is not completely metrizable. To see this, note that the set of rational numbers is countable and let $\mathbb{Q} = \{x_1, x_2, \dots, x_n, \dots\}$. Each of the sets $X_n = \mathbb{Q} \setminus \{x_n\}$ is open and dense in \mathbb{Q} , however $\bigcap_{n=1}^{\infty} X_n = \emptyset$. Thus \mathbb{Q} does not have the Baire space property. □

6.5.9 Remark. You should note that (once we had the Baire Category Theorem) it was harder to prove that \mathbb{Q} is not completely metrizable than the more general result that \mathbb{Q} is not a Baire space. □

6.5.10 Definitions. Let Y be a subset of a topological space (X, \mathcal{T}) . If Y is a union of a countable number of nowhere dense subsets of X , then Y is said to be a set of the **first category** or **meager**. If Y is not first category, it is said to be a set of the **second category**.

The Baire Category Theorem has many applications in analysis, but these lie outside our study of Topology. However, we shall conclude this section with an important theorem in Banach space theory, namely the Open Mapping Theorem. This theorem is a consequence of the Baire Category Theorem.

6.5.11 Definition. Let S be a subset of a real vector space V . The set S is said to be **convex** if for each $x, y \in S$ and every real number $0 < \lambda < 1$, the point $\lambda x + (1 - \lambda)y$ is in S .

Clearly every subspace of a vector space is convex. Also in any normed vector space, every open ball and every closed ball is convex.

6.5.12 Theorem. (Open Mapping Theorem) Let $(B, \| \cdot \|)$ and $((B_1, \| \cdot \|_1))$ be Banach spaces and $L : B \rightarrow B_1$ a continuous linear (in the vector space sense) mapping of B onto B_1 . Then L is an open mapping.

Proof. By Exercises 6.5#1(iv), it suffices to show that there exists an $N \in \mathbb{N}$ such that $L(B_N(0)) \supset B_s(0)$, for some $s > 0$.

Clearly $B = \bigcup_{n=1}^{\infty} B_n(0)$ and as L is surjective we have $B_1 = L(B) = \bigcup_{n=1}^{\infty} L(B_n(0))$.

As B_1 is a Banach space, by Corollary 6.5.4 of the Baire Category Theorem, there is an $N \in \mathbb{N}$, such that $\overline{L(B_N(0))}$ has non-empty interior.

So there is a $z \in B_1$ and $t > 0$, such that $B_t(z) \subseteq \overline{L(B_N(0))}$.

By Exercises 6.5#3 there is no loss of generality in assuming that $z \in L(B_N(0))$.

But $B_t(z) = B_t(0) + z$, and so

$$B_t(0) \subseteq \overline{L(B_N(0))} - z = \overline{L(B_N(0)) - z} \subseteq \overline{L(B_N(0)) - L(B_N(0))} \subseteq \overline{L(B_{2N}(0))}.$$

which, by the linearity of L , implies that $B_{t/2}(0) \subseteq \overline{L(B_N(0))}$.

We shall show that this implies that $B_{t/4}(0) \subseteq L(B_N(0))$.

Let $w \in B_{t/2}(0)$. Then there is an $x_1 \in B_N(0)$, such that $\|w - L(x_1)\|_1 < \frac{t}{4}$.

Note that by linearity of the mapping L , for each integer $k > 0$

$$B_{t/2}(0) \subseteq \overline{L(B_N(0))} \implies B_{t/(2k)}(0) \subseteq \overline{L(B_{N/k}(0))}.$$

So there is an $x_2 \in B_{N/2}(0)$, such that

$$\|(w - L(x_1)) - L(x_2)\|_1 = \|w - L(x_1) - L(x_2)\|_1 < \frac{t}{8}.$$

Continuing in this way, we obtain by induction a sequence $\{x_m\}$ such that $\|x_m\| < \frac{N}{2^{m-1}}$ and

$$\|w - L(x_1 + x_2 + \cdots + x_m)\|_1 = \|w - L(x_1) - L(x_2) - \cdots - L(x_m)\|_1 < \frac{t}{2^m}.$$

Since B is complete, the series $\sum_{m=1}^{\infty} x_m$ converges to a limit a .

Clearly $\|a\| < 2N$ and by continuity of L , we have $w = L(a) \in L(B_{2N}(0))$.

So $B_{t/2}(0) \subseteq L(B_{2N}(0))$ and thus $B_{t/4}(0) \subseteq L(B_N(0))$ which completes the proof. \square

The following Corollary of the Open Mapping Theorem follows immediately and is a very important special case.

6.5.13 Corollary. A one-to-one continuous linear map of one Banach space onto another Banach space is a homeomorphism. In particular, a one-to-one continuous linear map of a Banach space onto itself is a homeomorphism. □

Exercises 6.5

1. Let (X, \mathcal{T}) and (Y, \mathcal{T}_1) be topological spaces. A mapping $f : (X, \mathcal{T}) \rightarrow (Y, \mathcal{T}_1)$ is said to be an **open mapping** if for every open subset A of (X, \mathcal{T}) , the set $f(A)$ is open in (Y, \mathcal{T}_1) .
 - (i) Show that f is an open mapping if and only if for each $U \in \tau$ and each $x \in U$, the set $f(U)$ is a neighbourhood of $f(x)$.
 - (ii) Let (X, d) and (Y, d_1) be metric spaces and f a mapping of X into Y . Prove that f is an open mapping if and only if for each $n \in \mathbb{N}$ and each $x \in X$, $f(B_{1/n}(x)) \supseteq B_r(f(x))$, for some $r > 0$.
 - (iii) Let $(N, \| \cdot \|)$ and $(N_1, \| \cdot \|_1)$ be normed vector spaces and f a linear mapping of N into N_1 . Prove that f is an open mapping if and only if for each $n \in \mathbb{N}$, $f(B_{1/n}(0)) \supseteq B_r(0)$, for some $r > 0$.
 - (iv) Let $(N, \| \cdot \|)$ and $(N_1, \| \cdot \|_1)$ be normed vector spaces and f a linear mapping of N into N_1 . Prove that f is an open mapping if and only if there exists an $s > 0$ such that $f(B_s(0)) \supseteq B_r(0)$, for some $r > 0$.

2. Using the Baire Category Theorem, prove Corollary 6.5.4.

3. Let A be a subset of a Banach space B . Prove the following are equivalent:
- (i) the set \overline{A} has non-empty interior;
 - (ii) there exists a $z \in \overline{A}$ and $t > 0$ such that $B_t(z) \subseteq \overline{A}$;
 - (ii) there exists a $y \in A$ and $r > 0$ such that $B_r(y) \subseteq \overline{A}$.
4. A point x in a topological space (X, \mathcal{T}) is said to be an **isolated point** if $\{x\} \in \mathcal{T}$. Prove that if (X, \mathcal{T}) is a countable T_1 -space with no isolated points, then it is not a Baire space.
5. Using the version of the Baire Category Theorem in Corollary 6.5.4, prove that \mathbb{P} is not an F_σ -set and \mathbb{Q} is not a G_δ -set in \mathbb{R} .
 [Hint. Suppose that $\mathbb{P} = \bigcup_{n=1}^{\infty} F_n$, where each F_n is a closed subset of \mathbb{R} . Then apply Corollary 6.5.4 to $\mathbb{R} = \bigcup_{n=1}^{\infty} F_n \cup \bigcup_{q \in \mathbb{Q}} \{q\}$.]
6. (i) Let (X, \mathcal{T}) be any topological space, and Y and S dense subsets of X . If S is also open in (X, \mathcal{T}) , prove that $S \cap Y$ is dense in both X and Y .
- (ii) Let \mathcal{T}_1 be the topology induced on Y by \mathcal{T} on X . Let $\{X_n\}$ be a sequence of open dense subsets of Y . Using (i), show that $\{X_n \cap Y\}$ is a sequence of open dense subsets of (Y, \mathcal{T}_1) .
- (iii) Deduce from Definition 6.5.5 and (ii) above, that if (Y, \mathcal{T}_1) is a Baire space, then (X, \mathcal{T}) is also a Baire space. [So [the closure of a Baire space is a Baire space](#).]
- (iv) Using (iii), show that the subspace (Z, \mathcal{T}_2) of \mathbb{R}^2 given by

$$Z = \{\langle x, y \rangle : x, y \in \mathbb{R}, y > 0\} \cup \{\langle x, 0 \rangle : x \in \mathbb{Q}\},$$

is a Baire space, but is not completely metrizable as the closed subspace $\{\langle x, 0 \rangle : x \in \mathbb{Q}\}$ is homeomorphic to \mathbb{Q} which is not completely metrizable.

7. Let (X, \mathcal{T}) and (Y, \mathcal{T}_1) be topological spaces and $f : (X, \mathcal{T}) \rightarrow (Y, \mathcal{T}_1)$ be a continuous open mapping. If (X, \mathcal{T}) is a Baire space, prove that (Y, \mathcal{T}_1) is a Baire space. [So [an open continuous image of a Baire space is a Baire space](#).]
8. Let (Y, \mathcal{T}_1) be an open subspace of the Baire space (X, \mathcal{T}) . Prove that (Y, \mathcal{T}) is a Baire space. [So [an open subspace of a Baire space is a Baire space](#).]

9. Let (X, \mathcal{T}) be a topological space. A function $f : (X, \mathcal{T}) \rightarrow \mathbb{R}$ is said to be **lower semicontinuous** if for each $r \in \mathbb{R}$, the set $f^{-1}((-\infty, r])$ is closed in (X, \mathcal{T}) . A function $f : (X, \mathcal{T}) \rightarrow \mathbb{R}$ is said to be **upper semicontinuous** if for each $r \in \mathbb{R}$, the set $f^{-1}((-\infty, r))$ is open in (X, \mathcal{T}) .

(i) Prove that f is continuous if and only if it is lower semicontinuous and upper semicontinuous.

(ii) Let (X, \mathcal{T}) be a Baire space, I an index set and for each $x \in X$, let the set $\{f_i(x) : i \in I\}$ be bounded above, where each mapping $f_i : (X, \mathcal{T}) \rightarrow \mathbb{R}$ is lower semicontinuous. Using the Baire Category Theorem prove that there exists an open subset O of (X, \mathcal{T}) such that the set $\{f_i(x) : x \in O, i \in I\}$ is bounded above.

[Hint. Let $X_n = \bigcap_{i \in I} f_i^{-1}((-\infty, n])$.]

10. Let B be a Banach space where the dimension of the underlying vector space is countable. Using the Baire Category Theorem, prove that the dimension of the underlying vector space is, in fact, finite.

11. Let $(N, \| \cdot \|)$ be a normed vector space and (X, τ) a convex subset of $(N, \| \cdot \|)$ with its induced topology. Show that (X, τ) is path-connected, and hence also connected. Deduce that every open ball in $(N, \| \cdot \|)$ is path-connected as is $(N, \| \cdot \|)$ itself.

6.6 Postscript

Metric space theory is an important topic in its own right. As well, metric spaces hold an important position in the study of topology. Indeed many books on topology begin with metric spaces, and motivate the study of topology via them.

We saw that different metrics on the same set can give rise to the same topology. Such metrics are called equivalent metrics. We were introduced to the study of function spaces, and in particular, $C[0, 1]$. En route we met normed vector spaces, a central topic in functional analysis.

Not all topological spaces arise from metric spaces. We saw this by observing that topologies induced by metrics are Hausdorff.

We saw that the topology of a metric space can be described entirely in terms of its convergent sequences and that continuous functions between metric spaces can also be so described.

Exercises 6.2 #9 introduced the interesting concept of distance between sets in a metric space.

We met the concepts of Cauchy sequence, complete metric space, completely metrizable space, Banach space, Polish space, and Souslin space. Completeness is an important topic in metric space theory because of the central role it plays in applications in analysis. Banach spaces are complete normed vector spaces and are used in many contexts in analysis and have a rich structure theory. We saw that every metric space has a completion, that is can be embedded isometrically in a complete metric space. For example every normed vector space has a completion which is a Banach space.

Contraction mappings were introduced in the concept of fixed points and we saw the proof of the Contraction Mapping Theorem which is also known as the Banach Fixed Point Theorem. This is a very useful theorem in applications for example in the proof of existence of solutions of differential equations.

Another powerful theorem proved in this chapter was the Baire Category Theorem. We introduced the topological notion of a Baire space and saw that every completely metrizable space is a Baire space. En route the notion of first category or meager was introduced. And then we proved the Open Mapping Theorem which says that a continuous linear map from a Banach space onto another Banach space must be an open mapping.

This Chapter is not yet complete. Material that is yet to be included (1) Hausdorff dimension (2) uniform continuity and the Postscript is to be revised

Chapter 7

Compactness

Introduction

The most important topological property is compactness. It plays a key role in many branches of mathematics. It would be fair to say that until you understand compactness you do not understand topology!

So what is compactness? It could be described as the topologists generalization of finiteness. The formal definition says that a topological space is compact if whenever it is a subset of a union of an infinite number of open sets then it is also a subset of a union of a finite number of these open sets. Obviously every finite subset of a topological space is compact. And we quickly see that in a discrete space a set is compact if and only if it is finite. When we move to topological spaces with richer topological structures, such as \mathbb{R} , we discover that infinite sets can be compact. Indeed all closed intervals $[a, b]$ in \mathbb{R} are compact. But intervals of this type are the only ones which are compact.

So we are led to ask: precisely which subsets of \mathbb{R} are compact? The Heine-Borel Theorem will tell us that the compact subsets of \mathbb{R} are precisely the sets which are both closed and bounded.

As we go farther into our study of topology, we shall see that compactness plays a crucial role. This is especially so of applications of topology to analysis.

7.1 Compact Spaces

7.1.1 Definition. Let A be a subset of a topological space (X, \mathcal{T}) . Then A is said to be **compact** if for every set I and every family of open sets, O_i , $i \in I$, such that $A \subseteq \bigcup_{i \in I} O_i$ there exists a finite subfamily $O_{i_1}, O_{i_2}, \dots, O_{i_n}$ such that $A \subseteq O_{i_1} \cup O_{i_2} \cup \dots \cup O_{i_n}$.

7.1.2 Example. If $(X, \mathcal{T}) = \mathbb{R}$ and $A = (0, \infty)$, then A is not compact.

Proof. For each positive integer i , let O_i be the open interval $(0, i)$. Then, clearly, $A \subseteq \bigcup_{i=1}^{\infty} O_i$. But there do *not* exist i_1, i_2, \dots, i_n such that $A \subseteq (0, i_1) \cup (0, i_2) \cup \dots \cup (0, i_n)$. Therefore A is not compact. \square

7.1.3 Example. Let (X, \mathcal{T}) be any topological space and $A = \{x_1, x_2, \dots, x_n\}$ any finite subset of (X, \mathcal{T}) . Then A is compact.

Proof. Let O_i , $i \in I$, be any family of open sets such that $A \subseteq \bigcup_{i \in I} O_i$. Then for each $x_j \in A$, there exists an O_{i_j} , such that $x_j \in O_{i_j}$. Thus $A \subseteq O_{i_1} \cup O_{i_2} \cup \dots \cup O_{i_n}$. So A is compact. \square

7.1.4 Remark. So we see from Example 7.1.3 that every finite set (in a topological space) is compact. Indeed “compactness” can be thought of as a topological generalization of “finiteness”. \square

7.1.5 Example. A subset A of a discrete space (X, \mathcal{T}) is compact if and only if it is finite.

Proof. If A is finite then Example 7.1.3 shows that it is compact.

Conversely, let A be compact. Then the family of singleton sets $O_x = \{x\}$, $x \in A$ is such that each O_x is open and $A \subseteq \bigcup_{x \in A} O_x$. As A is compact, there exist $O_{x_1}, O_{x_2}, \dots, O_{x_n}$ such that $A \subseteq O_{x_1} \cup O_{x_2} \cup \dots \cup O_{x_n}$; that is, $A \subseteq \{x_1, \dots, x_n\}$. Hence A is a finite set. \square

Of course if all compact sets were finite then the study of “compactness” would not be interesting. However we shall see shortly that, for example, every closed interval $[a, b]$ is compact. Firstly, we introduce a little terminology.

7.1.6 Definitions. Let I be a set and $O_i, i \in I$, a family of open sets in a topological space (X, \mathcal{T}) . Let A be a subset of (X, \mathcal{T}) . Then $O_i, i \in I$, is said to be an **open covering** of A if $A \subseteq \bigcup_{i \in I} O_i$. A finite subfamily, $O_{i_1}, O_{i_2}, \dots, O_{i_n}$, of $O_i, i \in I$ is called a **finite subcovering** (of A) if $A \subseteq O_{i_1} \cup O_{i_2} \cup \dots \cup O_{i_n}$.

So we can rephrase the definition of compactness as follows:

7.1.7 Definitions. A subset A of a topological space (X, \mathcal{T}) is said to be **compact** if every open covering of A has a finite subcovering. If the compact subset A equals X , then (X, \mathcal{T}) is said to be a **compact space**.

7.1.8 Remark. We leave as an exercise the verification of the following statement:

Let A be a subset of (X, \mathcal{T}) and \mathcal{T}_1 the topology induced on A by \mathcal{T} . Then A is a compact subset of (X, \mathcal{T}) if and only if (A, \mathcal{T}_1) is a compact space.

[This statement is not as trivial as it may appear at first sight.] □

7.1.9 Proposition. The closed interval $[0, 1]$ is compact.

Proof. Let $O_i, i \in I$ be any open covering of $[0, 1]$. Then for each $x \in [0, 1]$, there is an O_i such that $x \in O_i$. As O_i is open about x , there exists an interval U_x , open in $[0, 1]$ such that $x \in U_x \subseteq O_i$.

Now define a subset S of $[0, 1]$ as follows:

$$S = \{z : [0, z] \text{ can be covered by a finite number of the sets } U_x\}.$$

[So $z \in S \Rightarrow [0, z] \subseteq U_{x_1} \cup U_{x_2} \cup \dots \cup U_{x_n}$, for some x_1, x_2, \dots, x_n .]

Now let $x \in S$ and $y \in U_x$. Then as U_x is an interval containing x and y , $[x, y] \subseteq U_x$. (Here we are assuming, without loss of generality that $x \leq y$.) So

$$[0, y] \subseteq U_{x_1} \cup U_{x_2} \cup \dots \cup U_{x_n} \cup U_x$$

and hence $y \in S$.

So for each $x \in [0, 1]$, $U_x \cap S = U_x$ or \emptyset .

This implies that

$$S = \bigcup_{x \in S} U_x$$

and

$$[0, 1] \setminus S = \bigcup_{x \notin S} U_x.$$

Thus we have that S is open in $[0, 1]$ and S is closed in $[0, 1]$. But $[0, 1]$ is connected. Therefore $S = [0, 1]$ or \emptyset .

However $0 \in S$ and so $S = [0, 1]$; that is, $[0, 1]$ can be covered by a finite number of U_x . So $[0, 1] \subseteq U_{x_1} \cup U_{x_2} \cup \dots \cup U_{x_m}$. But each U_{x_i} is contained in an $O_i, i \in I$. Hence $[0, 1] \subseteq O_{i_1} \cup O_{i_2} \cup \dots \cup O_{i_m}$ and we have shown that $[0, 1]$ is compact. \square

Exercises 7.1

1. Let (X, \mathcal{T}) be an indiscrete space. Prove that every subset of X is compact.
2. Let \mathcal{T} be the finite-closed topology on any set X . Prove that every subset of (X, \mathcal{T}) is compact.
3. Prove that each of the following spaces is *not* compact.
 - (i) $(0, 1)$;
 - (ii) $[0, 1)$;
 - (iii) \mathbb{Q} ;
 - (iv) \mathbb{P} ;
 - (v) \mathbb{R}^2 ;
 - (vi) the open disc $D = \{(x, y) : x^2 + y^2 < 1\}$ considered as a subspace of \mathbb{R}^2 ;
 - (vii) the Sorgenfrey line;
 - (viii) $C[0, 1]$ with the topology induced by the metric d of Example 6.1.5;
 - (ix) $\ell_1, \ell_2, \ell_\infty, c_0$ with the topologies induced respectively by the metrics d_1, d_2, d_∞ , and d_0 of Exercises 6.1 #7.
4. Is $[0, 1]$ a compact subset of the Sorgenfrey line?
5. Is $[0, 1] \cap \mathbb{Q}$ a compact subset of \mathbb{Q} ?
6. Verify that $S = \{0\} \cup \bigcup_{n=1}^{\infty} \{\frac{1}{n}\}$ is a compact subset of \mathbb{R} while $\bigcup_{n=1}^{\infty} \{\frac{1}{n}\}$ is not.

7.2 The Heine-Borel Theorem

The next proposition says that “a continuous image of a compact space is compact”.

7.2.1 Proposition. Let $f : (X, \mathcal{T}) \rightarrow (Y, \mathcal{T}_1)$ be a continuous surjective map. If (X, \mathcal{T}) is compact, then (Y, \mathcal{T}_1) is compact.

Proof. Let $O_i, i \in I$, be any open covering of Y ; that is $Y \subseteq \bigcup_{i \in I} O_i$.

Then $f^{-1}(Y) \subseteq f^{-1}(\bigcup_{i \in I} O_i)$; that is, $X \subseteq \bigcup_{i \in I} f^{-1}(O_i)$.

So $f^{-1}(O_i), i \in I$, is an open covering of X .

As X is compact, there exist i_1, i_2, \dots, i_n in I such that

$$X \subseteq f^{-1}(O_{i_1}) \cup f^{-1}(O_{i_2}) \cup \dots \cup f^{-1}(O_{i_n}).$$

$$\text{So } Y = f(X)$$

$$\subseteq f(f^{-1}(O_{i_1}) \cup f^{-1}(O_{i_2}) \cup \dots \cup f^{-1}(O_{i_n}))$$

$$= f(f^{-1}(O_{i_1})) \cup f(f^{-1}(O_{i_2})) \cup \dots \cup f(f^{-1}(O_{i_n}))$$

$$= O_{i_1} \cup O_{i_2} \cup \dots \cup O_{i_n}, \quad \text{since } f \text{ is surjective.}$$

So we have $Y \subseteq O_{i_1} \cup O_{i_2} \cup \dots \cup O_{i_n}$; that is, Y is covered by a finite number of O_i .

Hence Y is compact. □

7.2.2 Corollary. Let (X, \mathcal{T}) and (Y, \mathcal{T}_1) be homeomorphic topological spaces. If (X, \mathcal{T}) is compact, then (Y, \mathcal{T}_1) is compact. □

7.2.3 Corollary. For a and b in \mathbb{R} with $a < b$, $[a, b]$ is compact while (a, b) is not compact.

Proof. The space $[a, b]$ is homeomorphic to the compact space $[0, 1]$ and so, by Proposition 7.2.1, is compact.

The space (a, b) is homeomorphic to $(0, \infty)$. If (a, b) were compact, then $(0, \infty)$ would be compact, but we saw in Example 7.1.2 that $(0, \infty)$ is not compact. Hence (a, b) is not compact. □

7.2.4 Proposition. Every closed subset of a compact space is compact.

Proof. Let A be a closed subset of a compact space (X, \mathcal{T}) . Let $U_i \in \mathcal{T}$, $i \in I$, be any open covering of A . Then

$$X \subseteq \left(\bigcup_{i \in I} U_i \right) \cup (X \setminus A);$$

that is, U_i , $i \in I$, together with the open set $X \setminus A$ is an open covering of X . Therefore there exists a finite subcovering $U_{i_1}, U_{i_2}, \dots, U_{i_k}, X \setminus A$. [If $X \setminus A$ is not in the finite subcovering then we can include it and still have a finite subcovering of X .]

So

$$X \subseteq U_{i_1} \cup U_{i_2} \cup \dots \cup U_{i_k} \cup (X \setminus A).$$

Therefore,

$$A \subseteq U_{i_1} \cup U_{i_2} \cup \dots \cup U_{i_k} \cup (X \setminus A)$$

which clearly implies

$$A \subseteq U_{i_1} \cup U_{i_2} \cup \dots \cup U_{i_k}$$

since $A \cap (X \setminus A) = \emptyset$. Hence A has a finite subcovering and so is compact. \square

7.2.5 Proposition. A compact subset of a Hausdorff topological space is closed.

Proof. Let A be a compact subset of the Hausdorff space (X, \mathcal{T}) . We shall show that A contains all its limit points and hence is closed. Let $p \in X \setminus A$. Then for each $a \in A$, there exist open sets U_a and V_a such that $a \in U_a$, $p \in V_a$ and $U_a \cap V_a = \emptyset$.

Then $A \subseteq \bigcup_{a \in A} U_a$. As A is compact, there exist a_1, a_2, \dots, a_n in A such that

$$A \subseteq U_{a_1} \cup U_{a_2} \cup \dots \cup U_{a_n}.$$

Put $U = U_{a_1} \cup U_{a_2} \cup \dots \cup U_{a_n}$ and $V = V_{a_1} \cap V_{a_2} \cap \dots \cap V_{a_n}$. Then $p \in V$ and $V \cap U_a = \emptyset$ implies $V \cap U = \emptyset$ which in turn implies $V \cap A = \emptyset$. So p is not a limit point of A , and V is an open set containing p which does not intersect A .

Hence A contains all of its limit points and is therefore closed. \square

7.2.6 Corollary. A compact subset of a metrizable space is closed. \square

7.2.7 Example. For a and b in \mathbb{R} with $a < b$, the intervals $[a, b)$ and $(a, b]$ are not compact as they are not closed subsets of the metrizable space \mathbb{R} . \square

7.2.8 Proposition. A compact subset of \mathbb{R} is bounded.

Proof. Let $A \subseteq \mathbb{R}$ be unbounded. Then $A \subseteq \bigcup_{n=1}^{\infty} (-n, n)$, but $\{(-n, n) : n = 1, 2, 3, \dots\}$ does not have any finite subcovering of A as A is unbounded. Therefore A is not compact. Hence all compact subsets of \mathbb{R} are bounded. \square

7.2.9 Theorem. (Heine-Borel Theorem) Every closed bounded subset of \mathbb{R} is compact.

Proof. If A is a closed bounded subset of \mathbb{R} , then $A \subseteq [a, b]$, for some a and b in \mathbb{R} . As $[a, b]$ is compact and A is a closed subset, A is compact. \square

The Heine-Borel Theorem is an important result. The proof above is short only because we extracted and proved Proposition 7.1.9 first.

7.2.10 Proposition. (Converse of Heine-Borel Theorem) Every compact subset of \mathbb{R} is closed and bounded.

Proof. This follows immediately from Propositions 7.2.8 and 7.2.5. \square

7.2.11 Definition. A subset A of a metric space (X, d) is said to be **bounded** if there exists a real number r such that $d(a_1, a_2) \leq r$, for all a_1 and a_2 in A .

7.2.12 Proposition. Let A be a compact subset of a metric space (X, d) . Then A is closed and bounded.

Proof. By Corollary 7.2.6, A is a closed set. Now fix $x_0 \in X$ and define the mapping $f : (A, \mathcal{T}) \rightarrow \mathbb{R}$ by

$$f(a) = d(a, x_0), \text{ for every } a \in A,$$

where \mathcal{T} is the induced topology on A . Then f is continuous and so, by Proposition 7.2.1, $f(A)$ is compact. Thus, by Proposition 7.2.10, $f(A)$ is bounded; that is, there exists a real number M such that

$$f(a) \leq M, \text{ for all } a \in A.$$

Thus $d(a, x_0) \leq M$, for all $a \in A$. Putting $r = 2M$, we see by the triangle inequality that $d(a_1, a_2) \leq r$, for all a_1 and a_2 in A . \square

Recalling that \mathbb{R}^n denotes the n -dimensional euclidean space with the topology induced by the euclidean metric, it is possible to generalize the Heine-Borel Theorem and its converse from \mathbb{R} to \mathbb{R}^n , $n > 1$. We state the result here but delay its proof until the next chapter.

7.2.13 Theorem. (Generalized Heine-Borel Theorem) A subset of \mathbb{R}^n , $n \geq 1$, is compact if and only if it is closed and bounded.

Warning. Although Theorem 7.2.13 says that every closed bounded subset of \mathbb{R}^n is compact, closed bounded subsets of other metric spaces need not be compact. (See Exercises 7.2 #9.)

7.2.14 Proposition. Let (X, \mathcal{T}) be a compact space and f a continuous mapping from (X, \mathcal{T}) into \mathbb{R} . Then the set $f(X)$ has a greatest element and a least element.

Proof. As f is continuous, $f(X)$ is compact. Therefore $f(X)$ is a closed bounded subset of \mathbb{R} . As $f(X)$ is bounded, it has a supremum. Since $f(X)$ is closed, Lemma 3.3.2 implies that the supremum is in $f(X)$. Thus $f(X)$ has a greatest element – namely its supremum. Similarly it can be shown that $f(X)$ has a least element. \square

7.2.15 Proposition. Let a and b be in \mathbb{R} and f a continuous function from $[a, b]$ into \mathbb{R} . Then $f([a, b]) = [c, d]$, for some c and d in \mathbb{R} .

Proof. As $[a, b]$ is connected, $f([a, b])$ is a connected subset of \mathbb{R} and hence is an interval. As $[a, b]$ is compact, $f([a, b])$ is compact. So $f([a, b])$ is a closed bounded interval. Hence

$$f([a, b]) = [c, d]$$

for some c and d in \mathbb{R} . □

Exercises 7.2

1. Which of the following subsets of \mathbb{R} are compact? (Justify your answers.)
 - (i) \mathbb{Z} ;
 - (ii) $\{\frac{\sqrt{2}}{n} : n = 1, 2, 3, \dots\}$;
 - (iii) $\{x : x = \cos y, y \in [0, 1]\}$;
 - (iv) $\{x : x = \tan y, y \in [0, \pi/2)\}$.

2. Which of the following subsets of \mathbb{R}^2 are compact? (Justify your answers.)
 - (i) $\{(x, y) : x^2 + y^2 = 4\}$
 - (ii) $\{(x, y) : x \geq y + 1\}$
 - (iii) $\{(x, y) : 0 \leq x \leq 2, 0 \leq y \leq 4\}$
 - (iv) $\{(x, y) : 0 < x < 2, 0 \leq y \leq 4\}$

3. Let (X, \mathcal{T}) be a compact space. If $\{F_i : i \in I\}$ is a family of closed subsets of X such that $\bigcap_{i \in I} F_i = \emptyset$, prove that there is a finite subfamily

$$F_{i_1}, F_{i_2}, \dots, F_{i_m} \text{ such that } F_{i_1} \cap F_{i_2} \cap \dots \cap F_{i_m} = \emptyset.$$

4. Corollary 4.3.7 says that for real numbers a, b, c and d with $a < b$ and $c < d$,

(i) $(a, b) \not\cong [c, d]$

(ii) $[a, b] \not\cong [c, d]$.

Prove each of these using a compactness argument (rather than a connectedness argument as was done in Corollary 4.3.7).

5. Let (X, \mathcal{T}) and (Y, \mathcal{T}_1) be topological spaces. A mapping $f : (X, \mathcal{T}) \rightarrow (Y, \mathcal{T}_1)$ is said to be a **closed mapping** if for every closed subset A of (X, \mathcal{T}) , $f(A)$ is closed in (Y, \mathcal{T}_1) . A function $f : (X, \mathcal{T}) \rightarrow (Y, \mathcal{T}_1)$ is said to be an **open mapping** if for every open subset A of (X, \mathcal{T}) , $f(A)$ is open in (Y, \mathcal{T}_1) .

(a) Find examples of mappings f which are

(i) open but not closed

(ii) closed but not open

(iii) open but not continuous

(iv) closed but not continuous

(v) continuous but not open

(vi) continuous but not closed.

(b) If (X, \mathcal{T}) and (Y, \mathcal{T}_1) are compact Hausdorff spaces and $f : (X, \mathcal{T}) \rightarrow (Y, \mathcal{T}_1)$ is a continuous mapping, prove that f is a closed mapping.

6. Let $f : (X, \mathcal{T}) \rightarrow (Y, \mathcal{T}_1)$ be a continuous bijection. If (X, \mathcal{T}) is compact and (Y, \mathcal{T}_1) is Hausdorff, prove that f is a homeomorphism.

7. Let $\{C_j : j \in J\}$ be a family of closed compact subsets of a topological space (X, \mathcal{T}) . Prove that $\bigcap_{j \in J} C_j$ is compact.

8. Let n be a positive integer, d the euclidean metric on \mathbb{R}^n , and X a subset of \mathbb{R}^n . Prove that X is bounded in (\mathbb{R}^n, d) if and only if there exists a positive real number M such that for all $\langle x_1, x_2, \dots, x_n \rangle \in X$, $-M \leq x_i \leq M$, $i = 1, 2, \dots, n$.

9. Let $(C[0, 1], d^*)$ be the metric space defined in Example 6.1.6. Let $B = \{f : f \in C[0, 1] \text{ and } d^*(f, 0) \leq 1\}$ where 0 denotes the constant function from $[0, 1]$ into \mathbb{R} which maps every element to zero. (The set B is called the **closed unit ball**.)
- (i) Verify that B is closed and bounded in $(C[0, 1], d^*)$.
 - (ii) Prove that B is not compact. [Hint: Let $\{B_i : i \in I\}$ be the family of all open balls of radius $\frac{1}{2}$ in $(C[0, 1], d^*)$. Then $\{B_i : i \in I\}$ is an open covering of B . Suppose there exists a finite subcovering B_1, B_2, \dots, B_N . Consider the $(N + 1)$ functions $f_\alpha : [0, 1] \rightarrow \mathbb{R}$ given by $f_\alpha(x) = \sin(2^{N-\alpha} \cdot \pi \cdot x)$, $\alpha = 1, 2, \dots, N + 1$.
 - (a) Verify that each $f_\alpha \in B$.
 - (b) Observing that $f_{N+1}(1) = 1$ and $f_m(1) = 0$, for all $m \leq N$, deduce that if $f_{N+1} \in B_1$ then $f_m \notin B_1$, $m = 1, \dots, N$.
 - (c) Observing that $f_N(\frac{1}{2}) = 1$ and $f_m(\frac{1}{2}) = 0$, for all $m \leq N - 1$, deduce that if $f_N \in B_2$ then $f_m \notin B_2$, $m = 1, \dots, N - 1$.
 - (d) Continuing this process, show that f_1, f_2, \dots, f_{N+1} lie in distinct B_i – a contradiction.]
10. Prove that every compact Hausdorff space is a normal space.
- 11.* Let A and B be disjoint compact subsets of a Hausdorff space (X, \mathcal{T}) . Prove that there exist disjoint open sets G and H such that $A \subseteq G$ and $B \subseteq H$.
12. Let (X, \mathcal{T}) be an infinite topological space with the property that every subspace is compact. Prove that (X, \mathcal{T}) is not a Hausdorff space.
13. Prove that every uncountable topological space which is not compact has an uncountable number of subsets which are compact and an uncountable number which are not compact.
14. If (X, \mathcal{T}) is a Hausdorff space such that every proper closed subspace is compact, prove that (X, \mathcal{T}) is compact.

7.3 Postscript

Compactness plays a key role in applications of topology to all branches of analysis. As noted in Remark 7.1.4 it can be thought as a topological generalization of finiteness.

The Generalized Heine-Borel Theorem characterizes the compact subsets of \mathbb{R}^n as those which are closed and bounded.

Compactness is a topological property. Indeed any continuous image of a compact space is compact.

Closed subsets of compact spaces are compact and compact subspaces of Hausdorff spaces are closed.

Exercises 7.2 # 5 introduces the notions of open mappings and closed mappings. Exercises 7.2 #10 notes that a compact Hausdorff space is a normal space (indeed a T_4 -space). That the closed unit ball in each \mathbb{R}^n is compact contrasts with Exercises 7.2 #9. This exercise points out that the closed unit ball in the metric space $(C[0, 1], d^*)$ is not compact. Though we shall not prove it here, it can be shown that a normed vector space is finite-dimensional if and only if its closed unit ball is compact.

Warning. It is unfortunate that “compact” is defined in different ways in different books and some of these are not equivalent to the definition presented here. Firstly some books include Hausdorff in the definition of compact. Some books, particularly older ones, use “compact” to mean a weaker property than ours—what is often called sequentially compact. Finally the term “bikompakt” is often used to mean compact or compact Hausdorff in our sense.

Chapter 8

Finite Products

Introduction

There are three important ways of creating new topological spaces from old ones. They are by forming “subspaces”, “quotient spaces”, and “product spaces”. The next three chapters are devoted to the study of product spaces. In this chapter we investigate finite products and prove Tychonoff’s Theorem. This seemingly innocuous theorem says that any product of compact spaces is compact. So we are led to ask: precisely which subsets of \mathbb{R} are compact? The Heine-Borel Theorem will tell us that the compact subsets of \mathbb{R} are precisely the sets which are both closed and bounded.

As we go farther into our study of topology, we shall see that compactness plays a crucial role. This is especially so of applications of topology to analysis.

8.1 The Product Topology

If X_1, X_2, \dots, X_n are sets then the **product** $X_1 \times X_2 \times \dots \times X_n$ is the set consisting of all the ordered n -tuples $\langle x_1, x_2, \dots, x_n \rangle$, where $x_i \in X_i$, $i = 1, \dots, n$.

The problem we now discuss is:

Given topological spaces $(X_1, \mathcal{T}_1), (X_2, \mathcal{T}_2), \dots, (X_n, \mathcal{T}_n)$ how do we define a reasonable topology \mathcal{T} on the product set $X_1 \times X_2 \times \dots \times X_n$?

An obvious (but incorrect!) candidate for \mathcal{T} is the set of all sets $O_1 \times O_2 \times \dots \times O_n$, where $O_i \in \mathcal{T}_i$, $i = 1, \dots, n$. Unfortunately this is not a topology.

For example, if $n = 2$ and $(X, \mathcal{T}_1) = (X, \mathcal{T}_2) = \mathbb{R}$ then \mathcal{T} would contain the rectangles $(0, 1) \times (0, 1)$ and $(2, 3) \times (2, 3)$ but not the set $[(0, 1) \times (0, 1)] \cup [(2, 3) \times (2, 3)]$, since this is not $O_1 \times O_2$ for any choice of O_1 and O_2 .

[If it were $O_1 \times O_2$ for some O_1 and O_2 , then $\frac{1}{2} \in (0, 1) \subseteq O_1$ and $2\frac{1}{2} \in (2, 3) \subseteq O_2$ and so the ordered pair $\langle \frac{1}{2}, 2\frac{1}{2} \rangle \in O_1 \times O_2$ but $\langle \frac{1}{2}, 2\frac{1}{2} \rangle \notin [(0, 1) \times (0, 1)] \cup [(2, 3) \times (2, 3)]$.] Thus \mathcal{T} is not closed under unions and so is not a topology.

However we have already seen how to put a topology (the euclidean topology) on $\mathbb{R}^2 = \mathbb{R} \times \mathbb{R}$. This was done in Example 2.2.9. Indeed this example suggests how to define the product topology in general.

8.1.1 Definitions. Let $(X_1, \mathcal{T}_1), (X_2, \mathcal{T}_2), \dots, (X_n, \mathcal{T}_n)$ be topological spaces. Then the **product topology** \mathcal{T} on the set $X_1 \times X_2 \times \dots \times X_n$ is the topology having the family $\{O_1 \times O_2 \times \dots \times O_n, O_i \in \mathcal{T}_i, i = 1, \dots, n\}$ as a basis. The set $X_1 \times X_2 \times \dots \times X_n$ with the topology \mathcal{T} is said to be the **product of the spaces** $(X_1, \mathcal{T}_1), (X_2, \mathcal{T}_2), \dots, (X_n, \mathcal{T}_n)$ and is denoted by $(X_1 \times X_2 \times \dots \times X_n, \mathcal{T})$ or $(X_1, \mathcal{T}_1) \times (X_2, \mathcal{T}_2) \times \dots \times (X_n, \mathcal{T}_n)$.

Of course it must be verified that the family $\{O_1 \times O_2 \times \dots \times O_n : O_i \in \mathcal{T}_i, i = 1, \dots, n\}$ is a basis for a topology; that is, it satisfies the conditions of Proposition 2.2.8. (This is left as an exercise for you.)

8.1.2 Proposition. Let $\mathcal{B}_1, \mathcal{B}_2, \dots, \mathcal{B}_n$ be bases for topological spaces $(X_1, \mathcal{T}_1), (X_2, \mathcal{T}_2), \dots, (X_n, \mathcal{T}_n)$, respectively. Then the family $\{O_1 \times O_2 \times \dots \times O_n : O_i \in \mathcal{B}_i, i = 1, \dots, n\}$ is a basis for the product topology on $X_1 \times X_2 \times \dots \times X_n$.

The proof of Proposition 8.1.2 is straightforward and is also left as an exercise for you.

8.1.3 Observations (i) We now see that the euclidean topology on \mathbb{R}^n , $n \geq 2$, is just the product topology on the set $\mathbb{R} \times \mathbb{R} \times \dots \times \mathbb{R} = \mathbb{R}^n$. (See Example 2.2.9 and Remark 2.2.10.)

(ii) It is clear from Definitions 8.1.1 that any product of open sets is an open set or more precisely: if O_1, O_2, \dots, O_n are open subsets of topological spaces $(X_1, \mathcal{T}_1), (X_2, \mathcal{T}_2), \dots, (X_n, \mathcal{T}_n)$, respectively, then $O_1 \times O_2 \times \dots \times O_n$ is an open subset of $(X_1, \mathcal{T}_1) \times (X_2, \mathcal{T}_2) \times \dots \times (X_n, \mathcal{T}_n)$. The next proposition says that any product of closed sets is a closed set.

8.1.4 Proposition. Let C_1, C_2, \dots, C_n be closed subsets of the topological spaces $(X_1, \mathcal{T}_1), (X_2, \mathcal{T}_2), \dots, (X_n, \mathcal{T}_n)$, respectively. Then $C_1 \times C_2 \times \dots \times C_n$ is a closed subset of the product space $(X_1 \times X_2 \times \dots \times X_n, \mathcal{T})$.

Proof. Observe that

$$\begin{aligned} & (X_1 \times X_2 \times \dots \times X_n) \setminus (C_1 \times C_2 \times \dots \times C_n) \\ = & [(X_1 \setminus C_1) \times X_2 \times \dots \times X_n] \cup [X_1 \times (X_2 \setminus C_2) \times X_3 \times \dots \times X_n] \cup \\ & \dots \cup [X_1 \times X_2 \times \dots \times X_{n-1} \times (X_n \setminus C_n)] \end{aligned}$$

which is a union of open sets (as a product of open sets is open) and so is an open set in $(X_1, \mathcal{T}_1) \times (X_2, \mathcal{T}_2) \times \dots \times (X_n, \mathcal{T}_n)$. Therefore its complement, $C_1 \times C_2 \times \dots \times C_n$, is a closed set, as required. \square

Exercises 8.1

1. Prove Proposition 8.1.2.
2. If $(X_1, \mathcal{T}_1), (X_2, \mathcal{T}_2), \dots, (X_n, \mathcal{T}_n)$ are discrete spaces, prove that the product space $(X_1, \mathcal{T}_1) \times (X_2, \mathcal{T}_2) \times \cdots \times (X_n, \mathcal{T}_n)$ is also a discrete space.
3. Let X_1 and X_2 be infinite sets and \mathcal{T}_1 and \mathcal{T}_2 the finite-closed topology on X_1 and X_2 , respectively. Show that the product topology, \mathcal{T} , on $X_1 \times X_2$ is not the finite-closed topology.
4. Prove that the product of any finite number of indiscrete spaces is an indiscrete space.
5. Prove that the product of any finite number of Hausdorff spaces is Hausdorff.
6. Let (X, \mathcal{T}) be a topological space and $D = \{(x, x) : x \in X\}$ the diagonal in the product space $(X, \mathcal{T}) \times (X, \mathcal{T}) = (X \times X, \mathcal{T}_1)$. Prove that (X, \mathcal{T}) is a Hausdorff space if and only if D is closed in $(X \times X, \mathcal{T}_1)$.
7. Let $(X_1, \mathcal{T}_1), (X_2, \mathcal{T}_2)$ and (X_3, \mathcal{T}_3) be topological spaces. Prove that
$$[(X_1, \mathcal{T}_1) \times (X_2, \mathcal{T}_2)] \times (X_3, \mathcal{T}_3) \cong (X_1, \mathcal{T}_1) \times (X_2, \mathcal{T}_2) \times (X_3, \mathcal{T}_3).$$
8. (i) Let (X_1, \mathcal{T}_1) and (X_2, \mathcal{T}_2) be topological spaces. Prove that
$$(X_1, \mathcal{T}_1) \times (X_2, \mathcal{T}_2) \cong (X_2, \mathcal{T}_2) \times (X_1, \mathcal{T}_1).$$
(ii) Generalize the above result to products of any finite number of topological spaces.

9. Let C_1, C_2, \dots, C_n be subsets of the topological spaces $(X_1, \mathcal{T}_1), (X_2, \mathcal{T}_2), \dots, (X_n, \mathcal{T}_n)$, respectively, so that $C_1 \times C_2 \times \dots \times C_n$ is a subset of $(X_1, \mathcal{T}_1) \times (X_2, \mathcal{T}_2) \times \dots \times (X_n, \mathcal{T}_n)$. Prove each of the following statements.
- (i) $(C_1 \times C_2 \times \dots \times C_n)' \supseteq C_1' \times C_2' \times \dots \times C_n'$;
 - (ii) $\overline{C_1 \times C_2 \times \dots \times C_n} = \overline{C_1} \times \overline{C_2} \times \dots \times \overline{C_n}$;
 - (iii) if C_1, C_2, \dots, C_n are dense in $(X_1, \mathcal{T}_1), (X_2, \mathcal{T}_2), \dots, (X_n, \mathcal{T}_n)$, respectively, then $C_1 \times C_2 \times \dots \times C_n$ is dense in the product space $(X_1, \mathcal{T}_1) \times (X_2, \mathcal{T}_2) \times \dots \times (X_n, \mathcal{T}_n)$;
 - (iv) if $(X_1, \mathcal{T}_1), (X_2, \mathcal{T}_2), \dots, (X_n, \mathcal{T}_n)$ are separable spaces, then $(X_1, \mathcal{T}_1) \times (X_2, \mathcal{T}_2) \times \dots \times (X_n, \mathcal{T}_n)$ is a separable space;
 - (v) for each $n \geq 1$, \mathbb{R}^n is a separable space.
10. Show that the product of a finite number of T_1 -spaces is a T_1 -space.
11. If $(X_1, \mathcal{T}_1), \dots, (X_n, \mathcal{T}_n)$ satisfy the second axiom of countability, show that $(X_1, \mathcal{T}_1) \times (X_2, \mathcal{T}_2) \times \dots \times (X_n, \mathcal{T}_n)$ satisfies the second axiom of countability also.
12. Let $(\mathbb{R}, \mathcal{T}_1)$ be the Sorgenfrey line, defined in Exercises 3.2 #11, and $(\mathbb{R}^2, \mathcal{T}_2)$ be the product space $(\mathbb{R}, \mathcal{T}_1) \times (\mathbb{R}, \mathcal{T}_1)$. Prove the following statements.
- (i) $\{\langle x, y \rangle : a \leq x < b, c \leq y < d, a, b, c, d \in \mathbb{R}\}$ is a basis for the topology \mathcal{T}_2 .
 - (ii) $(\mathbb{R}^2, \mathcal{T}_2)$ is a regular separable totally disconnected Hausdorff space.
 - (iii) Let $L = \{\langle x, y \rangle : x, y \in \mathbb{R} \text{ and } x + y = 0\}$. Then the line L is closed in the euclidean topology on the plane and hence also in $(\mathbb{R}^2, \mathcal{T}_2)$.
 - (iv) If \mathcal{T}_3 is the subspace topology induced on the line L by \mathcal{T}_2 , then \mathcal{T}_3 is the discrete topology, and hence (L, \mathcal{T}_3) is not a separable space. [As (L, \mathcal{T}_3) is a closed subspace of the separable space $(\mathbb{R}^2, \mathcal{T}_2)$, we now know that **a closed subspace of a separable space is not necessarily separable.**]
- [Hint: show that $L \cap \{\langle x, y \rangle : a \leq x < a + 1, -a \leq y < -a + 1, a \in \mathbb{R}\}$ is a singleton set.]

8.2 Projections onto Factors of a Product

Before proceeding to our next result we need a couple of definitions.

8.2.1 Definitions. Let \mathcal{T}_1 and \mathcal{T}_2 be topologies on a set X . Then \mathcal{T}_1 is said to be a **finer topology** than \mathcal{T}_2 (and \mathcal{T}_2 is said to be a **coarser topology** than \mathcal{T}_1) if $\mathcal{T}_1 \supseteq \mathcal{T}_2$.

8.2.2 Example. The discrete topology on a set X is finer than any other topology on X . The indiscrete topology on X is coarser than any other topology on X . [See also Exercises 5.1 #10.] \square

8.2.3 Definitions. Let (X, \mathcal{T}) and (Y, \mathcal{T}_1) be topological spaces and f a mapping from X into Y . Then f is said to be an **open mapping** if for every $A \in \mathcal{T}$, $f(A) \in \mathcal{T}_1$. The mapping f is said to be a **closed mapping** if for every closed set B in (X, \mathcal{T}) , $f(B)$ is closed in (Y, \mathcal{T}_1) .

8.2.4 Remark. In Exercises 7.2 #5, you were asked to show that none of the conditions “continuous mapping”, “open mapping”, “closed mapping”, implies either of the other two conditions. Indeed no two of these conditions taken together implies the third. (Find examples to verify this.) \square

8.2.5 Proposition. Let $(X, \mathcal{T}_1), (X_2, \mathcal{T}_2), \dots, (X_n, \mathcal{T}_n)$ be topological spaces and $(X_1 \times X_2 \times \cdots \times X_n, \mathcal{T})$ their product space.

For each $i \in \{1, \dots, n\}$, let $p_i : X_1 \times X_2 \times \cdots \times X_n \rightarrow X_i$ be the projection mapping; that is, $p_i(\langle x_1, x_2, \dots, x_i, \dots, x_n \rangle) = x_i$, for each $\langle x_1, x_2, \dots, x_i, \dots, x_n \rangle \in X_1 \times X_2 \times \cdots \times X_n$. Then

- (i) each p_i is a continuous surjective open mapping, and
- (ii) \mathcal{T} is the coarsest topology on the set $X_1 \times X_2 \times \cdots \times X_n$ such that each p_i is continuous.

Proof. Clearly each p_i is surjective. To see that each p_i is continuous, let U be any open set in (X_i, \mathcal{T}_i) . Then

$$p_i^{-1}(U) = X_1 \times X_2 \times \cdots \times X_{i-1} \times U \times X_{i+1} \times \cdots \times X_n$$

which is a product of open sets and so is open in $(X_1 \times X_2 \times \cdots \times X_n, \mathcal{T})$. Hence each p_i is continuous.

To show that p_i is an open mapping it suffices to verify that for each basic open set $U_1 \times U_2 \times \cdots \times U_n$, where U_j is open in (X_j, \mathcal{T}_j) , for $j = 1, \dots, n$, the set $p_i(U_1 \times U_2 \times \cdots \times U_n)$ is open in (X_i, \mathcal{T}_i) . But $p_i(U_1 \times U_2 \times \cdots \times U_n) = U_i$ which is, of course, open in (X_i, \mathcal{T}_i) . So each p_i is an open mapping. We have now verified part (i) of the proposition.

Now let \mathcal{T}' be any topology on the set $X_1 \times X_2 \times \cdots \times X_n$ such that each projection mapping $p_i : (X_1 \times X_2 \times \cdots \times X_n, \mathcal{T}') \rightarrow (X_i, \mathcal{T}_i)$ is continuous. We have to show that $\mathcal{T}' \supseteq \mathcal{T}$.

Recalling the definition of the basis for the topology \mathcal{T} (given in Definition 8.1.1) it suffices to show that if O_1, O_2, \dots, O_n are open sets in $(X_1, \mathcal{T}_1), (X_2, \mathcal{T}_2), \dots, (X_n, \mathcal{T}_n)$ respectively, then $O_1 \times O_2 \times \cdots \times O_n \in \mathcal{T}'$. To show this, observe that as p_i is continuous, $p_i^{-1}(O_i) \in \mathcal{T}'$, for each $i = 1, \dots, n$. Now

$$p_i^{-1}(O_i) = X_1 \times X_2 \times \cdots \times X_{i-1} \times O_i \times X_{i+1} \times \cdots \times X_n,$$

so that

$$\bigcap_{i=1}^n p_i^{-1}(O_i) = O_1 \times O_2 \times \cdots \times O_n.$$

Then $p_i^{-1}(O_i) \in \mathcal{T}'$ for $i = 1, \dots, n$, implies $\bigcap_{i=1}^n p_i^{-1}(O_i) \in \mathcal{T}'$; that is, $O_1 \times O_2 \times \cdots \times O_n \in \mathcal{T}'$, as required. \square

8.2.6 Remark. Proposition 8.2.5 (ii) gives us another way of defining the product topology. Given topological spaces $(X_1, \mathcal{T}_1), (X_2, \mathcal{T}_2), \dots, (X_n, \mathcal{T}_n)$ the product topology can be defined as the coarsest topology on $X_1 \times X_2 \times \dots \times X_n$ such that each projection $p_i : X_1 \times X_2 \times \dots \times X_n \rightarrow X_i$ is continuous. This observation will be of greater significance in the next section when we proceed to a discussion of products of an infinite number of topological spaces. \square

8.2.7 Corollary. For $n \geq 2$, the projection mappings of \mathbb{R}^n onto \mathbb{R} are continuous open mappings. \square

8.2.8 Proposition. Let $(X_1, \mathcal{T}_1), (X_2, \mathcal{T}_2), \dots, (X_n, \mathcal{T}_n)$ be topological spaces and $(X_1 \times X_2 \times \dots \times X_n, \mathcal{T})$ the product space. Then each (X_i, \mathcal{T}_i) is homeomorphic to a subspace of $(X_1 \times X_2 \times \dots \times X_n, \mathcal{T})$.

Proof. For each j , let a_j be any (fixed) element in X_j . For each i , define a mapping $f_i: (X_i, \mathcal{T}_i) \rightarrow (X_1 \times X_2 \times \dots \times X_n, \mathcal{T})$ by

$$f_i(x) = \langle a_1, a_2, \dots, a_{i-1}, x, a_{i+1}, \dots, a_n \rangle.$$

We claim that $f_i: (X_i, \mathcal{T}_i) \rightarrow (f_i(X_i), \mathcal{T}')$ is a homeomorphism, where \mathcal{T}' is the topology induced on $f_i(X_i)$ by \mathcal{T} . Clearly this mapping is one-to-one and onto. Let $U \in \mathcal{T}_i$. Then

$$\begin{aligned} f_i(U) &= \{a_1\} \times \{a_2\} \times \dots \times \{a_{i-1}\} \times U \times \{a_{i+1}\} \times \dots \times \{a_n\} \\ &= (X_1 \times X_2 \times \dots \times X_{i-1} \times U \times X_{i+1} \times \dots \times X_n) \cap \\ &\quad (\{a_1\} \times \{a_2\} \times \dots \times \{a_{i-1}\} \times X_i \times \{a_{i+1}\} \times \dots \times \{a_n\}) \\ &= (X_1 \times X_2 \times \dots \times X_{i-1} \times U \times X_{i+1} \times \dots \times X_n) \cap f_i(X_i) \\ &\in \mathcal{T}' \end{aligned}$$

since $X_1 \times X_2 \times \dots \times X_{i-1} \times U \times X_{i+1} \times \dots \times X_n \in \mathcal{T}$. So $U \in \mathcal{T}_i$ implies that $f_i(U) \in \mathcal{T}'$.

Finally, observe that the family

$$\{(U_1 \times U_2 \times \dots \times U_n) \cap f_i(X_i) : U_i \in \mathcal{T}_i, i = 1, \dots, n\}$$

is a basis for \mathcal{T}' , so to prove that f_i is continuous it suffices to verify that the inverse image under f_i of every member of this family is open in (X_i, \mathcal{T}_i) . But

$$\begin{aligned} f_i^{-1}[(U_1 \times U_2 \times \dots \times U_n) \cap f_i(X_i)] &= f_i^{-1}(U_1 \times U_2 \times \dots \times U_n) \cap f_i^{-1}(f_i(X_i)) \\ &= \begin{cases} U_i \cap X_i, & \text{if } a_j \in U_j, j \neq i \\ \emptyset, & \text{if } a_j \notin U_j, \text{ for some } j \neq i. \end{cases} \end{aligned}$$

As $U_i \cap X_i = U_i \in \mathcal{T}_i$ and $\emptyset \in \mathcal{T}_i$ we infer that f_i is continuous, and so we have the required result. \square

Notation. If X_1, X_2, \dots, X_n are sets then the product $X_1 \times X_2 \times \dots \times X_n$ is denoted by $\prod_{i=1}^n X_i$. If $(X_1, \mathcal{T}_1), (X_2, \mathcal{T}_2), \dots, (X_n, \mathcal{T}_n)$ are topological spaces, then the product space $(X_1, \mathcal{T}_1) \times (X_2, \mathcal{T}_2) \times \dots \times (X_n, \mathcal{T}_n)$ is denoted by $\prod_{i=1}^n (X_i, \mathcal{T}_i)$. \square

Exercises 8.2

1. Prove that the euclidean topology on \mathbb{R} is finer than the finite-closed topology.
2. Let (X_i, \mathcal{T}_i) be a topological space, for $i = 1, \dots, n$. Prove that
 - (i) if $\prod_{i=1}^n (X_i, \mathcal{T}_i)$ is connected, then each (X_i, \mathcal{T}_i) is connected;
 - (ii) if $\prod_{i=1}^n (X_i, \mathcal{T}_i)$ is compact, then each (X_i, \mathcal{T}_i) is compact;
 - (iii) if $\prod_{i=1}^n (X_i, \mathcal{T}_i)$ is path-connected, then each (X_i, \mathcal{T}_i) is path-connected;
 - (iv) if $\prod_{i=1}^n (X_i, \mathcal{T}_i)$ is Hausdorff, then each (X_i, \mathcal{T}_i) is Hausdorff;
 - (v) if $\prod_{i=1}^n (X_i, \mathcal{T}_i)$ is a T_1 -space, then each (X_i, \mathcal{T}_i) is a T_1 -space.

3. Let (Y, \mathcal{T}) and (X_i, \mathcal{T}_i) , $i = 1, 2, \dots, n$ be topological spaces. Further for each i , let f_i be a mapping of (Y, \mathcal{T}) into (X_i, \mathcal{T}_i) . Prove that the mapping $f: (Y, \mathcal{T}) \rightarrow \prod_{i=1}^n (X_i, \mathcal{T}_i)$, given by

$$f(y) = \langle f_1(y), f_2(y), \dots, f_n(y) \rangle,$$

is continuous if and only if every f_i is continuous.

[Hint: Observe that $f_i = p_i \circ f$, where p_i is the projection mapping of $\prod_{j=1}^n (X_j, \mathcal{T}_j)$ onto (X_i, \mathcal{T}_i) .]

4. Let (X, d_1) and (Y, d_2) be metric spaces. Further let e be the metric on $X \times Y$ defined in Exercises 6.1 #4. Also let \mathcal{T} be the topology induced on $X \times Y$ by e . If d_1 and d_2 induce the topologies \mathcal{T}_1 and \mathcal{T}_2 on X and Y , respectively, and \mathcal{T}_3 is the product topology of $(X, \mathcal{T}_1) \times (Y, \mathcal{T}_2)$, prove that $\mathcal{T} = \mathcal{T}_3$. [This shows that [the product of any two metrizable spaces is metrizable](#).]
5. Let $(X_1, \mathcal{T}_1), (X_2, \mathcal{T}_2), \dots, (X_n, \mathcal{T}_n)$ be topological spaces. Prove that $\prod_{i=1}^n (X_i, \mathcal{T}_i)$ is a metrizable space if and only if each (X_i, \mathcal{T}_i) is metrizable.

[Hint: Use Exercises 6.1 #6, which says that every subspace of a metrizable space is metrizable, and Exercise 4 above.]

8.3 Tychonoff's Theorem for Finite Products

8.3.1 Theorem. (Tychonoff's Theorem for Finite Products) If $(X_1, \mathcal{T}_1), (X_2, \mathcal{T}_2), \dots, (X_n, \mathcal{T}_n)$ are compact spaces, then $\prod_{i=1}^n (X_i, \mathcal{T}_i)$ is a compact space.

Proof. Consider first the product of two compact spaces (X, \mathcal{T}_1) and (Y, \mathcal{T}_2) . Let $U_i, i \in I$ be any opening covering of $X \times Y$. Then for each $x \in X$ and $y \in Y$, there exists an $i \in I$ such that $\langle x, y \rangle \in U_i$. So there is a basic open set $V(x, y) \times W(x, y)$, such that $V(x, y) \in \mathcal{T}_1, W(x, y) \in \mathcal{T}_2$ and $\langle x, y \rangle \in V(x, y) \times W(x, y) \subseteq U_i$.

As $\langle x, y \rangle$ ranges over all points of $X \times Y$ we obtain an open covering $V(x, y) \times W(x, y), x \in X, y \in Y$, of $X \times Y$ such that each $V(x, y) \times W(x, y)$ is a subset of some $U_i, i \in I$. Thus to prove $(X, \mathcal{T}_1) \times (Y, \mathcal{T}_2)$ is compact it suffices to find a finite subcovering of the open covering $V(x, y) \times W(x, y), x \in X, y \in Y$.

Now fix $x_0 \in X$ and consider the subspace $\{x_0\} \times Y$ of $X \times Y$. As seen in Proposition 8.2.8 this subspace is homeomorphic to (Y, \mathcal{T}_2) and so is compact. As $V(x_0, y) \times W(x_0, y), y \in Y$, is an open covering of $\{x_0\} \times Y$ it has a finite subcovering:

$$V(x_0, y_1) \times W(x_0, y_1), V(x_0, y_2) \times W(x_0, y_2), \dots, V(x_0, y_m) \times W(x_0, y_m).$$

Put $V(x_0) = V(x_0, y_1) \cap V(x_0, y_2) \cap \dots \cap V(x_0, y_m)$. Then we see that the set $V(x_0) \times Y$ is contained in the union of a finite number of sets of the form $V(x_0, y) \times W(x_0, y), y \in Y$.

Thus to prove $X \times Y$ is compact it suffices to show that $X \times Y$ is contained in a finite union of sets of the form $V(x) \times Y$. As each $V(x)$ is an open set containing $x \in X$, the family $V(x), x \in X$, is an open covering of the compact space (X, \mathcal{T}_1) . Therefore there exist x_1, x_2, \dots, x_k such that $X \subseteq V(x_1) \cup V(x_2) \cup \dots \cup V(x_k)$. Thus $X \times Y \subseteq (V(x_1) \times Y) \cup (V(x_2) \times Y) \cup \dots \cup (V(x_k) \times Y)$, as required. Hence $(X, \mathcal{T}_1) \times (Y, \mathcal{T}_2)$ is compact.

The proof is completed by induction. Suppose that the product of any N compact spaces is compact. Consider the product $(X_1, \mathcal{T}_1) \times (X_2, \mathcal{T}_2) \times \dots \times (X_{N+1}, \mathcal{T}_{N+1})$ of compact spaces $(X_i, \mathcal{T}_i), i = 1, \dots, N + 1$. Then

$$(X_1, \mathcal{T}_1) \times (X_2, \mathcal{T}_2) \times \dots \times (X_{N+1}, \mathcal{T}_{N+1}) \cong [(X_1, \mathcal{T}_1) \times \dots \times (X_N, \mathcal{T}_N)] \times (X_{N+1}, \mathcal{T}_{N+1}).$$

By our inductive hypothesis $(X_1, \mathcal{T}_1) \times \dots \times (X_N, \mathcal{T}_N)$ is compact, so the right-hand side is the product of two compact spaces and thus is compact. Therefore the left-hand side is also compact. This completes the induction and the proof of the theorem. \square

Using Proposition 7.2.1 and 8.2.5 (i) we immediately obtain:

8.3.2 Proposition. (Converse of Tychonoff's Theorem) Let $(X_1, \mathcal{T}_1), (X_2, \mathcal{T}_2), \dots, (X_n, \mathcal{T}_n)$ be topological spaces. If $\prod_{i=1}^n (X_i, \mathcal{T}_i)$ is compact, then each (X_i, \mathcal{T}_i) is compact. \square

We can now prove the previously stated Theorem 7.2.13.

8.3.3 Theorem. (Generalized Heine-Borel Theorem) A subset of \mathbb{R}^n , $n \geq 1$ is compact if and only if it is closed and bounded.

Proof. That any compact subset of \mathbb{R}^n is bounded can be proved in an analogous fashion to Proposition 7.2.8. Thus by Proposition 7.2.5 any compact subset of \mathbb{R}^n is closed and bounded.

Conversely let S be any closed bounded subset of \mathbb{R}^n . Then, by Exercises 7.2 #8, S is a closed subset of the product

$$\overbrace{[-M, M] \times [-M, M] \times \cdots \times [-M, M]}^{n \text{ terms}}$$

for some positive real number M . As each closed interval $[-M, M]$ is compact, by Corollary 7.2.3, Tychonoff's Theorem implies that the product space

$$[-M, M] \times [-M, M] \times \cdots \times [-M, M]$$

is also compact. As S is a closed subset of a compact set, it too is compact. \square

8.3.4 Example. Define the subspace \mathbb{S}^1 of \mathbb{R}^2 by

$$\mathbb{S}^1 = \{ \langle x, y \rangle : x^2 + y^2 = 1 \}.$$

Then \mathbb{S}^1 is a closed bounded subset of \mathbb{R}^2 and thus is compact.

Similarly we define the **n-sphere** \mathbb{S}^n as the subspace of \mathbb{R}^{n+1} given by

$$\mathbb{S}^n = \{ \langle x_1, x_2, \dots, x_{n+1} \rangle : x_1^2 + x_2^2 + \cdots + x_{n+1}^2 = 1 \}.$$

Then \mathbb{S}^n is a closed bounded subset of \mathbb{R}^{n+1} and so is compact. \square

8.3.5 Example. The subspace $\mathbb{S}^1 \times [0, 1]$ of \mathbb{R}^3 is the product of two compact spaces and so is compact. (Convince yourself that $\mathbb{S}^1 \times [0, 1]$ is the surface of a cylinder.) \square

Exercises 8.3

1. A topological space (X, \mathcal{T}) is said to be **locally compact** if each point $x \in X$ has at least one neighbourhood which is compact. Prove that
 - (i) Every compact space is locally compact.
 - (ii) \mathbb{R} and \mathbb{Z} are locally compact (but not compact).
 - (iii) Every discrete space is locally compact.
 - (iv) If $(X_1, \mathcal{T}_1), (X_2, \mathcal{T}_2), \dots, (X_n, \mathcal{T}_n)$ are locally compact spaces, then $\prod_{i=1}^n (X_i, \mathcal{T}_i)$ is locally compact.
 - (v) Every closed subspace of a locally compact space is locally compact.
 - (vi) A continuous image of a locally compact space is not necessarily locally compact.
 - (vii) If f is a continuous open mapping of a locally compact space (X, \mathcal{T}) onto a topological space (Y, \mathcal{T}_1) , then (Y, \mathcal{T}_1) is locally compact.
 - (viii) If $(X_1, \mathcal{T}_1), (X_2, \mathcal{T}_2), \dots, (X_n, \mathcal{T}_n)$ are topological spaces such that $\prod_{i=1}^n (X_i, \mathcal{T}_i)$ is locally compact, then each (X_i, \mathcal{T}_i) is locally compact.

- 2.* Let (Y, \mathcal{T}_1) be a locally compact subspace of the Hausdorff space (X, \mathcal{T}) . If Y is dense in (X, \mathcal{T}) , prove that Y is open in (X, \mathcal{T}) .
 [Hint: Use Exercises 3.2 #9]

8.4 Products and Connectedness

8.4.1 Definition. Let (X, \mathcal{T}) be a topological space and let x be any point in X . The **component in X of x** , $C_X(x)$, is defined to be the union of all connected subsets of X which contain x .

8.4.2 Proposition. Let x be any point in a topological space (X, \mathcal{T}) . Then $C_X(x)$ is connected.

Proof. Let $\{C_i : i \in I\}$ be the family of all connected subsets of (X, \mathcal{T}) which contain x . (Observe that $\{x\} \in \{C_i : i \in I\}$.) Then $C_X(x) = \bigcup_{i \in I} C_i$.

Let O be a subset of $C_X(x)$ which is clopen in the topology induced on $C_X(x)$ by \mathcal{T} . Then $O \cap C_i$ is clopen in the induced topology on C_i , for each i .

But as each C_i is connected, $O \cap C_i = C_i$ or \emptyset , for each i . If $O \cap C_j = C_j$ for some $j \in I$, then $x \in O$. So, in this case, $O \cap C_i \neq \emptyset$, for all $i \in I$ as each C_i contains x . Therefore $O \cap C_i = C_i$, for all $i \in I$ or $O \cap C_i = \emptyset$, for all $i \in I$; that is, $O = C_X(x)$ or $O = \emptyset$.

So $C_X(x)$ has no proper non-empty clopen subset and hence is connected. \square

8.4.3 Remark. We see from Definition 8.4.1 and Proposition 8.4.2 that $C_X(x)$ is the largest connected subset of X which contains x . \square

8.4.4 Lemma. Let a and b be points in a topological space (X, \mathcal{T}) . If there exists a connected set C containing both a and b then $C_X(a) = C_X(b)$.

Proof. By Definition 8.4.1, $C_X(a) \supseteq C$ and $C_X(b) \supseteq C$. Therefore $a \in C_X(b)$.

By Proposition 8.4.2, $C_X(b)$ is connected and so is a connected set containing a . Thus, by Definition 8.4.1, $C_X(a) \supseteq C_X(b)$.

Similarly $C_X(b) \supseteq C_X(a)$, and we have shown that $C_X(a) = C_X(b)$. \square

8.4.5 Proposition. Let $(X_1, \mathcal{T}_1), (X_2, \mathcal{T}_2), \dots, (X_n, \mathcal{T}_n)$ be topological spaces. Then $\prod_{i=1}^n (X_i, \mathcal{T}_i)$ is connected if and only if each (X_i, \mathcal{T}_i) is connected.

Proof. To show that the product of a finite number of connected spaces is connected, it suffices to prove that the product of any two connected spaces is connected, as the result then follows by induction.

So let (X, \mathcal{T}) and (Y, \mathcal{T}_1) be connected spaces and $\langle x_0, y_0 \rangle$ any point in the product space $(X \times Y, \mathcal{T})$. Let $\langle x_1, y_1 \rangle$ be any other point in $X \times Y$. Then the subspace $\{x_0\} \times Y$ of $(X \times Y, \mathcal{T})$ is homeomorphic to the connected space (Y, \mathcal{T}_1) and so is connected.

Similarly the subspace $X \times \{y_1\}$ is connected. Furthermore, $\langle x_0, y_1 \rangle$ lies in the connected space $\{x_0\} \times Y$, so $C_{X \times Y}(\langle x_0, y_1 \rangle) \supseteq \{x_0\} \times Y \ni \langle x_0, y_0 \rangle$, while $\langle x_0, y_1 \rangle \in X \times \{y_1\}$, and so $C_{X \times Y}(\langle x_0, y_1 \rangle) \supseteq X \times \{y_1\} \ni \langle x_1, y_1 \rangle$.

Thus $\langle x_0, y_0 \rangle$ and $\langle x_1, y_1 \rangle$ lie in the connected set $C_{X \times Y}(\langle x_0, y_1 \rangle)$, and so by Lemma 8.4.4, $C_{X \times Y}(\langle x_0, y_0 \rangle) = C_{X \times Y}(\langle x_1, y_1 \rangle)$. In particular, $\langle x_1, y_1 \rangle \in C_{X \times Y}(\langle x_0, y_0 \rangle)$. As $\langle x_1, y_1 \rangle$ was an arbitrary point in $X \times Y$, we have that $C_{X \times Y}(\langle x_0, y_0 \rangle) = X \times Y$. Hence $(X \times Y, \mathcal{T})$ is connected.

Conversely if $\prod_{i=1}^n (X_i, \mathcal{T}_i)$ is connected then Propositions 8.2.5 and 5.2.1 imply that each (X_i, \mathcal{T}_i) is connected. \square

8.4.6 Remark. In Exercises 5.2 #9 the following result appears: For any point x in any topological space (X, \mathcal{T}) , the component $C_X(x)$ is a closed set. \square

8.4.7 Definition. A topological space is said to be a **continuum** if it is compact and connected.

As an immediate consequence of Theorem 8.3.1 and Propositions 8.4.5 and 8.3.2 we have the following proposition.

8.4.8 Proposition. Let $(X_1, \mathcal{T}_1), (X_2, \mathcal{T}_2), \dots, (X_n, \mathcal{T}_n)$ be topological spaces. Then $\prod_{i=1}^n (X_i, \mathcal{T}_i)$ is a continuum if and only if each (X_i, \mathcal{T}_i) is a continuum. \square

Exercises 8.4

1. A topological space (X, \mathcal{T}) is said to be a **compactum** if it is compact and metrizable. Let $(X_1, \mathcal{T}_1), (X_2, \mathcal{T}_2), \dots, (X_n, \mathcal{T}_n)$ be topological spaces. Using Exercises 8.2#5, prove that $\prod_{i=1}^n (X_i, \mathcal{T}_i)$ is a compactum if and only if each (X_i, \mathcal{T}_i) is a compactum.
2. Let (X, d) be a metric space and \mathcal{T} the topology induced on X by d .
 - (i) Prove that the function d from the product space $(X, \mathcal{T}) \times (X, \mathcal{T})$ into \mathbb{R} is continuous.
 - (ii) Using (i) show that if the metrizable space (X, \mathcal{T}) is connected and X has at least 2 points, then X has the uncountable number of points.
3. If (X, \mathcal{T}) and (Y, \mathcal{T}_1) are path-connected spaces, prove that the product space $(X, \mathcal{T}) \times (Y, \mathcal{T}_1)$ is path-connected.
4. (i) Let $x = (x_1, x_2, \dots, x_n)$ be any point in the product space $(Y, \mathcal{T}) = \prod_{i=1}^n (X_i, \mathcal{T}_i)$. Prove that $C_Y(x) = C_{X_1}(x_1) \times C_{X_2}(x_2) \times \dots \times C_{X_n}(x_n)$.
 - (ii) Deduce from (i) and Exercises 5.2 #10 that $\prod_{i=1}^n (X_i, \mathcal{T}_i)$ is totally disconnected if and only if each (X_i, \mathcal{T}_i) is totally disconnected.

5. Let G be a group and \mathcal{T} be a topology on the set G . Then (G, \mathcal{T}) is said to be a **topological group** if the mappings

$$\begin{aligned} (G, \mathcal{T}) &\longrightarrow (G, \mathcal{T}) & \text{and} & & (G, \mathcal{T}) \times (G, \mathcal{T}) &\longrightarrow (G, \mathcal{T}) \\ x &\longrightarrow x^{-1} & & & (x, y) &\longrightarrow x \cdot y \end{aligned}$$

are continuous, where x and y are any elements of the group G , and $x \cdot y$ denotes the product in G of x and y . Show that

- (i) \mathbb{R} , with the group operation being addition, is a topological group.
- (ii) Let \mathbb{T} be the subset of the complex plane consisting of those complex numbers of modulus one. If the complex plane is identified with \mathbb{R}^2 (and given the usual topology), then \mathbb{T} with the subspace topology and the group operation being complex multiplication, is a topological group. [This topological group is called the **circle group**.]
- (iii) Let (G, \mathcal{T}) be any topological group, U a subset of G and g any element of G . Then $g \in U \in \mathcal{T}$ if and only if $e \in g^{-1} \cdot U \in \mathcal{T}$, where e denotes the identity element of G .
- (iv) Let (G, \mathcal{T}) be any topological group and U any open set containing the identity element e . Then there exists an open set V containing e such that

$$\{v_1 \cdot v_2 : v_1 \in V \text{ and } v_2 \in V\} \subseteq U.$$

(v)* Any topological group (G, \mathcal{T}) which is a T_1 -space is also a Hausdorff space.

6. A topological space (X, \mathcal{T}) is said to be **locally connected** if it has a basis B consisting of connected (open) sets.
- (i) Verify that \mathbb{Z} is a locally connected space which is not connected.
 - (ii) Show that \mathbb{R}^n and \mathbb{S}^n are locally connected, for all $n \geq 1$.
 - (iii) Let (X, \mathcal{T}) be the subspace of \mathbb{R}^2 consisting of the points in the line segments joining $\langle 0, 1 \rangle$ to $\langle 0, 0 \rangle$ and to all the points $\langle \frac{1}{n}, 0 \rangle$, $n = 1, 2, 3, \dots$. Show that (X, \mathcal{T}) is connected but not locally connected.
 - (iv) Prove that every open subset of a locally connected space is locally connected.
 - (v) Let $(X_1, \mathcal{T}_1), (X_2, \mathcal{T}_2), \dots, (X_n, \mathcal{T}_n)$ be topological spaces. Prove that $\prod_{i=1}^n (X_i, \mathcal{T}_i)$ is locally connected if and only if each (X_i, \mathcal{T}_i) is locally connected.

8.5 Fundamental Theorem of Algebra

In this section we give an application of topology to another branch of mathematics. We show how to use compactness and the Generalized Heine-Borel Theorem to prove the Fundamental Theorem of Algebra.

8.5.1 Theorem. (The Fundamental Theorem of Algebra) Every polynomial $f(z) = a_n z^n + a_{n-1} z^{n-1} + \cdots + a_1 z + a_0$, where each a_i is a complex number, $a_n \neq 0$, and $n \geq 1$, has a root; that is, there exists a complex number z_0 s.t. $f(z_0) = 0$.

Proof.

$$\begin{aligned}
 |f(z)| &= |a_n z^n + a_{n-1} z^{n-1} + \cdots + a_0| \\
 &\geq |a_n| |z|^n - |z|^{n-1} \left[|a_{n-1}| + \frac{|a_{n-2}|}{|z|} + \cdots + \frac{|a_0|}{|z|^{n-1}} \right] \\
 &\geq |a_n| |z|^n - |z|^{n-1} [|a_{n-1}| + |a_{n-2}| + \cdots + |a_0|], \quad \text{for } |z| \geq 1 \\
 &= |z|^{n-1} [|a_n| |z| - R], \quad \text{for } |z| \geq 1 \text{ and } R = |a_{n-1}| + \cdots + |a_0| \\
 &\geq |z|^{n-1}, \quad \text{for } |z| \geq \max \left\{ 1, \frac{R+1}{|a_n|} \right\}. \tag{1}
 \end{aligned}$$

If we put $p_0 = |f(0)| = |a_0|$ then, by inequality (1), there exists a $T > 0$ such that

$$|f(z)| > p_0, \quad \text{for all } |z| > T \tag{2}$$

Consider the set $D = \{z : z \in \text{complex plane and } |z| \leq T\}$. This is a closed bounded subset of the complex plane $\mathbb{C} = \mathbb{R}^2$ and so, by the Generalized Heine-Borel Theorem, is compact. Therefore, by Proposition 7.2.14, the continuous function $|f| : D \rightarrow \mathbb{R}$ has a least value at some point z_0 . So

$$|f(z_0)| \leq |f(z)|, \quad \text{for all } z \in D.$$

By (2), for all $z \notin D$, $|f(z)| > p_0 = |f(0)| \geq |f(z_0)|$. Therefore

$$|f(z_0)| \leq |f(z)|, \quad \text{for all } z \in \mathbb{C} \tag{3}$$

So we are required to prove that $f(z_0) = 0$. To do this it is convenient to perform a 'translation'. Put $P(z) = f(z + z_0)$. Then, by (2),

$$|P(0)| \leq |P(z)|, \quad \text{for all } z \in \mathbb{C} \tag{4}$$

The problem of showing that $f(z_0) = 0$ is now converted to the equivalent one of proving that $P(0) = 0$.

Now $P(z) = b_n z^n + b_{n-1} z^{n-1} \cdots + b_0$, $b_i \in \mathbb{C}$. So $P(0) = b_0$. We shall show that $b_0 = 0$.

Suppose $b_0 \neq 0$. Then

$$P(z) = b_0 + b_k z^k + z^{k+1} Q(z), \quad (5)$$

where $Q(z)$ is a polynomial and b_k is the smallest $b_i \neq 0$, $i > 0$.

e.g. if $P(z) = 10z^7 + 6z^5 + 3z^4 + 4z^3 + 2z^2 + 1$, then $b_0 = 1$, $b_k = 2$, ($b_1 = 0$), and

$$P(z) = 1 + 2z^2 + z^3 \overbrace{(4 + 3z + 6z^2 + 10z^4)}^{Q(z)}.$$

Let $w \in \mathbb{C}$ be a k^{th} root of the number $-b_0/b_k$; that is, $w^k = -b_0/b_k$.

As $Q(z)$ is a polynomial, for t a real number,

$$t |Q(tw)| \rightarrow 0, \quad \text{as } t \rightarrow 0$$

This implies that $t |w^{k+1} Q(tw)| \rightarrow 0$ as $t \rightarrow 0$.

So there exists a real number t_0 with $0 < t_0 < 1$ such that

$$t_0 |w^{k+1} Q(t_0 w)| < |b_0| \quad (6)$$

$$\begin{aligned} \text{So, by (5), } P(t_0 w) &= b_0 + b_k (t_0 w)^k + (t_0 w)^{k+1} Q(t_0 w) \\ &= b_0 + b_k \left[t_0^k \left(\frac{-b_0}{b_k} \right) \right] + (t_0 w)^{k+1} Q(t_0 w) \\ &= b_0 (1 - t_0^k) + (t_0 w)^{k+1} Q(t_0 w) \end{aligned}$$

$$\begin{aligned} \text{Therefore } |P(t_0 w)| &\leq (1 - t_0^k) |b_0| + t_0^{k+1} |w^{k+1} Q(t_0 w)| \\ &< (1 - t_0^k) |b_0| + t_0^k |b_0|, \quad \text{by (6)} \\ &= |b_0| \\ &= |P(0)| \end{aligned} \quad (7)$$

But (7) contradicts (4). Therefore the supposition that $b_0 \neq 0$ is false; that is, $P(0) = 0$, as required. \square

8.6 Postscript

As mentioned in the Introduction, this is one of three chapters devoted to product spaces. The easiest case is that of finite products. In the next chapter we study countably infinite products and in Chapter 10, the general case. The most important result proved in this section is Tychonoff's Theorem¹. In Chapter 10 this is generalized to arbitrary sized products.

The second result we called a theorem here is the Generalized Heine-Borel Theorem which characterizes the compact subsets of \mathbb{R}^n as those which are closed and bounded.

Exercises 8.4 #5 introduced the notion of topological group, that is a set with the structure of both a topological space and a group, and with the two structures related in an appropriate manner. Topological group theory is a rich and interesting branch of mathematics. Exercises 8.3 #1 introduced the notion of locally compact topological space. Such spaces play a central role in topological group theory.

Our study of connectedness has been furthered in this section by defining the component of a point. This allows us to partition any topological space into connected sets. In a connected space like \mathbb{R}^n the component of any point is the whole space. At the other end of the scale, the components in any totally disconnected space, for example, \mathbb{Q} , are all singleton sets.

As mentioned above, compactness has a local version. So too does connectedness. Exercises 8.4 #6 defined locally connected. However, while every compact space is locally compact, not every connected space is locally connected. Indeed many properties \mathcal{P} have local versions called **locally \mathcal{P}** , and \mathcal{P} usually does not imply locally \mathcal{P} and locally \mathcal{P} usually does not imply \mathcal{P} .

At the end of the chapter we gave a topological proof of the Fundamental Theorem of Algebra. The fact that a theorem in one branch of mathematics can be proved using methods from another branch is but one indication of why mathematics should not be compartmentalized. While you may have separate courses on algebra, complex analysis, and number theory these topics are, in fact, interrelated.

For those who know some category theory, we observe that the category of topological spaces and continuous mappings has both products and coproducts. The products in the category are indeed the products of the topological spaces. You may care to identify the coproducts.

¹You should have noticed how sparingly we use the word "theorem", so when we do use that term it is because the result is important.

Appendix 1: Infinite Sets

Introduction

Once upon a time in a far-off land there were two hotels, the Hotel Finite (an ordinary hotel with a finite number of rooms) and Hilbert's Hotel Infinite (an extra-ordinary hotel with an infinite number of rooms numbered $1, 2, \dots, n, \dots$). One day a visitor arrived in town seeking a room. She went first to the Hotel Finite and was informed that all rooms were occupied and so she could not be accommodated, but she was told that the other hotel, Hilbert's Hotel Infinite, can always find an extra room. So she went to Hilbert's Hotel Infinite and was told that there too all rooms were occupied. However, the desk clerk said at this hotel an extra guest can always be accommodated without evicting anyone. He moved the guest from room 1 to room 2, the guest from room 2 to room 3, and so on. Room 1 then became vacant!

From this cute example we see that there is an intrinsic difference between infinite sets and finite sets. The aim of this Appendix is to provide a gentle but very brief introduction to the theory of Infinite Sets. This is a fascinating topic which, if you have not studied it before, will contain several surprises. We shall learn that "infinite sets were not created equal" - some are bigger than others. At first pass it is not at all clear what this statement could possibly mean. We will need to define the term "bigger". Indeed we will need to define what we mean by "two sets are the same size".

A1.1 Countable Sets

A1.1.1 Definitions. Let A and B be sets. Then A is said to be **equipotent** to B , denoted by $A \sim B$, if there exists a function $f : A \rightarrow B$ which is both one-to-one and onto (that is, f is a **bijection** or a **one-to-one correspondence**).

A1.1.2 Proposition. Let A , B , and C be sets.

- (i) Then $A \sim A$.
- (ii) If $A \sim B$ then $B \sim A$.
- (iii) If $A \sim B$ and $B \sim C$ then $A \sim C$.

Outline Proof.

- (i) The identity function f on A , given by $f(x) = x$, for all $x \in A$, is a one-to-one correspondence between A and itself.
- (ii) If f is a bijection of A onto B then it has an inverse function g from B to A and g is also a one-to-one correspondence.
- (iii) If $f : A \rightarrow B$ is a one-to-one correspondence and $g : B \rightarrow C$ is a one-to-one correspondence, then their composition $gf : A \rightarrow C$ is also a one-to-one correspondence. \square

Proposition A1.1.2 says that the relation “ \sim ” is reflexive (i), symmetric (ii), and transitive (iii); that is, “ \sim ” is an **equivalence relation**.

A1.1.3 Proposition. Let $n, m \in \mathbb{N}$. Then the sets $\{1, 2, \dots, n\}$ and $\{1, 2, \dots, m\}$ are equipotent if and only if $n = m$.

Proof. Exercise. \square

Now we explicitly define the terms “finite set” and “infinite set”.

A1.1.4 Definitions. Let S be a set.

- (i) Then S is said to be **finite** if it is the empty set, \emptyset , or it is equipotent to $\{1, 2, \dots, n\}$, for some $n \in \mathbb{N}$.
- (ii) If S is not finite, then it is said to be **infinite**.
- (iii) If $S \sim \{1, 2, \dots, n\}$ then S is said to have **cardinality** n , which is denoted by **card** $S = n$.
- (iv) If $S = \emptyset$ then the cardinality is said to be 0, which is denoted by **card** $\emptyset = 0$.

The next step is to define the “smallest” kind of infinite set. Such sets will be called countably infinite. At this stage we do not know that there is any “bigger” kind of infinite set – indeed we do not even know what “bigger” would mean in this context.

A1.1.5 Definitions. Let S be a set.

- (i) The set S is said to be **countably infinite** (or **denumerable**) if it is equipotent to \mathbb{N} .
- (ii) The set S is said to be **countable** if it is finite or countably infinite.
- (iii) If S is countably infinite then it is said to have **cardinality** \aleph_0 , denoted by **card** $S = \aleph_0$.
- (iv) A set S is said to be **uncountable** if it is not countable.

A1.1.6 Remark. We see that if the set S is countably infinite, then $S = \{s_1, s_2, \dots, s_n, \dots\}$ where $f : \mathbb{N} \rightarrow S$ is a one-to-one correspondence and $s_n = f(n)$, for all $n \in \mathbb{N}$. So we can **list** the elements of S . Of course if S is finite and non-empty, we can also list its elements by $S = \{s_1, s_2, \dots, s_n\}$. So we can list the elements of any countable set. Conversely, **if the elements of S can be listed then S is countable** as the listing defines a one-to-one correspondence with \mathbb{N} or $\{1, 2, \dots, n\}$. □

A1.1.7 Example. The set S of all even positive integers is countably infinite.

Proof. The function $f : \mathbb{N} \rightarrow S$ given by $f(n) = 2n$, for all $n \in \mathbb{N}$, is a one-to-one correspondence. □

Example A1.1.7 is worthy of a little contemplation. We think of two sets being in one-to-one correspondence if they are “the same size”. But here we have the set \mathbb{N} in one-to-one correspondence with one of its proper subsets. This does not happen with finite sets. Indeed finite sets can be characterized as those sets which are not equipotent to any of their proper subsets.

A1.1.8 Example. The set \mathbb{Z} of all integers is countably infinite.

Proof. The function $f : \mathbb{N} \rightarrow \mathbb{Z}$ given by

$$f(n) = \begin{cases} m, & \text{if } n = 2m, m \geq 1 \\ -m, & \text{if } n = 2m + 1, m \geq 1 \\ 0, & \text{if } n = 1. \end{cases}$$

is a one-to-one correspondence. □

A1.1.9 Example. The set S of all positive integers which are perfect squares is countably infinite.

Proof. The function $f : \mathbb{N} \rightarrow S$ given by $f(n) = n^2$ is a one-to-one correspondence. □

Example A1.1.9 was proved by G. Galileo about 1600. It troubled him and suggested to him that the infinite is not man’s domain.

A1.1.10 Proposition. If a set S is equipotent to a countable set then it is countable.

Proof. Exercise. □

A1.1.11 Proposition. If S is a countable set and $T \subset S$ then T is countable.

Proof. Since S is countable we can write it as a list $S = \{s_1, s_2, \dots\}$ (a finite list if S is finite, an infinite one if S is countably infinite).

Let t_1 be the first s_i in T (if $T \neq \emptyset$). Let t_2 be the second s_i in T (if $T \neq \{t_1\}$). Let t_3 be the third s_i in T (if $T \neq \{t_1, t_2\}$), \dots

This process comes to an end only if $T = \{t_1, t_2, \dots, t_n\}$ for some n , in which case T is finite. If the process does not come to an end we obtain a list $\{t_1, t_2, \dots, t_n, \dots\}$ of members of T . This list contains every member of T , because if $s_i \in T$ then we reach s_i no later than the i^{th} step in the process; so s_i occurs in the list. Hence T is countably infinite. So T is either finite or countably infinite. \square

As an immediate consequence of Proposition 1.1.11 and Example 1.1.8 we have the following result.

A1.1.12 Corollary. Every subset of \mathbb{Z} is countable. \square

A1.1.13 Lemma. If $S_1, S_2, \dots, S_n, \dots$ is a countably infinite family of countably infinite sets such that $S_i \cap S_j = \emptyset$ for $i \neq j$, then $\bigcup_{i=1}^{\infty} S_i$ is a countably infinite set.

Proof. As each S_i is a countably infinite set, $S_i = \{s_{i1}, s_{i2}, \dots, s_{in}, \dots\}$. Now put the s_{ij} in a square array and list them by zigzagging up and down the short diagonals.

$$\begin{array}{ccccccc}
 s_{11} & \rightarrow & s_{12} & & s_{13} & \rightarrow & s_{14} & \cdots \\
 & & \swarrow & & \nearrow & & \swarrow & \\
 s_{21} & & s_{22} & & s_{23} & & \cdots & \\
 & & \downarrow & \nearrow & & \swarrow & \nearrow & \\
 s_{31} & & s_{32} & & s_{33} & & \cdots & \\
 \vdots & \swarrow & \vdots & \nearrow & \vdots & & \ddots &
 \end{array}$$

This shows that all members of $\bigcup_{i=1}^{\infty} S_i$ are listed, and the list is infinite because each S_i is infinite. So $\bigcup_{i=1}^{\infty} S_i$ is countably infinite. \square

In Lemma A1.1.13 we assumed that the sets S_i were pairwise disjoint. If they are not pairwise disjoint the proof is easily modified by deleting repeated elements to obtain:

A1.1.14 Lemma. If $S_1, S_2, \dots, S_n, \dots$ is a countably infinite family of countably infinite sets, then $\bigcup_{i=1}^{\infty} S_i$ is a countably infinite set. \square

A1.1.15 Proposition. The union of any countable family of countable sets is countable.

Proof. Exercise. \square

A1.1.16 Proposition. If S and T are countably infinite sets then the product set $S \times T = \{\langle s, t \rangle : s \in S, t \in T\}$ is a countably infinite set.

Proof. Let $S = \{s_1, s_2, \dots, s_n, \dots\}$ and $T = \{t_1, t_2, \dots, t_n, \dots\}$. Then

$$S \times T = \bigcup_{i=1}^{\infty} \{\langle s_i, t_1 \rangle, \langle s_i, t_2 \rangle, \dots, \langle s_i, t_n \rangle, \dots\}.$$

So $S \times T$ is a countably infinite union of countably infinite sets and is therefore countably infinite. \square

A1.1.17 Corollary. Every finite product of countable sets is countable. \square

We are now ready for a significant application of our observations on countable sets.

A1.1.18 Lemma. The set, $\mathbb{Q}^{>0}$, of all positive rational numbers is countably infinite.

Proof. Let S_i be the set of all positive rational numbers with denominator i , for $i \in \mathbb{N}$. Then $S_i = \{\frac{1}{i}, \frac{2}{i}, \dots, \frac{n}{i}, \dots\}$ and $\mathbb{Q}^{>0} = \bigcup_{i=1}^{\infty} S_i$. As each S_i is countably infinite, Proposition A1.1.15 yields that $\mathbb{Q}^{>0}$ is countably infinite. \square

We are now ready to prove that the set, \mathbb{Q} , of all rational numbers is countably infinite; that is, there exists a one-to-one correspondence between the set \mathbb{Q} and the (seemingly) very much smaller set, \mathbb{N} , of all positive integers.

A1.1.19 Theorem. The set \mathbb{Q} of all rational numbers is countably infinite.

Proof. Clearly the set $\mathbb{Q}^{<0}$ of all negative rational numbers is equipotent to the set, $\mathbb{Q}^{>0}$, of all positive rational numbers and so using Proposition A1.1.10 and Lemma A1.1.18 we obtain that $\mathbb{Q}^{<0}$ is countably infinite.

Finally observe that \mathbb{Q} is the union of the three sets $\mathbb{Q}^{>0}$, $\mathbb{Q}^{<0}$ and $\{0\}$ and so it too is countably infinite by Proposition A1.1.15. \square

A1.1.20 Corollary. Every set of rational numbers is countable.

Proof. This is a consequence of Theorem A1.1.19 and Proposition A1.1.11. \square

A1.1.21 Definitions. A real number x is said to be an **algebraic number** if there is a natural number n and integers a_0, a_1, \dots, a_n with $a_0 \neq 0$ such that

$$a_0x^n + a_1x^{n-1} + \dots + a_{n-1}x + a_n = 0.$$

A real number which is not an algebraic number is said to be a **transcendental number**.

A1.1.22 Example. Every rational number is an algebraic number.

Proof. If $x = \frac{p}{q}$, for $p, q \in \mathbb{Z}$ and $q \neq 0$, then $qx - p = 0$; that is, x is an algebraic number with $n = 1$, $a_0 = q$, and $a_n = -p$. \square

A1.1.23 Example. The number $\sqrt{2}$ is an algebraic number which is not a rational number.

Proof. While $x = \sqrt{2}$ is irrational, it satisfies $x^2 - 2 = 0$ and so is algebraic. \square

A1.1.24 Remark. It is also easily verified that $\sqrt[4]{5} - \sqrt{3}$ is an algebraic number since it satisfies $x^8 - 12x^6 + 44x^4 - 288x^2 + 16 = 0$. Indeed any real number which can be constructed from the set of integers using only a finite number of the operations of addition, subtraction, multiplication, division and the extraction of square roots, cube roots, \dots , is algebraic. \square

A1.1.25 Remark. Remark A1.1.24 shows that “most” numbers we think of are algebraic numbers. To show that a given number is transcendental can be extremely difficult. The first such demonstration was in 1844 when Liouville proved the transcendence of the number

$$\sum_{n=1}^{\infty} \frac{1}{10^{n!}} = 0.110001000000000000000000100\dots$$

It was Charles Hermite who, in 1873, showed that e is transcendental. In 1882 Lindemann proved that the number π is transcendental thereby answering in the negative the 2,000 year old question about squaring the circle. (The question is: given a circle of radius 1, is it possible, using only a straight edge and compass, to construct a square with the same area? A full exposition of this problem and proofs that e and π are transcendental are to be found in the book, Jones, Morris & Pearson [112].) \square

We now proceed to prove that the set \mathcal{A} of all algebraic numbers is also countably infinite. This is a more powerful result than Theorem A1.1.19 which is in fact a corollary of this result.

A1.1.26 Theorem. The set \mathcal{A} of all algebraic numbers is countably infinite.

Proof. Consider the polynomial $f(x) = a_0x^n + a_1x^{n-1} + \cdots + a_{n-1}x + a_n$, where $a_0 \neq 0$ and each $a_i \in \mathbb{Z}$ and define its **height** to be $k = n + |a_0| + |a_1| + \cdots + |a_n|$.

For each positive integer k , let A_k be the set of all roots of all such polynomials of height k . Clearly $\mathcal{A} = \bigcup_{k=1}^{\infty} A_k$.

Therefore, to show that \mathcal{A} is countably infinite, it suffices by Proposition A1.1.15 to show that each A_k is finite.

If f is a polynomial of degree n , then clearly $n \leq k$ and $|a_i| \leq k$ for $i = 1, 2, \dots, n$. So the set of all polynomials of height k is certainly finite.

Further, a polynomial of degree n has at most n roots. Consequently each polynomial of height k has no more than k roots. Hence the set A_k is finite, as required. \square

A1.1.27 Corollary. Every set of algebraic numbers is countable. \square

Note that Corollary A1.1.27 has as a special case, Corollary A1.1.20.

So far we have not produced any example of an uncountable set. Before doing so we observe that certain mappings will not take us out of the collection of countable sets.

A1.1.28 Proposition. Let X and Y be sets and f a map of X into Y .

- (i) If X is countable and f is surjective (that is, an onto mapping), then Y is countable.
- (ii) If Y is countable and f is injective (that is, a one-to-one mapping), then X is countable.

Proof. Exercise. \square

A1.1.29 Proposition. Let S be a countable set. Then the set of all finite subsets of S is also countable.

Proof. Exercise. \square

A1.1.30 Definition. Let S be any set. The set of all subsets of S is said to be the **power set** of S and is denoted by $\mathcal{P}(S)$.

A1.1.31 Theorem. (Georg Cantor) For every set S , the power set, $\mathcal{P}(S)$, is not equipotent to S ; that is, $\mathcal{P}(S) \not\sim S$.

Proof. We have to prove that there is no one-to-one correspondence between S and $\mathcal{P}(S)$. We shall prove more: that there is not even any surjective function mapping S onto $\mathcal{P}(S)$.

Suppose that there exists a function $f: S \rightarrow \mathcal{P}(S)$ which is onto. For each $x \in S$, $f(x) \in \mathcal{P}(S)$, which is the same as saying that $f(x) \subseteq S$.

Let $T = \{x : x \in S \text{ and } x \notin f(x)\}$. Then $T \subseteq S$; that is, $T \in \mathcal{P}(S)$. So $T = f(y)$ for some $y \in S$, since f maps S onto $\mathcal{P}(S)$. Now $y \in T$ or $y \notin T$.

Case 1.

$$\begin{aligned} y \in T &\Rightarrow y \notin f(y) \quad (\text{by the definition of } T) \\ &\Rightarrow y \notin T \quad (\text{since } f(y) = T). \end{aligned}$$

So Case 1 is impossible.

Case 2.

$$\begin{aligned} y \notin T &\Rightarrow y \in f(y) \quad (\text{by the definition of } T) \\ &\Rightarrow y \in T \quad (\text{since } f(y) = T). \end{aligned}$$

So Case 2 is impossible.

As both cases are impossible, we have a contradiction. So our supposition is false and there does not exist any function mapping S onto $\mathcal{P}(S)$. Thus $\mathcal{P}(S)$ is not equipotent to S . \square

A1.1.32 Lemma. If S is any set, then S is equipotent to a subset of its power set, $\mathcal{P}(S)$.

Proof. Define the mapping $f: S \rightarrow \mathcal{P}(S)$ by $f(x) = \{x\}$, for each $x \in S$. Clearly f is a one-to-one correspondence between the sets S and $f(S)$. So S is equipotent to the subset $f(S)$ of $\mathcal{P}(S)$. \square

A1.1.33 Proposition. If S is any infinite set, then $\mathcal{P}(S)$ is an uncountable set.

Proof. As S is infinite, the set $\mathcal{P}(S)$ is infinite. By Theorem A1.1.31, $\mathcal{P}(S)$ is not equipotent to S .

Suppose $\mathcal{P}(S)$ is countably infinite. Then by Proposition A1.1.11, Lemma 1.1.32 and Proposition A1.1.10, S is countably infinite. So S and $\mathcal{P}(S)$ are equipotent, which is a contradiction. Hence $\mathcal{P}(S)$ is uncountable. \square

Proposition A1.1.33 demonstrates the existence of uncountable sets. However the sceptic may feel that the example is contrived. So we conclude this section by observing that important and familiar sets are uncountable.

A1.1.34 Lemma. The set of all real numbers in the half open interval $[1, 2)$ is not countable.

Proof. (Cantor's diagonal argument) We shall show that the set of all real numbers in $[1, 2)$ cannot be listed.

Let $L = \{r_1, r_2, \dots, r_n, \dots\}$ be any list of real numbers each of which lies in the set $[1, 2)$. Write down their decimal expansions:

$$\begin{aligned} r_1 &= 1.r_{11}r_{12} \dots r_{1n} \dots \\ r_2 &= 1.r_{21}r_{22} \dots r_{2n} \dots \\ &\vdots \\ r_m &= 1.r_{m1}r_{m2} \dots r_{mn} \dots \\ &\vdots \end{aligned}$$

Consider the real number a defined to be $1.a_1a_2 \dots a_n \dots$ where, for each $n \in \mathbb{N}$,

$$a_n = \begin{cases} 1 & \text{if } r_{nn} \neq 1 \\ 2 & \text{if } r_{nn} = 1. \end{cases}$$

Clearly $a_n \neq r_{nn}$ and so $a \neq r_n$, for all $n \in \mathbb{N}$. Thus a does not appear anywhere in the list L . Thus there does not exist a listing of the set of all real numbers in $[1, 2)$; that is, this set is uncountable. \square

A1.1.35 Theorem. The set, \mathbb{R} , of all real numbers is uncountable.

Proof. Suppose \mathbb{R} is countable. Then by Proposition A1.1.11 the set of all real numbers in $[1, 2)$ is countable, which contradicts Lemma A1.1.34. Therefore \mathbb{R} is uncountable. \square

A1.1.36 Corollary. The set, \mathbb{I} , of all irrational numbers is uncountable.

Proof. Suppose \mathbb{I} is countable. Then \mathbb{R} is the union of two countable sets: \mathbb{I} and \mathbb{Q} . By Proposition A1.1.15, \mathbb{R} is countable which is a contradiction. Hence \mathbb{I} is uncountable. \square

Using a similar proof to that in Corollary A1.1.36 we obtain the following result.

A1.1.37 Corollary. The set of all transcendental numbers is uncountable. \square

A1.2 Cardinal Numbers

In the previous section we defined countably infinite and uncountable and suggested, without explaining what it might mean, that uncountable sets are “bigger” than countably infinite sets. To explain what we mean by “bigger” we will need the next theorem.

Our exposition is based on that in the book, Halmos [84]

A1.2.1 Theorem. (Cantor-Schröder-Bernstein) Let S and T be sets. If S is equipotent to a subset of T and T is equipotent to a subset of S , then S is equipotent to T .

Proof. Without loss of generality we can assume S and T are disjoint. Let $f : S \rightarrow T$ and $g : T \rightarrow S$ be one-to-one maps. We are required to find a bijection of S onto T .

We say that an element s is a **parent** of an element $f(s)$ and $f(s)$ is a **descendant** of s . Also t is a parent of $g(t)$ and $g(t)$ is a descendant of t . Each $s \in S$ has an infinite sequence of descendants: $f(s), g(f(s)), f(g(f(s)))$, and so on. We say that each term in such a sequence is an **ancestor** of all the terms that follow it in the sequence.

Now let $s \in S$. If we trace its ancestry back as far as possible one of three things must happen:

- (i) the list of ancestors is finite, and stops at an element of S which has no ancestor;
- (ii) the list of ancestors is finite, and stops at an element of T which has no ancestor;
- (iii) the list of ancestors is infinite.

Let S_S be the set of those elements in S which originate in S ; that is, S_S is the set $S \setminus g(T)$ plus all of its descendants in S . Let S_T be the set of those elements which originate in T ; that is, S_T is the set of descendants in S of $T \setminus f(S)$. Let S_∞ be the set of all elements in S with no parentless ancestors. Then S is the union of the three disjoint sets S_S, S_T and S_∞ . Similarly T is the disjoint union of the three similarly defined sets: T_T, T_S , and T_∞ .

Clearly the restriction of f to S_S is a bijection of S_S onto T_S .

Now let g^{-1} be the inverse function of the bijection g of T onto $g(T)$. Clearly the restriction of g^{-1} to S_T is a bijection of S_T onto T_T .

Finally, the restriction of f to S_∞ is a bijection of S_∞ onto T_∞ .

Define $h : S \rightarrow T$ by

$$h(s) = \begin{cases} f(s) & \text{if } s \in S_S \\ g^{-1}(s) & \text{if } s \in S_T \\ f(s) & \text{if } s \in S_\infty. \end{cases}$$

Then h is a bijection of S onto T . So S is equipotent to T . □

Our next task is to define what we mean by “cardinal number”.

A1.2.2 Definitions. A collection, \aleph , of sets is said to be a **cardinal number** if it satisfies the conditions:

- (i) Let S and T be sets. If S and T are in \aleph , then $S \sim T$;
- (ii) Let A and B be sets. If A is in \aleph and $B \sim A$, then B is in \aleph .

If \aleph is a cardinal number and A is a set in \aleph , then we write **card** $A = \aleph$.

Definitions A1.2.2 may, at first sight, seem strange. A cardinal number is defined as a collection of sets. So let us look at a couple of special cases:

If a set A has two elements we write $\text{card } A = 2$; the cardinal number 2 is the collection of all sets equipotent to the set $\{1, 2\}$, that is the collection of all sets with 2 elements.

If a set S is countable infinite, then we write $\text{card } S = \aleph_0$; in this case the cardinal number \aleph_0 is the collection of all sets equipotent to \mathbb{N} .

Let S and T be sets. Then S is equipotent to T if and only if $\text{card } S = \text{card } T$.

A1.2.3 Definitions. The cardinality of \mathbb{R} is denoted by **c**; that is, $\text{card } \mathbb{R} = \mathfrak{c}$. The cardinality of \mathbb{N} is denoted by \aleph_0 .

The symbol \mathfrak{c} is used in Definitions A1.2.3 as we think of \mathbb{R} as the “continuum”.

We now define an ordering of the cardinal numbers.

A1.2.4 Definitions. Let m and n be cardinal numbers. Then the cardinal m is said to be less than or equal to n , that is $m \leq n$, if there are sets S and T such that $\text{card } m = S$, $\text{card } T = n$, and S is equipotent to a subset of T . Further, the cardinal m is said to be strictly less than n , that is $m < n$, if $m \leq n$ and $m \neq n$.

As \mathbb{R} has \mathbb{N} as a subset, $\text{card } \mathbb{R} = \mathfrak{c}$ and $\text{card } \mathbb{N} = \aleph_0$, and \mathbb{R} is not equipotent to \mathbb{N} , we immediately deduce the following result.

A1.2.5 Proposition. $\aleph_0 < \mathfrak{c}$. □

We also know that for any set S , S is equipotent to a subset of $\mathcal{P}(S)$, and S is not equipotent to $\mathcal{P}(S)$, from which we deduce the next result.

A1.2.6 Theorem. For any set S , $\text{card } S < \text{card } \mathcal{P}(S)$. □

The following is a restatement of the Cantor-Schröder-Bernstein Theorem.

A1.2.7 Theorem. Let m and n be cardinal numbers. If $m \leq n$ and $n \leq m$, then $m = n$. □

A1.2.8 Remark. We observe that [there are an infinite number of infinite cardinal numbers](#). This is clear from the fact that:

$$(*) \quad \aleph_0 = \text{card } \mathbb{N} < \text{card } \mathcal{P}(\mathbb{N}) < \text{card } \mathcal{P}(\mathcal{P}(\mathbb{N})) < \dots \quad \square$$

The next result is an immediate consequence of Theorem A1.2.6.

A1.2.9 Corollary. There is no largest cardinal number. □

Noting that if a finite set S has n elements, then its power set $\mathcal{P}(S)$ has 2^n elements, it is natural to introduce the following notation.

A1.2.10 Definition. If a set S has cardinality \aleph , then the cardinality of $\mathcal{P}(S)$ is denoted by 2^\aleph .

Thus we can rewrite $(*)$ above as:

$$(**) \quad \aleph_0 < 2^{\aleph_0} < 2^{2^{\aleph_0}} < 2^{2^{2^{\aleph_0}}} < \dots$$

When we look at this sequence of cardinal numbers there are a number of questions which should come to mind including:

- (1) Is \aleph_0 the smallest infinite cardinal number?

- (2) Is \aleph_0 equal to one of the cardinal numbers on this list?
 (3) Are there any cardinal numbers strictly between \aleph_0 and 2^{\aleph_0} ?

These questions, especially (1) and (3), are not easily answered. Indeed they require a careful look at the axioms of set theory. It is not possible in this Appendix to discuss seriously the axioms of set theory. Nevertheless we will touch upon the above questions later in the appendix.

We conclude this section by identifying the cardinalities of a few more familiar sets.

A1.2.11 Lemma. Let a and b be real numbers with $a < b$. Then

- (i) $[0, 1] \sim [a, b]$;
- (ii) $(0, 1) \sim (a, b)$;
- (iii) $(0, 1) \sim (1, \infty)$;
- (iv) $(-\infty, -1) \sim (-2, -1)$;
- (v) $(1, \infty) \sim (1, 2)$;
- (vi) $\mathbb{R} \sim (-2, 2)$;
- (vii) $\mathbb{R} \sim (a, b)$.

Outline Proof. (i) is proved by observing that $f(x) = a + bx$ defines a one-to-one function of $[0, 1]$ onto $[a, b]$. (ii) and (iii) are similarly proved by finding suitable functions. (iv) is proved using (iii) and (ii). (v) follows from (iv). (vi) follows from (iv) and (v) by observing that \mathbb{R} is the union of the pairwise disjoint sets $(-\infty, -1)$, $[-1, 1]$ and $(1, \infty)$. (vii) follows from (vi) and (ii). \square .

A1.2.12 Proposition. Let a and b be real numbers with $a < b$. If S is any subset of \mathbb{R} such that $(a, b) \subseteq S$, then $\text{card } S = \mathfrak{c}$. In particular, $\text{card } (a, b) = \text{card } [a, b] = \mathfrak{c}$.

Proof. Using Lemma A1.2.11 observe that

$$\text{card } \mathbb{R} = \text{card } (a, b) \leq \text{card } [a, b] \leq \text{card } \mathbb{R}.$$

So $\text{card } (a, b) = \text{card } [a, b] = \text{card } \mathbb{R} = \mathfrak{c}$. □

A1.2.13 Proposition. If \mathbb{R}^2 is the set of points in the Euclidean plane, then $\text{card } (\mathbb{R}^2) = \mathfrak{c}$.

Outline Proof. By Proposition A1.2.12, \mathbb{R} is equipotent to the half-open interval $[0, 1)$ and it is easily shown that it suffices to prove that $[0, 1) \times [0, 1) \sim [0, 1)$.

Define $f : [0, 1) \rightarrow [0, 1) \times [0, 1)$ by $f(x)$ is the point $\langle x, 0 \rangle$. Then f is a one-to-one mapping of $[0, 1)$ into $[0, 1) \times [0, 1)$ and so $\mathfrak{c} = \text{card } [0, 1) \leq \text{card } [0, 1) \times [0, 1)$.

By the Cantor-Schröder-Bernstein Theorem, it suffices then to find a one-to-one function g of $[0, 1) \times [0, 1)$ into $[0, 1)$. Define

$$g(\langle 0.a_1a_2 \dots a_n \dots, 0.b_1b_2 \dots b_n \dots \rangle) = 0.a_1b_1a_2b_2 \dots a_nb_n \dots$$

Clearly g is well-defined (as each real number in $[0, 1)$ has a unique decimal representation that does not end in $99 \dots 9 \dots$) and is one-to-one, which completes the proof. □

A1.3 Cardinal Arithmetic

We begin with a definition of addition of cardinal numbers. Of course, when the cardinal numbers are finite, this definition must agree with addition of finite numbers.

A1.3.1 Definition. Let α and β be any cardinal numbers and select disjoint sets A and B such that $\text{card } A = \alpha$ and $\text{card } B = \beta$. Then the **sum of the cardinal numbers α and β** is denoted by $\alpha + \beta$ and is equal to $\text{card } (A \cup B)$.

A1.3.2 Remark. Before knowing that the above definition makes sense and in particular does not depend on the choice of the sets A and B , it is necessary to verify that if A_1 and B_1 are disjoint sets and A and B are disjoint sets such that $\text{card } A = \text{card } A_1$ and $\text{card } B = \text{card } B_1$, then $A \cup B \sim A_1 \cup B_1$; that is, $\text{card}(A \cup B) = \text{card}(A_1 \cup B_1)$. This is a straightforward task and so is left as an exercise. \square

A1.3.3 Proposition. For any cardinal numbers α , β and γ :

- (i) $\alpha + \beta = \beta + \alpha$;
- (ii) $\alpha + (\beta + \gamma) = (\alpha + \beta) + \gamma$;
- (iii) $\alpha + 0 = \alpha$;
- (iv) If $\alpha \leq \beta$ then $\alpha + \gamma \leq \beta + \gamma$.

Proof. Exercise \square

A1.3.4 Proposition.

- (i) $\aleph_0 + \aleph_0 = \aleph_0$;
- (ii) $\mathfrak{c} + \aleph_0 = \mathfrak{c}$;
- (iii) $\mathfrak{c} + \mathfrak{c} = \mathfrak{c}$;
- (iv) For any finite cardinal n , $n + \aleph_0 = \aleph_0$ and $n + \mathfrak{c} = \mathfrak{c}$.

Proof.

- (i) The listing $1, -1, 2, -2, \dots, n, -n, \dots$ shows that the union of the two countably infinite sets \mathbb{N} and the set of negative integers is a countably infinite set.
- (ii) Noting that $[-2, -1] \cup \mathbb{N} \subset \mathbb{R}$, we see that $\text{card}[-2, -1] + \text{card } \mathbb{N} \leq \text{card } \mathbb{R} = \mathfrak{c}$. So $\mathfrak{c} = \text{card}[-2, -1] \leq \text{card}([-2, -1] \cup \mathbb{N}) = \text{card}[-2, -1] + \text{card } \mathbb{N} = \mathfrak{c} + \aleph_0 \leq \mathfrak{c}$.
- (iii) Note that $\mathfrak{c} \leq \mathfrak{c} + \mathfrak{c} = \text{card}((0, 1) \cup (1, 2)) \leq \text{card } \mathbb{R} = \mathfrak{c}$ from which the required result is immediate.
- (iv) Observe that $\aleph_0 \leq n + \aleph_0 \leq \aleph_0 + \aleph_0 = \aleph_0$ and $\mathfrak{c} \leq n + \mathfrak{c} \leq \mathfrak{c} + \mathfrak{c} = \mathfrak{c}$, from which the results follow. \square

Next we define multiplication of cardinal numbers.

A1.3.5 Definition. Let α and β be any cardinal numbers and select disjoint sets A and B such that $\text{card } A = \alpha$ and $\text{card } B = \beta$. Then the **product of the cardinal numbers α and β** is denoted by $\alpha\beta$ and is equal to $\text{card } (A \times B)$.

As in the case of addition of cardinal numbers, it is necessary, but routine, to check in Definition A1.3.5 that $\alpha\beta$ does not depend on the specific choice of the sets A and B .

A1.3.6 Proposition. For any cardinal numbers α, β and γ

- (i) $\alpha\beta = \beta\alpha$;
- (ii) $\alpha(\beta\gamma) = (\alpha\beta)\gamma$;
- (iii) $1\alpha = \alpha$;
- (iv) $0\alpha = 0$;
- (v) $\alpha(\beta + \gamma) = \alpha\beta + \alpha\gamma$;
- (vi) For any finite cardinal n , $n\alpha = \alpha + \alpha + \dots + \alpha$ (n -terms);
- (v1i) If $\alpha \leq \beta$ then $\alpha\gamma \leq \beta\gamma$.

Proof. Exercise □

A1.3.7 Proposition.

- (i) $\aleph_0 \aleph_0 = \aleph_0$;
- (ii) $\mathfrak{c} \mathfrak{c} = \mathfrak{c}$;
- (iii) $\mathfrak{c} \aleph_0 = \mathfrak{c}$;
- (iv) For any finite cardinal n , $n \aleph_0 = \aleph_0$ and $n \mathfrak{c} = \mathfrak{c}$.

Outline Proof. (i) follows from Proposition 1.1.16, while (ii) follows from Proposition A1.2.13. To see (iii), observe that $\mathfrak{c} = \mathfrak{c} \cdot 1 \leq \mathfrak{c} \aleph_0 \leq \mathfrak{c} \mathfrak{c} = \mathfrak{c}$. The proof of (iv) is also straightforward. □

The next step in the arithmetic of cardinal numbers is to define exponentiation of cardinal numbers; that is, if α and β are cardinal numbers then we wish to define α^β .

A1.3.8 Definitions. Let α and β be cardinal numbers and A and B sets such that $\text{card } A = \alpha$ and $\text{card } B = \beta$. The set of all functions f of B into A is denoted by A^B . Further, α^β is defined to be $\text{card } A^B$.

Once again we need to check that the definition makes sense, that is that α^β does not depend on the choice of the sets A and B . We also check that if n and m are finite cardinal numbers, A is a set with n elements and B is a set with m elements, then there are precisely n^m distinct functions from B into A .

We also need to address one more concern: If α is a cardinal number and A is a set such that $\text{card } A = \alpha$, then we have two different definitions of 2^α . The above definition has 2^α as the cardinality of the set of all functions of A into the two point set $\{0, 1\}$. On the other hand, Definition A1.2.10 defines 2^α to be $\text{card } (\mathcal{P}(A))$. It suffices to find a bijection θ of $\{0, 1\}^A$ onto $\mathcal{P}(A)$. Let $f \in \{0, 1\}^A$. Then $f: A \rightarrow \{0, 1\}$. Define $\theta(f) = f^{-1}(1)$. The task of verifying that θ is a bijection is left as an exercise.

A1.3.9 Proposition. For any cardinal numbers α , β and γ :

- (i) $\alpha^{\beta+\gamma} = \alpha^\beta \alpha^\gamma$;
- (ii) $(\alpha\beta)^\gamma = \alpha^\gamma \beta^\gamma$;
- (iii) $(\alpha^\beta)^\gamma = \alpha^{(\beta\gamma)}$;
- (iv) $\alpha \leq \beta$ implies $\alpha^\gamma \leq \beta^\gamma$;
- (v) $\alpha \leq \beta$ implies $\gamma^\alpha \leq \gamma^\beta$.

Proof. Exercise □

After Definition A1.2.10 we asked three questions. We are now in a position to answer the second of these questions.

A1.3.10 Lemma. $\aleph_0^{\aleph_0} = \mathfrak{c}$.

Proof. Observe that $\text{card } \mathbb{N}^{\mathbb{N}} = \aleph_0^{\aleph_0}$ and $\text{card } (0, 1) = \mathfrak{c}$. As the function $f: (0, 1) \rightarrow \mathbb{N}^{\mathbb{N}}$ given by $f(0.a_1a_2 \dots a_n \dots) = \langle a_1, a_2, \dots, a_n, \dots \rangle$ is an injection, it follows that $\mathfrak{c} \leq \aleph_0^{\aleph_0}$.

By the Cantor-Schröder-Bernstein Theorem, to conclude the proof it suffices to find an injective map g of $\mathbb{N}^{\mathbb{N}}$ into $(0, 1)$. If $\langle a_1, a_2, \dots, a_n, \dots \rangle$ is any element of $\mathbb{N}^{\mathbb{N}}$, then each $a_i \in \mathbb{N}$ and so we can write

$a_i = \dots a_{in} a_{i(n-1)} \dots a_{i2} a_{i1}$, where for some $M_i \in \mathbb{N}$, $a_{in} = 0$, for all $n > M_i$ [For example $187 = \dots 00 \dots 0187$ and so if $a_i = 187$ then $a_{i1} = 7$, $a_{i2} = 8$, $a_{i3} = 1$ and $a_{in} = 0$, for $n > M_i = 3$.]

Then define the map g by

$$g(\langle a_1, a_2, \dots, a_n, \dots \rangle) = 0.a_{11}a_{12}a_{21}a_{13}a_{22}a_{31}a_{14}a_{23}a_{32}a_{41}a_{15}a_{24}a_{33}a_{42}a_{51}a_{16} \dots$$

(Compare this with the proof of Lemma A1.1.13.)

Clearly g is an injection, which completes the proof. \square

We now state a beautiful result, first proved by Georg Cantor.

A1.3.11 Theorem. $2^{\aleph_0} = \mathfrak{c}$.

Proof. Firstly observe that $2^{\aleph_0} \leq \aleph_0^{\aleph_0} = \mathfrak{c}$, by Lemma A1.3.10. So we have to verify that $\mathfrak{c} \leq 2^{\aleph_0}$. To do this it suffices to find an injective map f of the set $[0, 1)$ into $\{0, 1\}^{\mathbb{N}}$. Each element x of $[0, 1)$ has a binary representation $x = 0.x_1x_2 \dots x_n \dots$, with each x_i equal to 0 or 1. The binary representation is unique except for representations ending in a string of 1s; for example,

$$1/4 = 0.0100 \dots 0 \dots = 0.0011 \dots 1 \dots$$

Providing that in all such cases we choose the representation with a string of zeros rather than a string of 1s, the representation of numbers in $[0, 1)$ is unique. We define the function $f: [0, 1) \rightarrow \{0, 1\}^{\mathbb{N}}$ which maps $x \in [0, 1)$ to the function $f(x): \mathbb{N} \rightarrow \{0, 1\}$ given by $f(x)(n) = x_n$, $n \in \mathbb{N}$. To see that f is injective, consider any x and y in $[0, 1)$ with $x \neq y$. Then $x_m \neq y_m$, for some $m \in \mathbb{N}$. So $f(x)(m) = x_m \neq y_m = f(y)(m)$. Hence the two functions $f(x): \mathbb{N} \rightarrow \{0, 1\}$ and $f(y): \mathbb{N} \rightarrow \{0, 1\}$ are not equal. As x and y were arbitrary (unequal) elements of $[0, 1)$, it follows that f is indeed injective, as required. \square

A1.3.12 Corollary. If α is a cardinal number such that $2 \leq \alpha \leq \mathfrak{c}$, then $\alpha^{\aleph_0} = \mathfrak{c}$.

Proof. Observe that $\mathfrak{c} = 2^{\aleph_0} \leq \alpha^{\aleph_0} \leq \mathfrak{c}^{\aleph_0} = (2^{\aleph_0})^{\aleph_0} = 2^{\aleph_0 \cdot \aleph_0} = 2^{\aleph_0} = \mathfrak{c}$. □

Bibliography

- [1] *A History of Topology*,
http://www-history.mcs.st-and.ac.uk/histtopics/topology_in_mathematics.html, 2001–.
A history of topology is part of the MacTutor History of Mathematics Archive at the University of St Andrews with links to biographies.
- [2] Colin C. Adams. *The knot book: an elementary introduction to the mathematical theory of knots*. Freeman and Co., New York, 1994.
- [3] J. Frank Adams. *Algebraic topology: a student's guide*. Cambridge University Press, Cambridge, England, 1972.
- [4] G.N. Afanasiev. *Topological effects in quantum mechanics*. Kluwer Academic Publishers, Dordrecht, Boston, 1999.
- [5] M.A. Aguilar, S. Gitler, and C. Prieto. *Algebraic topology from a homotopical viewpoint*. Springer, New York, 2002.
- [6] Paul S. Alexandroff and Heinz Hopf. *Topologie*. Springer-Verlag, Berlin, 1935.
- [7] *Algebraic and Geometric Topology*, <http://www.maths.warwick.ac.uk/agt>, 2001–. a refereed electronic journal.
- [8] Charilaos N. Anziris. *The mystery of knots: computer programming for knot tabulation*. World Scientific Publishers, Singapore; River Edge, N.J., 1999.
- [9] A.V. Arkhangel'skiĭ. *Fundamentals of general topology: problems and exercises*. Kluwer, Boston, 1984.
- [10] A.V. Arkhangel'skiĭ. *Topological function spaces*. Kluwer, Boston, 1992.

- [11] A.V. Arkhangel'skiĭ and L.S. Pontryagin, editors. *General Topology I*. Springer-Verlag, Berlin etc., 1990.
- [12] D.L. Armacost. *The structure of locally compact abelian groups*. M. Dekker, New York, 1981.
- [13] M.A. Armstrong. *Basic topology*. Springer-Verlag, New York, 1983.
- [14] V.I. Arnold and B.A. Khesin. *Topological methods in hydrodynamics*. Springer, New York, 1999.
- [15] Emil Artin. *Introduction to algebraic topology*. C.E. Merrill Publishing Co., Columbus, Ohio, 1969.
- [16] C.E. Aull and R. Lowen, editors. *Handbook of the history of general topology*. Kluwer Academic Publishers, Dordrecht; Boston, 1997.
- [17] Wojciech Banaszczyk. *Additive subgroups of topological vector spaces*. Springer-Verlag, Berlin; New York, 1991.
- [18] Stephen Barr. *Experiments in topology*. Dover Publications, New York, 1989.
- [19] Gerald Alan Beer. *Topologies on closed and convex sets*. Kluwer Academic Publishers, Dordrecht, Boston, 1993.
- [20] Martin P. Bendsoe. *Optimization of structural topology*. Springer, Berlin, New York, 1995.
- [21] Martin P. Bendsoe. *Topology, optimization: theory, methods and applications*. Springer, Berlin, New York, 2003.
- [22] Czeslaw Bessaga and Aleksander Pelczynski. *Selected topics in infinite-dimensional topology*. PWN-Polish Scientific Publishers, Warsaw, 1975.
- [23] Donald W. Blackett. *Elementary topology; a combinatorial and algebraic approach*. Academic Press, New York, 1967.
- [24] Danail Bonchev and Dennis H. Rouvray, editors. *Chemical topology : introduction and fundamental*. Gordon and Breach, Amsterdam, 1999.

- [25] Armand Borel. *Seminars on transformation groups*. Princeton University Press, Princeton, N.J., 1960.
- [26] Karol Borsuk. *Collected Papers/ Karol Borsuk*. PWN-Polish Scientific Publishers, Warsaw, 1983.
- [27] Nicolas Bourbaki. *General topology v.1 & v.2*. Addison-Wesley, Reading, Mass., 1966.
- [28] Nicolas Bourbaki. *Topologie générale, Chap. 1-4 and Chap. 5-10*. Hermann, Paris, 1971 and 1974.
- [29] Nicolas Bourbaki. *Topological vector spaces*. Springer-Verlag, Berlin ; New York, 1987.
- [30] Glen E. Bredon. *Topology and geometry*. Springer, New York, 1997.
- [31] Robert F. Brown. *The Lefschetz fixed point theorem*. Scott, Foresman, Glenview, Ill., 1971.
- [32] Ronald Brown. *Elements of modern topology*. McGraw Hill, New York, 1968.
- [33] Ronald Brown. *Topology : a geometric account of general topology, homotopy types, and the fundamental groupoid*. Halstead Press, New York, 1988.
- [34] Georg Cantor. *Contributions to the founding of the theory of transfinite numbers, by Georg Cantor; tr., and provided with an introduction and notes, by Philip E.B. Jourdain*. The Open Court Publishing Company, Chicago, London, 1915.
- [35] Stephen C. Carlson. *Topology of surfaces, knots, and manifolds: a first undergraduate course*. Wiley, New York, 2001.
- [36] J. Scott Carter. *How surfaces intersect in space : an introduction to topology*. World Scientific Publishers, Singapore ; River Edge, N.J., 1995.
- [37] Eduard Čech. *Topological spaces*. Czechoslovak Academy of Sciences, Prague, 1966.
- [38] Eduard Čech. *Point sets*. Czechoslovak Academy of Sciences, Prague, 1969.
- [39] Graciela Chichilnisky. *Topology and markets*. American Mathematical society, Providence, R.I., 1999.
- [40] Gustave Choquet. *Topology*. Academic Press, New York, 1966.

- [41] Gustave Choquet. *Lectures on analysis*. W.A. Benjamin, New York, 1969.
- [42] Daniel E. Cohen. *Combinatorial group theory: a topological approach*. Cambridge University Press, Cambridge; New York, 1989.
- [43] W.W. Comfort and S. Negrepointis. *The theory of ultrafilters*. Springer-Verlag, Berlin, New York, 1974.
- [44] W.W. Comfort and S. Negrepointis. *Continuous pseudometrics*. M. Dekker, New York, 1975.
- [45] W.W. Comfort and S. Negrepointis. *Chain conditions in topology*. Cambridge University Press, Cambridge, England; New York, 1982.
- [46] James P. Corbett. *Topological principles in cartography*. US Department of Commerce, Washington, D.C., 1980.
- [47] J.-M. Cordier. *Shape theory: categorical methods of approximation*. Halstead Press, Chichester, England; New York, 1989.
- [48] Jane Cronin. *Fixed points and topological degree in nonlinear analysis*. American Mathematical Society, Providence, R.I., 1964.
- [49] R.J. Daverman and R.B. Sher, editors. *Handbook of geometric topology*. Elsevier, Amsterdam; New York, 2002.
- [50] H. de Vries. *Compact spaces and compactifications: an algebraic approach*. Van Gorcum, Assen, 1962.
- [51] Tammo tom Dieck. *Topologie*. de Gruyter, Berlin, 2000.
- [52] Egbert Dierker. *Topological methods in Walrasian economics*. Springer-Verlag, Berlin; New York, 1974.
- [53] Jean Alexandre Dieudonne. *A history of algebraic and differential topology, 1900-1960*. Birkhauser, Boston, 1989.
- [54] Dikran N. Dikranjan. *Categorical structure of closure operators with applications to topology, algebra and discrete mathematics*. Kluwer Academic Publishers, Dordrecht, Boston, 1995.

- [55] Mircea V. Diudea and L. Jantschi. *Molecular topology*. Nova Science Publishers, Huntington, N.Y., 2001.
- [56] C.T.J. Dodson. *Category bundles and spacetime topology*. Kluwer Academic Publishers, Dordrecht, Boston, 1988.
- [57] C.T.J. Dodson. *A user's guide to algebraic topology*. Kluwer Academic Publishers, Dordrecht, Boston, 1997.
- [58] Albrecht Dold. *Lectures on algebraic topology*. Springer, Berlin, 1995.
- [59] James Dugundji. *Topology*. Allyn and Bacon, Boston, 1966.
- [60] Herbert Edelsbrunner. *Geometry and topology for mesh generation*. Cambridge University Press, Cambridge; New York, 2001.
- [61] Gerald A. Edgar. *Measure, topology and fractal geometry*. Springer-Verlag, New York, 1990.
- [62] R.E. Edwards. *Curves and topological questions*. Australian National University, Canberra, Australia, 1969.
- [63] Robert E. Edwards. *Functional analysis: theory and applications*. Holt, Rinehart and Winston, N.Y., 1965.
- [64] James Eels. *Singularities of smooth maps*. Gordon and Breach, New York, 1967.
- [65] Samuel Eilenberg and Norman Steenrod. *Foundations of algebraic topology*. Princeton University Press, Princeton, N.J., 1952.
- [66] Murray Eisenberg. *Topology*. Holt, Rinehart and Winston, New York, 1974.
- [67] Patrik Eklund. *Categorical fuzzy topology*. Abo Akademi, Abo, 1986.
- [68] Ryszard Engelking. *General topology*. PWN – Polish Scientific Publishers, Warsaw, 1977.
- [69] Ryszard Engelking. *Dimension theory*. North-Holland Publishing Co., Amsterdam; New York, 1978.
- [70] William W. Fairchild and Cassius Ionescu Tulceac. *Topology*. W.B. Saunders Company, Philadelphia, London, Toronto, 1971.

- [71] Erica Flapan. *When topology meets chemistry: a topological look at molecular chirality*. Cambridge University Press, Cambridge; New York, 2000.
- [72] Graham Flegg. *From geometry to topology*. Dover Publications, Mineola, N.Y., 2001.
- [73] D.H. Fremlin. *Consequences of Martin's Axioms*. Cambridge University Press, Cambridge; New York, 1984.
- [74] Robert Froman. *Rubber bands, baseballs and doughnuts; a book about topology. Illustrated by Harvey Weiss*. Crowell, New York, 1972.
- [75] David B. Gauld. *Differential topology: an introduction*. M. Dekker, New York, 1982.
- [76] *General Topology Front for the Mathematics ArXiv*, <http://front.math.ucdavis.edu/math.gn>, 1992–. Los Alamos National Laboratory e-Print archive.
- [77] Gerhard Gierz, K.H. Hofmann, K. Keimel, J.D. Lawson, M.W Mislove, and D.S. Scott. *A compendium of continuous lattices*. Springer-Verlag, Berlin, Heidelberg, New York, 1980.
- [78] Gerhard Gierz, K.H. Hofmann, K. Keimel, J.D. Lawson, M.W Mislove, and D.S. Scott. *Continuous lattices and domains*. Cambridge University Press, Cambridge, 2003.
- [79] Leonard Gillman and Meyer Jerison. *Rings of continuous functions*. Springer-Verlag, New York, 1976.
- [80] Robert Gilmore and Marc Lefranc. *The topology of chaos: Alice in stretch and squeezeland*. Wiley-Interscience, New York, 2002.
- [81] H. Brian Griffiths. *Surfaces*. Cambridge University Press, London; New York, 1976.
- [82] Jonathan L. Gross. *Topological graph theory*. Wiley, New York, 1987.
- [83] A. Grothendieck. *Topological vector spaces*. Gordon and Breach, New York, 1973.
- [84] Paul Halmos. *Naive set theory*. Van Nostrand Reinhold Company, New York, Cincinnati, 1960.
- [85] Felix Hausdorff. *Grundzuge der Mengenlehre*. Walter de Gruyter & Co., Berlin, 1927.

- [86] Horst Herrlich and Hans-E. Porst, editors. *Category theory at work*. Heldermann-Verlag, Berlin, 1991.
- [87] Edwin Hewitt and Kenneth A. Ross. *Abstract harmonic analysis I: structure of topological groups, integration theory, group representations*. Springer-Verlag, Berlin, 1963.
- [88] Edwin Hewitt and Kenneth A. Ross. *Abstract harmonic analysis II: structure and analysis for compact groups, analysis on locally compact abelian groups*. Springer-Verlag, Berlin, 1970.
- [89] Joachim Hilgert, Karl Heinrich Hofmann, and Jimmie D. Lawson. *Lie groups, convex cones and semigroups*. Clarendon Press, Oxford, 1997.
- [90] Peter John Hilton. *Homology theory: an introduction to algebraic topology*. Cambridge University Press, London, 1967.
- [91] Neil Hindman and Dona Strauss. *Algebra in the Stone-Cech compactification : theory and applications*. W. de Gruyter, New York, 1998.
- [92] John Gilbert Hocking and Gail S. Young. *Topology*. Addison-Wesley Publishing Co., Reading, Mass, 1961.
- [93] Karl H. Hofmann and Sidney A. Morris. *The Structure of compact groups: a primer for the student - a handbook for the expert*. W. de Gruyter, Berlin, New York, 1998.
- [94] Karl Heinrich Hofmann and Paul S. Mostert. *Elements of compact semigroups*. C.E. Merrill Books, Columbus, Ohio, 1966.
- [95] *Hopf Topology Archive*, <http://hopf.math.purdue.edu>, 1996–. Purdue University Hopf Archive of Topology preprints.
- [96] Juan Horvath. *Topological vector spaces and distributions*. Addison-Wesley, Reading, Mass., 1966.
- [97] Norman R. Howes. *Modern analysis and topology*. Springer-Verlag, New York, 1995.
- [98] S.T. Hu. *Introduction to general topology*. Holden-Day, San Francisco, 1966.
- [99] S.T. Hu. *Differentiable manifolds*. Holt, Rinehart and Winston, New York, 1969.

- [100] Sze-Tsen Hu. *Elements of general topology*. Holden-Day, San Francisco, 1964.
- [101] Sze-Tsen Hu. *Homology theory; a first course in algebraic topology*. Holden-Day, San Francisco, 1966.
- [102] Witold Hurewicz. *Dimension theory*. Princeton University Press, Princeton, N.J., 1941.
- [103] Taqdir Husain. *The open mapping and closed graph theorems in topological vector spaces*. Clarendon Press, Oxford, 1965.
- [104] Taqdir Husain. *Introduction to topological groups*. W.B. Saunders, Philadelphia, 1966.
- [105] Taqdir Husain. *Topology and maps*. Plenum Press, New York, 1977.
- [106] Miroslav Husek and Jan Van Mill. *Recent progress in general topology*. North-Holland, Amsterdam; New York, 1992.
- [107] J.R. Isbell. *Uniform spaces*. American Mathematical Society, Providence, R.I., 1964.
- [108] I.M. James. *General topology and homotopy theory*. Springer-Verlag, New York, 1984.
- [109] I.M. James. *Handbook of algebraic topology*. Elsevier, Amsterdam; New York, 1995.
- [110] I.M. James. *History of topology*. Elsevier, Amsterdam; New York, 1999.
- [111] I.M. James. *Topologies and uniformities*. Springer, London; New York, 1999.
- [112] Arthur Jones, Sidney A. Morris, and Kenneth R. Pearson. *Abstract algebra and famous impossibilities*. Springer-Verlag Publishers, New York, Berlin etc, 1991 & 1993.
- [113] V. Kannan. *Ordinal invariants in topology*. American mathematical society, Providence, R.I., 1981.
- [114] Christian Kassel. *Quantum groups*. Springer-Verlag, New York, 1995.
- [115] Louis H. Kauffman and Randy A. Baadhio. *Quantum topology*. World Scientific Publishers, Singapore; River Edge, 1993.
- [116] John L. Kelley. *General topology*. Springer-Verlag, New York, 1991.
- [117] S.M. Khaleelulla. *Counterexamples in topological vector spaces*. Springer-Verlag, Berlin ; New York, 1982.

- [118] Wan-hui Kim and Robert Tien-wen Chien. *Topological analysis and synthesis of communication networks*. Columbia University Press, New York, 1962.
- [119] Bruce R. King. *Applications of graph theory and topology in inorganic cluster and coordination chemistry*. CRC Press, Boca Raton, Florida, 1993.
- [120] T. Yung Kong and Azriel Rosenfeld. *Topological algorithms for digital image processing*. Elsevier, Amsterdam; New York, 1996.
- [121] Gottfried Köthe. *Topological vector spaces*. Springer-Verlag, Berlin ; New York, 1983.
- [122] Kenneth Kunen. *Set theory*. North-Holland, Amsterdam, 1980.
- [123] Kenneth Kunen and Jerry E. Vaughan, editors. *Handbook of set-theoretic topology*. North-Holland, Amsterdam, 1984.
- [124] Kazimierz Kuratowski. *Introduction to set theory and topology*. Pergamonn Press, New York, 1961.
- [125] John M. Lee. *Introduction to topological manifolds*. Springer, New York, 2000.
- [126] Seymour Lipschutz. *Schaum's outline of general topology*. McGraw Hill, 1968.
- [127] Ying-ming Liu and Mao-kang Luo. *Fuzzy topology*. World Scientific Publishers, River Edge, N.J., 1997.
- [128] Charles Livingston. *Knot theory*. The Mathematical association of America, 1993.
- [129] George McCarty. *Topology; an introduction with application to topological groups*. McGraw Hill, New York, 1967.
- [130] Robert A. McCoy and Ibulu Ntantu. *Topological properties of spaces of continuous functions*. Springer-Verlag, New York, Berlin, 1988.
- [131] Dusa McDuff and Dietmar Salamon. *Introduction to symplectic topology*. Oxford University Press, New York, 1998.
- [132] Richard E. Merrifield and Howard E. Simmons. *Topological methods in chemistry*. Wiley, New York, 1989.

- [133] Emil G. Milewski. *The topology problem solver: a complete solution guide to any textbook*. Research and Education Association, Piscataway, N.J., 1994.
- [134] M. Mimura and Hirosi Toda. *Topology of Lie groups*. American Mathematical Society, Providence, R.I., 1991.
- [135] Edward E. Moise. *Introductory problem courses in analysis and topology*. Springer-Verlag, New York, 1982.
- [136] Mikhail I. Monastyrskaei. *Topology of gauge fields and condensed matter*. Plenum Press, New York, 1993.
- [137] Deane Montgomery and Leo Zippin. *Topological transformation groups*. Interscience Publishers, New York, 1955.
- [138] Robert L. Moore. *Foundations of point set topology*. American Mathematical Society, Providence, R.I., 1962.
- [139] Giuseppe Morandi. *The role of topology in classical and quantum physics*. Springer-Verlag, Berlin, New York, 1992.
- [140] K. Morita and J. Nagata, editors. *Topics in general topology*. North Holland, Amsterdam, 1989.
- [141] Sidney A. Morris. *Pontryagin duality and the structure of locally compact abelian groups*. Cambridge University Press, Cambridge; New York, 1977.
- [142] Sidney A. Morris. Are finite topological spaces worthy of study. *Austral. Math. Soc. Gazette*, 11:31–32, 1984.
- [143] Sidney A. Morris. An elementary proof that the Hilbert cube is compact. *Amer. Math. Monthly*, 91:563–564, 1984.
- [144] Gregory L. Naber. *Topological methods in Euclidean spaces*. Cambridge University Press, Cambridge, New York, 1980.
- [145] Gregory L. Naber. *Topology, geometry and gauge fields: foundations*. Springer, New York, 1997.
- [146] Keio Nagami. *Dimension theory*. Academic Press, New York, 1970.

- [147] Jun-iti Nagata. *Modern dimension theory*. Interscience Publishers, New York, 1965.
- [148] Jun-iti Nagata. *Modern general topology*. North Holland Publishing Company, Amsterdam, 1985.
- [149] Mikio Nakahara. *Geometry, topology and physics*. A. Hilger, Bristol, England; New York, 1990.
- [150] H. Nakano. *Topology and linear topological spaces*. Maruzen Co., Tokyo, 1951.
- [151] Lawrence Narici and Edward Beckenstein. *Topological vector spaces*. M. Dekker, New York, 1985.
- [152] Charles Nash. *Topology and geometry for physicists*. Academic Press, London, New York, 1983.
- [153] M.H.A. Newman. *Elements of the topology of plane sets of points*. Greenwood Press, Westport, Conn., 1985.
- [154] A.L. Onishchik. *Topology of transitive transformation groups*. Johann Ambrosius Barth, Leipzig, 1994.
- [155] John C. Oxtoby. *Measure and category; a survey of the analogies between topological and measure spaces*. Springer-Verlag, New York, 1971.
- [156] A.R. Pears. *Dimension Theory of general spaces*. Cambridge University Press, Cambridge, New York, 1975.
- [157] Anthony L. Peressini. *Ordered topological vector spaces*. Harper and Row, New York, 1967.
- [158] C.G.C. Pitts. *Introduction to metric spaces*. Oliver and Boyd, Edinburgh, 1972.
- [159] Ian R. Porteous. *Topological geometry*. Cambridge University Press, Cambridge, England, New York, 1981.
- [160] Bodo von Querenburg. *Mengentheoretische Topologie*. Springer-Verlag, Berlin, 2001.
- [161] George M. reed. *Surveys in general topology*. Academic Press, New york, 1980.
- [162] G.M. Reed, A.W. Roscoe, and R.F. wachter. *Topology and category theory in computer science*. Oxford University Press, Oxford, England, 1991.

- [163] Renzo L. Ricca. *An introduction to the geometry and topology of fluid flows*. Kluwer Academic Publishers, Dordrecht; Boston, 2001.
- [164] A.P. Robertson and Wendy Robertson. *Topological vector spaces*. Cambridge University Press, Cambridge, England, 1973.
- [165] Joseph J. Rotman. *An introduction to algebraic topology*. Springer-Verlag, New York, 1988.
- [166] Mary Ellen Rudin. *Lectures on set theoretic topology*. American Mathematical Society, Providence, R.I., 1975.
- [167] Hans Sagan. *Space-filling curves*. Springer-Verlag, New York, 1994.
- [168] M. Signore and F. Melchiorri. *Topological defects in cosmology*. World Scientific Publishers, Singapore, 1998.
- [169] George E. Simmons. *Introduction to topology and modern analysis*. McGraw Hill, New York, 1963.
- [170] I.M. Singer. *Lecture notes on elementary topology and geometry*. Springer-Verlag, New York, 1967.
- [171] Christopher G. Small. *The statistical theory of shape*. Springer, New York, 1996.
- [172] Alexei Sossinsky. *Knots: mathematics with a twist*. Harvard University Press, 2002.
- [173] Edwin H. Spanier. *Algebraic topology*. Springer-Verlag, New York, 1966.
- [174] John R. Stallings. *Lectures on polyhedral topology*. Tata Institute of Fundamental research, Bombay, India, 1967.
- [175] Lynn Arthur Steen and J. Arthur Seebach Jr. *Counterexamples in topology*. Holt, Rinehart and Winston, New York, 1970.
- [176] N.E. Steenrod. *Reviews of papers in algebraic and differential topology, topological groups and homological algebra*. American Mathematical Society, Providence, R.I., 191968.
- [177] N.E. Steenrod. *The topology of fibre bundles*. Princeton University Press, Princeton, N.J., 1951.

- [178] John Stillwell. *Classical topology and combinatorial group topology*. Springer-Verlag, New York, 1995.
- [179] Wolfgang Thron. *Topological structures*. Holt, Rinehart and Winston, New York, 1966.
- [180] *Topology*, <http://www.elsevier.com/locate/top>, 1962–. A hard-copy refereed research journal in topology and geometry.
- [181] *Topology and its Applications*, <http://www.elsevier.nl/locate/topol>, 1971–. A hard-copy refereed research journal in topology.
- [182] *Topology Atlas*, <http://at.yorku.ca/topology/>, 1995–. Topology related resources including preprints, researchers, courses, employment and conferences.
- [183] *Topology Proceedings*, <http://topology.auburn.edu/tp/top2.htm>, 1977–. A hard-copy refereed research journal publishing papers in all areas of topology and its applications including from those presented at the Spring Topology and Dynamics Conference and the Summer Conference on General Topology and its Applications.
- [184] J. van Mill. *The infinite-dimensional topology of function spaces*. Elsevier, Amsterdam, New York, 2001.
- [185] Jan van Mill and George M. Reed. *Open problems in topology*. North-Holland, Amsterdam, 1990.
- [186] Steven Vickers. *Topology via logic*. Cambridge University Press, Cambridge, 1990.
- [187] A.V. Vologodskii. *Topology and physics of circular DNA*. CRC Press, Boca Raton, 1992.
- [188] Russell C. Walker. *The Stone-Cech compactification*. Springer-Verlag, Berlin; New York, 1974.
- [189] C.T.C. Wall. *A geometric introduction to topology*. Addison-Wesley, Reading, Mass., 1972.
- [190] A.D. Wallace. *Differential topology; first steps*. W.A. Benjamin, New York, 1968.
- [191] Evert Wattel. *The compactness operator in set theory and topology*. Mathematisch Centrum, Amsterdam, 1968.
- [192] Jeffrey R. Weeks. *The shape of space*. Marcel Dekker, New York, 2002.

- [193] Stuart G. Whittington, De Witt Sumners, and Timothy Lodge, editors. *Topology and geometry in polymer science*. Springer, New York, 1998.
- [194] Robin Wilson. *Four colors suffice: how the map problem was solved*. Princeton University Press, Princeton, N.J., 2003.

Index

- \aleph_0 , **176**
- accumulation point, **51**
- algebraic number, **180**
- analytic set, **125**
- arrow, 84
- axiom
 - least upper bound, **60**
- Baire Category Theorem, **133**
- Baire space, **134**
- ball
 - closed unit, 152
- Banach
 - Fixed Point Theorem, **131**
- Banach space, **128**
- basis, **36**
- bijection, **175**
- bijective, **22**
- bikompakt, 153
- Bolzano-Weierstrass Theorem, **122**
- bound
 - greatest lower, 60
 - lower, **60**
 - upper, 60
- bounded, **60**, 148
 - above, **60**
 - below, **60**
 - metric, **108**
 - metric space, **108**
- Brouwer Fixed Point Theorem, 94
- $C[0, 1]$, 47, 152
- \mathfrak{c} , 188
- c_0 , 110
- Cantor
 - Georg, 183
- card , **188**
- cardinal number, **188**
- cardinality, **176**
- category
 - first, **135**
 - second, **135**
- Cauchy sequence, **119**
- circle group, 170
- clopen
 - set, **18**
- closed
 - mapping, 151, **159**
 - set, **16**
 - unit ball, 152
- closure, **53**
- cluster point, **51**
- coarser topology, 91, **159**
- cofinite topology, **20**
- compact, **142**, **143**
 - space, **143**

- compactum, 169
- complete, **120**
- completely metrizable, **124**
- completion
 - of a metric space, **126**
- component, 95, **167**, 168
- connected, **61**
 - component, **167**
 - locally, **170**
 - manifold, 114
 - path, **92**
 - pathwise, **92**
- continuous, 84
- continuous mapping, **86**
- continuum, **168**
- contraction
 - mapping, **130**
- Contraction Mapping Theorem, **131**
- contradiction, 32
- converge, 115
- Converse of Heine-Borel Theorem, **148**
- convex
 - set, **135**
- countability
 - first axiom of, 111
 - second axiom of, 41
- countable bases, **111**
- countable closed topology, 26
- countable set, 176
- countably infinite, **176**
- covering
 - open, **143**
- cylinder, 166
- decreasing sequence, **121**
- dense, **54**
 - everywhere, **54**
 - nowhere, **133**
- denumerable, **176**
- diagonal, 157
- differentiable, **132**
- dimension
 - zero, 96
- disconnected, **62**, 92
 - totally, 95
- discrete
 - metric, **99**
 - space, **9**
 - topology, **9**
- distance, **98**
- distance between sets, 119
- element
 - greatest, **60**
 - least, **60**
- embedding
 - isometric, **126**
- empty union, 13
- equipotent, **175**
- equivalence relation, 83, 127, 175
- equivalent metric, **106**
- euclidean
 - locally, 114
- euclidean metric, **99**
- euclidean metric on \mathbb{R}^2 , 99
- euclidean topology, **30**
- euclidean topology on \mathbb{R}^n , 39

- everywhere dense, **54**
- F_σ -set, 34, 138
- f^{-1} , **23**
- final segment topology, 14
- finer topology, 91, **159**
- finite, **176**
- finite subcovering, **143**
- finite-closed topology, **20**
- first axiom of countability, 111
- first category, **135**
- first countable, 111
- fixed point, 94, **130**
- fixed point property, 94
- Fixed Point Theorem, 94
 - Banach, **131**
- function
 - bijjective, **22**
 - continuous, 84
 - injective, **22**
 - inverse, **22**
 - one-to-one, **22**
 - onto, **22**
 - surjective, **22**
- Fundamental Theorem of Algebra, **171**
- G_δ -set, 34, 138
- Generalized Heine-Borel Theorem, 149, **165**
- Georg Cantor, 183
- greatest element, **60**
- greatest lower bound, 60
- group
 - circle, 170
 - topological, 170
- group of homeomorphisms, 75
- Hausdorff space, 68, **107**, 157
- Heine-Borel Theorem, **148**
 - Converse, **148**
 - Generalized, 149
- homeomorphic, **69**
 - locally, 82
- homeomorphism, **69**
 - local, 82
- if and only if, 35
- image
 - inverse, **23**
- increasing sequence, **121**
- indiscrete
 - space, **9**
 - topology, **9**
- induced topological space, 105
- induced topology, **64**, 105
- infimum, 60
- infinite, **176**
 - countably, **176**
- initial segment topology, 14
- injective, **22**
- Int, 59, **133**
- interior, 59, **133**
- Intermediate Value Theorem, **93**
- intersection of topologies, 27
- interval, **78**
- inverse
 - function, **22**
 - image, **23**
- isolated point, **138**

- isometric, 111, **126**
 - embedding, **126**
- isometry, 111, **126**
- ℓ_1 , 110
- ℓ_2 , 110
- ℓ_∞ , 110
- least element, **60**
- Least Upper Bound Axiom, **60**
- limit point, **51**
- line
 - Sorgenfrey, 60, 145, 158
- local
 - homeomorphism, 82
- locally
 - compact, 166
 - connected, **170**
 - euclidean, 114
 - homeomorphic, 82
- lower bound, 60
- lower semicontinuous, 139
- manifold
 - connected, 114
 - topological, 114
 - topological with boundary, 114
- map
 - bijjective, **22**
 - injective, **22**
 - inverse, **22**
 - one-to-one, **22**
 - onto, **22**
 - surjective, **22**
- mapping
 - closed, 151, **159**
 - continuous, **86**
 - contraction, **130**
 - lower semicontinuous, 139
 - open, 137, 151, **159**
 - upper semicontinuous, 139
- mathematical proof, 8
- meager, **135**
- Mean Value Theorem, **132**
- metric, **98**
 - bounded, **108**
 - discrete, **99**
 - equivalent, **106**
 - euclidean, 99, **99**
 - space, **98**
- metric space
 - bounded, **108**
 - complete, **120**
 - totally bounded, **113**
- metrizable, **108**
 - completely, **124**
- monotonic sequence, **121**
- \mathbb{N} , **66**
- \mathbb{N} , 9
- n -sphere, 165
- neighbourhood, **56**
- norm, 102
- normal space, 111, 152
- normed vector space, 102
- nowhere dense, **133**
- number
 - algebraic, **180**

- cardinal, **188**
- transcendental, **180**
- object, **84**
- one-to-one, **22**
- one-to-one correspondence, **175**
- onto, **22**
- open
 - ball, **103**
 - covering, **143**
 - mapping, **137, 151, 159**
 - set, **15**
- open covering, **143**
- Open Mapping Theorem, **136**
- \mathbb{P} , **34, 66**
- $\mathcal{P}(S)$, **183**
- path, **92**
- path-connected, **92**
- pathwise connected, **92**
- peak point, **121**
- point, **51**
 - accumulation, **51**
 - cluster, **51**
 - fixed, **94, 130**
 - isolated, **138**
 - limit, **51**
 - neighbourhood of, **56**
 - peak, **121**
- Polish space, **125**
- power set, **183**
- product, **155**
 - space, **155**
 - topology, **155, 161**
- product of cardinal numbers, **193**
- product topology, **41**
- proof
 - by contradiction, **32**
 - if and only if, **35**
 - mathematical, **8**
- proper subset, **19**
- property
 - fixed point, **94**
 - separation, **28**
 - topological, **83**
- \mathbb{Q} , **33, 66**
- \mathbb{R} , **14, 30, 170**
- \mathbb{R}^2 , **39**
- \mathbb{R}^n , **39**
- reflexive, **71**
- regular, **158**
- regular space, **68**
- relation
 - equivalence, **83, 127, 175**
 - reflexive, **71**
 - symmetric, **71**
 - transitive, **71**
- relative topology, **64**
- \mathbb{S}^n , **165**
- \mathbb{S}^1 , **165**
- second axiom of countability, **41**
- second axion of countability, **158**
- second category, **135**
- semicontinuous
 - lower, **139**

- upper, 139
- separable, 58, **125**, 158
- separation property, 28
- sequence
 - Cauchy, **119**
 - convergent, 115
 - decreasing, **121**
 - increasing, **121**
 - monotonic, **121**
- set
 - F_σ , 34, 138
 - G_δ , 34, 138
 - analytic, **125**
 - clopen, **18**
 - closed, **16**
 - convex, **135**
 - countable, **176**
 - denumerable, **176**
 - finite, **176**
 - first category, **135**
 - infinite, **176**
 - meager, **135**
 - of continuous real-valued functions, 47
 - of integers, 33, **66**
 - of irrational numbers, 34, **66**
 - of natural numbers, 9, **66**
 - of positive integers, 9, **66**
 - of rational numbers, 33, **66**
 - open, **15**
 - power, **183**
 - second category, **135**
 - uncountable, **176**
- Sierpinski space, 26
- Sorgenfrey line, 60, 145
- Souslin space, **125**
- space
 - T_0 , 26
 - T_1 , 26, 158
 - T_2 , 68, **107**
 - T_3 , 68
 - T_4 , 111
 - Baire, **134**
 - Banach, **128**
 - bikompakt, 153
 - compact, **143**
 - complete metric, **120**
 - completely metrizable, **124**
 - connected, **61**
 - disconnected, **62**
 - discrete, **9**
 - Hausdorff, 68, **107**, 157
 - indiscrete, **9**
 - induced by a metric, 105
 - locally compact, 166
 - locally connected, **170**
 - metric, **98**
 - metrizable, **108**
 - normal, 111, 152
 - normed vector, 102
 - Polish, **125**
 - product, **155**
 - regular, 68, 158
 - separable, 58, **125**, 158
 - Sierpinski, 26
 - Souslin, **125**
 - topological, **8**

- totally disconnected, 95, 158
- subbasis, 48
- subcovering
 - finite, **143**
- subsequence, **121**
- subset
 - dense, **54**
 - everywhere dense, **54**
 - proper, 19
- subspace, **64**
- subspace topology, **64**
- sum of cardinal numbers, **191**
- suppose
 - proof by contradiction, 32
- supremum, 60
- surface, 166
- surjective, **22**
- symmetric, 71

- T_0 -space, 26
- T_1 -space, 26, 158
- T_2 -space, 68, **107**
- T_3 -space, 68
- T_4 -space, 111
- \mathbb{T} , 114, 170
- Theorem
 - Baire Category, **133**
 - Banach Fixed Point, **131**
 - Bolzano-Weierstrass, **122**
 - Brouwer Fixed Point, 94
 - Contraction Mapping, **131**
 - Converse of Heine-Borel, **148**
 - Fundamental Theorem of Algebra, **171**
 - Generalized Heine-Borel, 149, **165**
 - Heine-Borel, **148**
 - Mean Value, 132
 - Open Mapping, **136**
 - Tychonoff, **164**
 - Weierstrass Intermediate Value, **93**
- topological
 - manifold, 114
 - manifold with boundary, 114
- topological group, 170
 - of real numbers, 170
- topological property, 83
- topological space, **8**
- topology, **8**
 - coarser, 91, **159**
 - cofinite, **20**
 - countable closed, 26
 - discrete, **9**
 - euclidean, **30**
 - euclidean on \mathbb{R}^n , 39
 - final segment, 14
 - finer, 91, **159**
 - finite-closed, **20**
 - indiscrete, **9**
 - induced, **64**
 - induced by a metric, 105
 - initial segment, 14
 - intersection, 27
 - product, 41, **155**, 161
 - relative, **64**
 - subspace, **64**
 - usual, 66
- totally bounded

- metric space, **113**
- totally disconnected, 95
- totally disconnected space, 158
- transcendental number, **180**
- transitive, 71
- Tychonoff's Theorem, **164**

- uncountable set, **176**
- union
 - empty, 13
- unit ball, 152
- upper bound, 60
- upper semicontinuous, 139
- usual topology, 66

- vector space
 - normed, 102

- Weierstrass Intermediate Value Theorem, **93**

- \mathbb{Z} , 33, **66**
- 0-dimensional, 96
- zero-dimensional, 96